

Changes for the Better

MITSUBISHI CNC

Connection Manual

E70 Series



Introduction

This manual covers the items required for installing and connecting the MITSUBISHI CNC E70 Series. Read this manual thoroughly and understand the product's functions and performance before starting to use.

This manual is written on the assumption that all optional functions are added, but the actually delivered device may not have all functions.

The unit names, cable names and various specifications are subject to change without notice. Please confirm these before placing an order.





This manual notes a reference chapter as "Chapter: Section: Paragraph".

(Example) For "1.3.1 List of Units":

"System Configuration: List of Configuration: List of Units"

("1.3.1 List of Units" included in "1.3 List of Configuration" of "1 System Configuration")

CAUTION

-  For items described as "Restrictions" or "Usable State" in this manual, the instruction manual issued by the machine tool builder takes precedence over this manual.
-  Items that are not described in this manual must be interpreted as "not possible".
-  This manual is written on the assumption that all optional functions are added. Confirm the specifications issued by the machine tool builder before starting to use.
-  Refer to the Instruction Manual issued by each machine tool builder for details on each machine tool.
-  Some screens and functions may differ depending on each NC system (or version), and some functions may not be possible. Please confirm the specifications before starting to use.

The numerical control unit is configured of the control unit, display unit, operation board (keyboard unit, operation panel I/O unit), servo drive unit, spindle drive unit, power supply unit + driver, servomotor, spindle motor, etc.

In this manual, the following items are generically called "controller".

- Control unit
- Display unit
- operation board (keyboard unit, operation panel I/O unit)
- Numerical control unit peripheral devices (input/output unit, safety unit)

In this manual, the following items are generically called "drive unit".

- Servo drive unit
- Spindle drive unit
- Power supply unit + driver

In this manual, the following items are generically called "motor".

- Servo motor
- Spindle motor

Refer to the following documents.

M700V/M70V/E70 Series PLC Interface Manual IB-1500920

MDS-DM2 Series Specifications Manual IB-1501136

MDS-DM2 Series Instruction Manual IB-1501139

MDS-DJ Series Specifications Manual IB-1501130



MDS-DJ Series Instruction Manual IB-1501133

Safety Handbook (Original Instructions) IB-1501025

Precautions for Safety





Always read this manual and enclosed documents before installation, operation, maintenance and inspection to ensure correct usage. Thoroughly understand the basics, safety information and precautions of the devices before using.

This manual classifies the safety precautions into "DANGER", "WARNING" and "CAUTION".











 DANGER When the user could be subject to imminent fatalities or serious injuries if handling is mistaken.
 WARNING When the user could be subject to fatalities or serious injuries if handling is mistaken.
 CAUTION When the user could be subject to injuries or the property could be damaged if handling is mistaken.

Note that the items under "  CAUTION" could lead to serious consequences as well depending on the situation. All the items are important and must always be observed.

The following signs indicate prohibition and compulsory.

	This sign indicates prohibited behavior (must not do). For example,  indicates "Keep fire away".
	This sign indicated a thing that is compulsory (must do). For example,  indicates "it must be grounded".

The meaning of each pictorial sign is as follows.

 CAUTION	 CAUTION rotated object	 CAUTION HOT	 Danger Electric shock risk	 Danger explosive
 Prohibited	 Disassembly is prohibited	 KEEP FIRE AWAY	 General instruction	 Earth ground

For Safe Use









Mitsubishi CNC is designed and manufactured solely for applications to machine tools.

Do not use this product in any applications other than those specified as above, especially those which are substantially influential on the public interest or which are expected to have significant influence on human lives or properties.

We will review the acceptability of the abovementioned applications, if the customer agrees not to require a specific quality for a specific application. Please contact us for consultation.

1. Items related to prevention of electric shocks



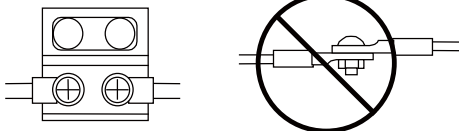

WARNING

-  Do not open or remove the front cover while the power is ON or during operation. The high voltage terminals and charged sections will be exposed, and this could result in electric shocks.
-  Do not remove the front cover even when the power is OFF, except for the wiring works or periodic inspections. The inside of the controller and drive unit are charged, and this could result in electric shocks.
- Always wait at least 15 minutes after turning the power OFF. Then, check the voltage with a tester, etc., before wiring works, inspections or connecting with peripheral devices. Failure to observe this could result in electric shocks.
-  Earth ground the controller, drive unit and motor according to the local laws. (In Japan, ground the 200V Series input products with Class C or higher protective grounding and the 400V Series input with Class D or higher protective grounding.)
-  All wiring works, maintenance and inspections must be carried out by a qualified technician. Failure to observe this could result in electric shocks. Contact your nearby Service Center or Service Station for replacing parts and servicing.
-  Wire the controller, drive unit and motor after installation. Failure to observe this could result in electric shocks.
-  Do not operate the switches with wet hands. Failure to observe this could result in electric shocks.
-  Do not damage, apply excessive stress, place heavy things on or sandwich the cables. Failure to observe this could result in electric shocks.
-  Insulate the power lead using a fixed terminal block. Failure to observe this could result in electric shocks.



2. Items related to prevention of fire

CAUTION

-  Install the controller, drive unit, motor and regenerative resistor on non-combustible material. Installation directly on or near combustible materials could result in fires.
-  If any malfunction in the unit is observed, shut off the power at the unit's power supply side. Continuous flow of large current could result in fires.
-  Install an appropriate no fuse breaker (NFB) and contactor (MC) on the power input section of the drive unit and configure the sequence that shuts the power off upon drive unit's emergency stop or alarm.
-  When a breaker is shared for multiple power supply units, the breaker may not function upon short-circuit failure in a small capacity unit. Do not share a breaker for multiple units as this is dangerous.
-  Incorrect wiring and connections could cause the devices to damage or burn.

3. Items related to prevention of bodily injury or property damage

DANGER



When transporting or installing a built-in IPM spindle or linear servomotor, be careful so that your hand or property will not be trapped in the motors or other metal objects. Also keep the devices with low magnetic tolerance away from the product.

CAUTION



Do not apply voltages to the connectors or terminals other than voltages indicated in the connection manual for the controller or specifications manual for the drive unit. Failure to observe this could cause bursting, damage, etc.



Incorrect connections could cause the devices to rupture or damage, etc. Always connect the cables to the indicated connectors or terminals.



Incorrect polarity (+ -) could cause the devices to rupture or damage, etc.



Persons wearing medical devices, such as pacemakers, must stay away from this unit. The electromagnetic waves could adversely affect the medical devices.



Fins on the rear of the unit, regenerative resistor and motor, etc., will be hot during operation and for a while after the power has been turned OFF. Do not touch or place the parts and cables, etc. close to these sections. Failure to observe this could result in burns.























Do not enter the machine's movable range during automatic operation. Keep your hands, feet or face away from the spindle during rotation.

4. General precautions









Always follow the precautions below. Incorrect handling could result in faults, injuries or electric shocks, etc.

(1) Transportation and installation

CAUTION

-  Correctly transport the products according to the mass.
-  Use motor' s suspension bolts to transport the motor itself. Do not use it to transport the motor after installation onto the machine.
-  Do not stack the products exceeding the indicated limit.
-  Do not hold the cables, shaft or detector when transporting the motor.
-  Do not transport the controller or drive unit by suspending or holding the connected wires or cables.
-  Do not hold the front cover when transporting the unit, or the front cover could come off, causing the unit to drop.
-  Install on a non-combustible place where the unit' s or motor' s mass can be withstood according to the instruction manual.
-  The motor does not have a complete water-proof (oil-proof) structure. Do not allow oil or water to contact or enter the motor. Prevent the cutting chips from being accumulated on the motor as they easily soak up oil.
-  When installing the motor facing upwards, take measures on the machine side so that gear oil, etc., will not enter the motor shaft.
-  Do not remove the detector from the motor. (The detector installation screw is treated with sealing.)
-  Do not allow foreign matters, especially, conductive foreign matters such as screws or metal chips, or combustible foreign matters such as oil, to enter the controller, drive unit or motor. Failure to observe this could result in rupture or damage.
-  Do not get on the product or place heavy objects on it.
-  Provide prescribed distance between the controller/drive unit and inner surface of the control panel/other devices.
-  Do not install or operate the controller, drive unit or motor that is damaged or has missing parts.
-  Take care not to cut hands, etc. with the heat radiating fins or metal edges.
-  Do not block the intake/outtake ports of the motor with the cooling fan.
-  Install the controller' s display section and operation board section on the spot where cutting oil will not reach.
-  The controller, drive unit and motor are precision devices, so do not drop or apply thumping vibration and strong impacts on them.
-  Hard disk unit is a precision device, so do not drop or apply strong impacts on it.
-  Store and use the units according to the environment conditions indicated in each specifications manual.
-  Securely fix the motor to the machine. The motor could come off during operation if insecurely fixed.

 CAUTION

-  Always install the motor with reduction gear in the designated direction. Failure to observe this could result in oil leaks.
-  Always install a cover, etc., over the shaft so that the rotary section of the motor cannot be touched during motor rotation.
-  When installing a coupling to the servomotor shaft end, do not apply impacts by hammering, etc. The detector could be damaged.
-  Use a flexible coupling when connecting with a ball screw, etc., and keep the shaft core deviation smaller than the tolerable radial load of the shaft.
-  Do not use a rigid coupling as an excessive bending load will be applied on the shaft and could cause the shaft to break.
-  Do not apply a load exceeding the tolerable level onto the motor shaft. The shaft or bearing could be damaged.
-  Before using this product after a long period of storage, please contact the Mitsubishi Service Station or Service Center.
-  Following the UN recommendations, battery units and batteries should be transported based on the international regulations such as those determined by International Civil Aviation Organization (ICAO), International Air Transport Association (IATA), International Maritime Organization (IMO) and U.S. Department of Transportation (DOT).

(2) Items related to wiring

⚠ CAUTION

- ⚠ Correctly wire this product. Failure to observe this could result in motor runaway, etc.
- ⚠ Do not install a phase advancing capacitor, surge absorber or radio noise filter on the output side of the drive unit.
- ⚠ Correctly connect the output side (terminal U, V, W). The motor will not run properly if incorrectly connected.
- ⚠ Always install an AC reactor per each power supply unit.
- ⚠ Always install an appropriate breaker per each power supply unit. A breaker cannot be shared for multiple power supply units.
- ⚠ Do not directly connect a commercial power supply to the motor. Failure to observe this could result in faults.
- ❗ When using an inductive load such as relays, always connect a diode in parallel to the load as a noise countermeasure.
- ❗ When using a capacitive load such as a lamp, always connect a protective resistor serially to the load to suppress rush currents.
- ⚠ Do not mistake the direction of the surge absorption diode to be installed on the DC relay for the control output signal. If mistaken, the signal will not be output due to fault in the drive unit, and consequently the protective circuit, such as emergency stop, could be disabled.

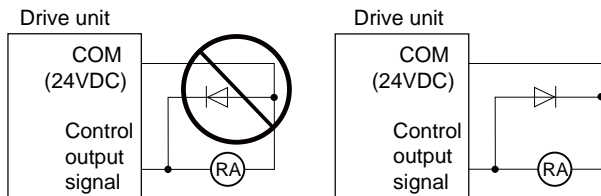

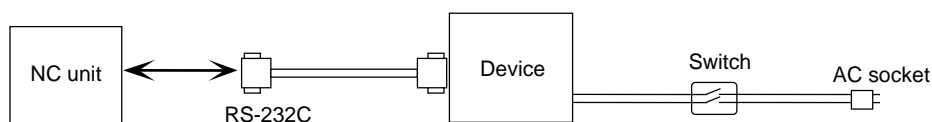

- ⊘ Do not connect or disconnect the cables between units while the power is ON.
- ⚠ Do not connect or disconnect the PCBs while the power is ON.
- ⚠ Do not pull the cables when connecting/disconnecting them.
- ⚠ Securely tighten the cable connector fixing screw or fixing mechanism. The motor could come off during operation if insecurely fixed.
- ⚡ Always treat the shield cables indicated in the Connection Manual with grounding measures such as cable clamps.
- ⚠ Separate the signal wire from the drive line or power line when wiring.
- ⚠ Use wires and cables whose wire diameter, heat resistance level and bending capacity are compatible with the system.
- ⚡ Ground the device according to the requirements of the country where the device is to be used.
- ⚠ Wire the heat radiating fins and wires so that they do not contact.
- ⚠ When using the RS-232C device as a peripheral device, caution must be paid for connector connection/disconnection. Always use a double-OFF type AC power supply switch on the device side, and connect/disconnect the connector with the AC power supply on the device side OFF.

















(3) Adjustments

CAUTION

-  Check and adjust programs and each parameter before starting operation. Failure to observe this could result in unpredictable operations depending on the machine.
-  Do not make drastic adjustments or changes as the operation could become unstable.

(4) Usage

CAUTION

-  Install an external emergency stop circuit so that the operation can be stopped and the power turns OFF immediately when unforeseen situation occurs. A contactor, etc., is required in addition to the shutoff function mounted in the controller.
-  Turn OFF the power immediately if any smoke, abnormal noise or odor is generated from the controller, drive unit or motor.
-  Only a qualified technician may disassemble or repair this product.
-  Do not alter.
-  Use a noise filter, etc. to reduce the effect of electromagnetic disturbances in the case where electromagnetic disturbances could adversely affect the electronic devices used near the drive unit.
-  Use the drive unit, motor and each regenerative resistor with the designated combination. Failure to observe this could result in fires or faults.
-  The combination of the motor and drive unit that can be used is determined. Be sure to check the models of motor and drive unit before test operation.
-  The brakes (electromagnetic brakes) mounted in the servomotor are used for the purpose of holding, and must not be used for normal braking. Also, do not run the motor with the motor brake applied. Motor brake is used for the purpose of holding.
-  For the system running via a timing belt, install a brake on the machine side so that safety can be ensured.
-  Be sure to confirm SERVO OFF (or READY OFF) when applying the electromagnetic brake. Also, be sure to confirm SERVO ON prior to releasing the brake.
-  When using the DC OFF type electromagnetic brake, be sure to install a surge absorber on the brake terminal.
-  Do not connect or disconnect the cannon plug while the electromagnetic brake's power is ON. The cannon plug pins could be damaged by sparks.
-  After changing programs/parameters, or after maintenance/inspection, always carry out a test operation before starting actual operation.
-  Use the power that are complied with the power specification conditions (input voltage, input frequency, tolerable instantaneous power failure time) indicated in each specifications manual.
-  When making detector cables, do not mistake connection. Failure to observe this could result in malfunction, runaway or fire.

(5) Troubleshooting

⚠ CAUTION

⚠ Use a motor with electromagnetic brakes or establish an external brake mechanism for the purpose of holding; this serves as countermeasures for possible hazardous situation caused by power failure or product fault.

⚠ Use a double circuit structure for the electromagnetic brake's operation circuit so that the brakes will activate even when the external emergency stop signal is issued.

⚠ The machine could suddenly restart when the power is restored after an instantaneous power failure, so stay away from the machine. (Design the machine so that the operator safety can be ensured even if the machine restarts.)





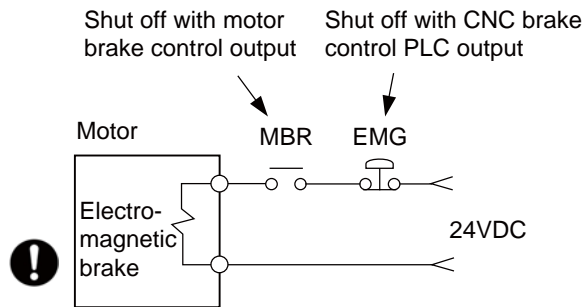

⚠ To secure the absolute position, do not shut off the servo drive unit's control power supply when its battery voltage drops (warning 9F) in the servo drive unit side.

! If the battery voltage drop warning alarm occurs in the controller side, make sure to back up the machining programs, tool data and parameters, etc. with the input/output device before replacing the battery. Depending on the level of voltage drop, memory loss could have happened. In that case, reload all the data backed up before the alarm occurrence.





(6) Maintenance, inspection and part replacement

 CAUTION

-  Periodically back up the programs, tool data and parameters to avoid potential data loss. Also, back up those data before maintenance and inspections.
-  When replacing the battery on the controller side, the machining programs, tool data and parameters should be backed up with the input/output device beforehand. In case the memory is damaged in replacing the batteries, reload all the data backed up before replacing the battery.
-  The electrolytic capacitor's capacity will drop due to deterioration. To prevent secondary damage due to capacitor's faults, Mitsubishi recommends the electrolytic capacitor to be replaced approx. every five years even when used in a normal environment. Contact the Service Center or Service Station for replacements.
-  Do not perform a megger test (insulation resistance measurement) during inspection.
-  Do not replace parts or devices while the power is ON.
-  Do not short-circuit, charge, overheat, incinerate or disassemble the battery.
-  There may be a unit filled with substitute Freon in the heat radiating fins of the 37kW or smaller unit. Be careful not to break the heat radiating fins during maintenance or replacement.

(7) Disposal

 CAUTION

-  Take the batteries and backlights for LCD, etc., off from the controller, drive unit and motor, and dispose of them as general industrial wastes.
-  Do not alter or disassemble controller, drive unit, or motor.
-  Collect and dispose of the spent batteries and the backlights for LCD according to the local laws.

(8) General precautions

To explain the details, drawings given in the instruction manual, etc., may show the unit with the cover or safety partition removed. When operating the product, always place the cover or partitions back to their original position, and operate as indicated in the instruction manual, etc.

Treatment of waste

The following two laws will apply when disposing of this product. Considerations must be made to each law. The following laws are in effect in Japan. Thus, when using this product overseas, the local laws will have a priority. If necessary, indicate or notify these laws to the final user of the product.

- (1) Requirements for "Law for Promotion of Effective Utilization of Resources"
 - (a) Recycle as much of this product as possible when finished with use.
 - (b) When recycling, often parts are sorted into steel scraps and electric parts, etc., and sold to scrap contractors. Mitsubishi recommends sorting the product and selling the members to appropriate contractors.

- (2) Requirements for "Law for Treatment of Waste and Cleaning"
 - (a) Mitsubishi recommends recycling and selling the product when no longer needed according to item (1) above. The user should make an effort to reduce waste in this manner.
 - (b) When disposing a product that cannot be resold, it shall be treated as a waste product.
 - (c) The treatment of industrial waste must be commissioned to a licensed industrial waste treatment contractor, and appropriate measures, including a manifest control, must be taken.
 - (d) Batteries correspond to "primary batteries", and must be disposed of according to local disposal laws.

Disposal



(Note) This symbol mark is for EU countries only.
This symbol mark is according to the directive 2006/66/EC Article 20 Information for end-users and Annex II.

Your MITSUBISHI ELECTRIC product is designed and manufactured with high quality materials and components which can be recycled and/or reused.

This symbol means that batteries and accumulators, at their end-of-life, should be disposed of separately from your household waste.

If a chemical symbol is printed beneath the symbol shown above, this chemical symbol means that the battery or accumulator contains a heavy metal at a certain concentration. This will be indicated as follows:

Hg: mercury (0,0005%), Cd: cadmium (0,002%), Pb: lead (0,004%)

In the European Union there are separate collection systems for used batteries and accumulators. Please, dispose of batteries and accumulators correctly at your local community waste collection/ recycling centre.

Please, help us to conserve the environment we live in!

Trademarks

MELDAS, MELSEC, EZSocket, EZMotion, iQ Platform, MELSOFT, GOT, CC-Link, CC-Link/LT and CC-Link IE are either trademarks or registered trademarks of Mitsubishi Electric Corporation in Japan and/or other countries.

Ethernet is a registered trademark of Xerox Corporation in the United States and/or other countries.

Microsoft® and Windows® are either trademarks or registered trademarks of Microsoft Corporation in the United States and/or other countries.

CompactFlash and CF are either trademarks or registered trademarks of SanDisk Corporation in the United States and/or other countries.

UNIX is a registered trademark of The Open Group in the United States and/or other countries.

Intel® and Pentium® are either trademarks or registered trademarks of Intel Corporation in the United States and/or other countries.

Other company and product names that appear in this manual are trademarks or registered trademarks of the respective companies.

本製品の取扱いについて

(日本語/Japanese)

本製品は工業用(クラス A)電磁環境適合機器です。販売者あるいは使用者はこの点に注意し、住商業環境以外での使用をお願いいたします。

Handling of our product

(English)

This is a class A product. In a domestic environment this product may cause radio interference in which case the user may be required to take adequate measures.

본 제품의 취급에 대해서

(한국어/Korean)

이 기기는 업무용(A급) 전자파적합기기로서 판매자 또는 사용자는 이 점을 주의하시기 바라며 가정외의 지역에서 사용하는 것을 목적으로 합니다.

Contents

1 System Configuration	1
1.1 System Basic Configuration Drawing	2
1.2 General Connection Diagram	3
1.3 List of Configuration	5
1.3.1 List of Units	5
1.3.2 Durable Parts	6
1.3.3 Replacements	6
1.3.4 List of Cables	7
2 General Specifications	9
2.1 Environment Conditions	10
2.2 Control Unit	11
2.3 Display Unit	21
2.4 Keyboard Unit	22
2.5 Operation Panel I/O Unit	24
2.6 Remote I/O Unit	36
2.7 External Power Supply Unit	43
2.8 Manual Pulse Generator	45
2.9 Synchronous Feed Encoder	47
2.10 MITSUBISHI CNC Machine Operation Panel	48
2.10.1 MITSUBISHI CNC Machine Operation Panel A	48
2.10.2 MITSUBISHI CNC Machine Operation Panel B	55
2.11 Exclusive CF Cards for MITSUBISHI CNC	59
2.11.1 Precautions for Use of Commercially Available CF Cards	59
3 Installation	61
3.1 Heat Radiation Countermeasures	62
3.2 Noise Countermeasures	65
3.2.1 Connection of FG (Frame Ground)	65
3.2.2 Shield Clamping of Cables	66
3.2.3 Connecting Spark Killers	66
3.3 Unit Installation	67
3.3.1 Display Unit	67
3.3.2 Keyboard Unit	68
3.3.3 Operation Panel I/O Unit	68
3.3.4 Control Unit Battery	69
4 Connection	71
4.1 Precautions for Wiring	72
4.1.1 Precautions when Connecting/Disconnecting Cables	72
4.1.2 Precautions for Using Optical Communication Cable	75
4.1.2.1 Optical Communication Cable Outline and Parts	75
4.1.2.2 Precautions for Handling Optical Communication Cable	75
4.1.2.3 Precautions for Laying Optical Communication Cable	76
4.1.3 Precautions for Connecting 24V Power Supply	76
4.2 Connection of Control Unit	77
4.2.1 Control Unit Connection System Drawing	77
4.2.2 Connecting with Power Supply	78
4.2.3 Connecting with Emergency Stop Signal	79
4.2.4 Connecting with Operation Panel I/O Unit	81
4.2.5 Connecting with Drive Unit	82
4.2.5.1 Connecting with MDS-DM2 Series	83
4.2.5.2 Connecting with MDS-DJ Series	84
4.2.6 Connecting with RS-232C Device	85
4.2.7 Connecting with Skip Signal (Sensor)	87
4.2.8 Connecting with Synchronous Feed Encoder/ Manual Pulse Generator	89
4.2.8.1 Handle Numbers	89
4.2.9 Connecting with Safety Observing I/O Device	90

4.3 Connection of Operation Panel I/O Unit.....	91
4.3.1 Operation Panel I/O Unit Connection System Drawing	91
4.3.2 Connecting with Keyboard Unit.....	92
4.3.3 Connecting with Manual Pulse Generator (MPG).....	93
4.3.3.1 Handle Numbers.....	94
4.3.4 Connecting with Machine Operation Panel.....	94
4.3.4.1 Wiring for 24V Common Input.....	95
4.3.4.2 Wiring for 0V Common Input.....	95
4.3.4.3 Wiring for Source Type Output (FCU7-DX621/DX711/DX721/DX731)	96
4.3.4.4 Outline of Analog Signal Output Circuit	97
4.4 Connection of Remote I/O Unit	98
4.4.1 Connection and Station No. Setting on Remote I/O Unit	98
4.4.2 Station No. Setting when Using Multiple Remote I/O Units	100
4.4.3 Connecting FCUA-DX101/141 Unit with Machine Control Signal.....	104
4.4.4 Connecting FCUA-DX141 Unit with Analog Input/Output Signal	106
4.4.5 Connecting FCUA-DX111 Unit with Machine Control Signal.....	107
4.4.6 Connecting FCUA-DX121 Unit with Machine Control Signal.....	109
4.5 Connection of MITSUBISHI CNC Machine Operation Panel.....	111
Appendix 1 Cable	115
Appendix 1.1 Cable Wire and Assembly.....	117
Appendix 1.2 CNP2E-1 Cable.....	119
Appendix 1.3 CNP3EZ-2P/CNP3EZ-3P Cable	120
Appendix 1.4 CNV22J-K1P / CNV22J-K2P Cable	121
Appendix 1.5 CNV2E-8P/CNV2E-9P Cable.....	122
Appendix 1.6 CNV2E-HP Cable.....	123
Appendix 1.7 CNV2E-K1P / CNV2E-K2P Cable.....	124
Appendix 1.8 DG21 Cable	125
Appendix 1.9 DG22 Cable	126
Appendix 1.10 DG23 Cable	127
Appendix 1.11 DG24 Cable	128
Appendix 1.12 DG25 Cable	129
Appendix 1.13 F023/F024 Cable	130
Appendix 1.14 F034/F035 Cable	131
Appendix 1.15 F070 Cable.....	132
Appendix 1.16 F110 Cable.....	133
Appendix 1.17 F120 Cable.....	134
Appendix 1.18 F170 Cable.....	135
Appendix 1.19 F221 Cable.....	136
Appendix 1.20 F320/F321 Cable	137
Appendix 1.21 F351 Cable.....	138
Appendix 1.22 FCUA-R030 Cable	139
Appendix 1.23 FCUA-R031 Cable	140
Appendix 1.24 FCUA-R050/R054 Cable.....	141
Appendix 1.25 FCUA-R211 Cable	142
Appendix 1.26 FCUA-R300/FCUA-R301 Cable.....	143
Appendix 1.27 G011 Cable	145
Appendix 1.28 G023/G024 Cable	146
Appendix 1.29 G071 Cable	147
Appendix 1.30 G300 Cable	148
Appendix 1.31 G301 Cable	149
Appendix 1.32 G380 Cable	150
Appendix 1.33 G395 Cable	151
Appendix 1.34 G396 Cable	152
Appendix 1.35 G460 Cable	153
Appendix 1.36 MR-BKS1CBL-A1-H / MR-BKS1CBL-A2-H Cable	154
Appendix 1.37 MR-PWS1CBL-A1-H / MR-PWS1CBL-A2-H Cable	155
Appendix 1.38 R-TM Terminator Connector	156
Appendix 1.39 SH21 Cable.....	157
Appendix 1.40 SH41 Cable.....	158
Appendix 1.41 List of Cable Connector Sets	159

Appendix 2 EMC Installation Guidelines	161
Appendix 2.1 Introduction	162
Appendix 2.2 EMC Directives	162
Appendix 2.3 EMC Measures	163
Appendix 2.4 Panel Structure	163
Appendix 2.4.1 Measures for Control Panel Body	163
Appendix 2.4.2 Measures for Door	164
Appendix 2.4.3 Measures for Power Supply	164
Appendix 2.5 Measures for Wiring in Panel	165
Appendix 2.5.1 Precautions for Wiring in Panel	165
Appendix 2.5.2 Shield Treatment of Cables	166
Appendix 2.6 EMC Countermeasure Parts	168
Appendix 2.6.1 Shield Clamp Fitting	168
Appendix 2.6.2 Ferrite Core	169
Appendix 2.6.3 Surge Absorber	170
Appendix 2.6.4 Selection of Stabilized Power Supply	172
Appendix 3 Restrictions for Lithium Batteries	173
Appendix 3.1 Restriction for Packing	174
Appendix 3.1.1 Target Products	175
Appendix 3.1.2 Handling by User	176
Appendix 3.1.3 Reference	177
Appendix 3.2 Products information data sheet (ER battery)	178
Appendix 3.3 Issuing Domestic Law of the United States for Primary Lithium Battery Transportation....	180
Appendix 3.3.1 Outline of Regulation	180
Appendix 3.3.2 Target Products	180
Appendix 3.3.3 Handling by User	180
Appendix 3.3.4 Reference	180
Appendix 3.4 Restriction related to EU Battery Directive	181
Appendix 3.4.1 Important Notes	181
Appendix 3.4.2 Information for end-user	181
Appendix 4 Precautions for Compliance to UL/c-UL Standards	183



System Configuration

1.1 System Basic Configuration Drawing

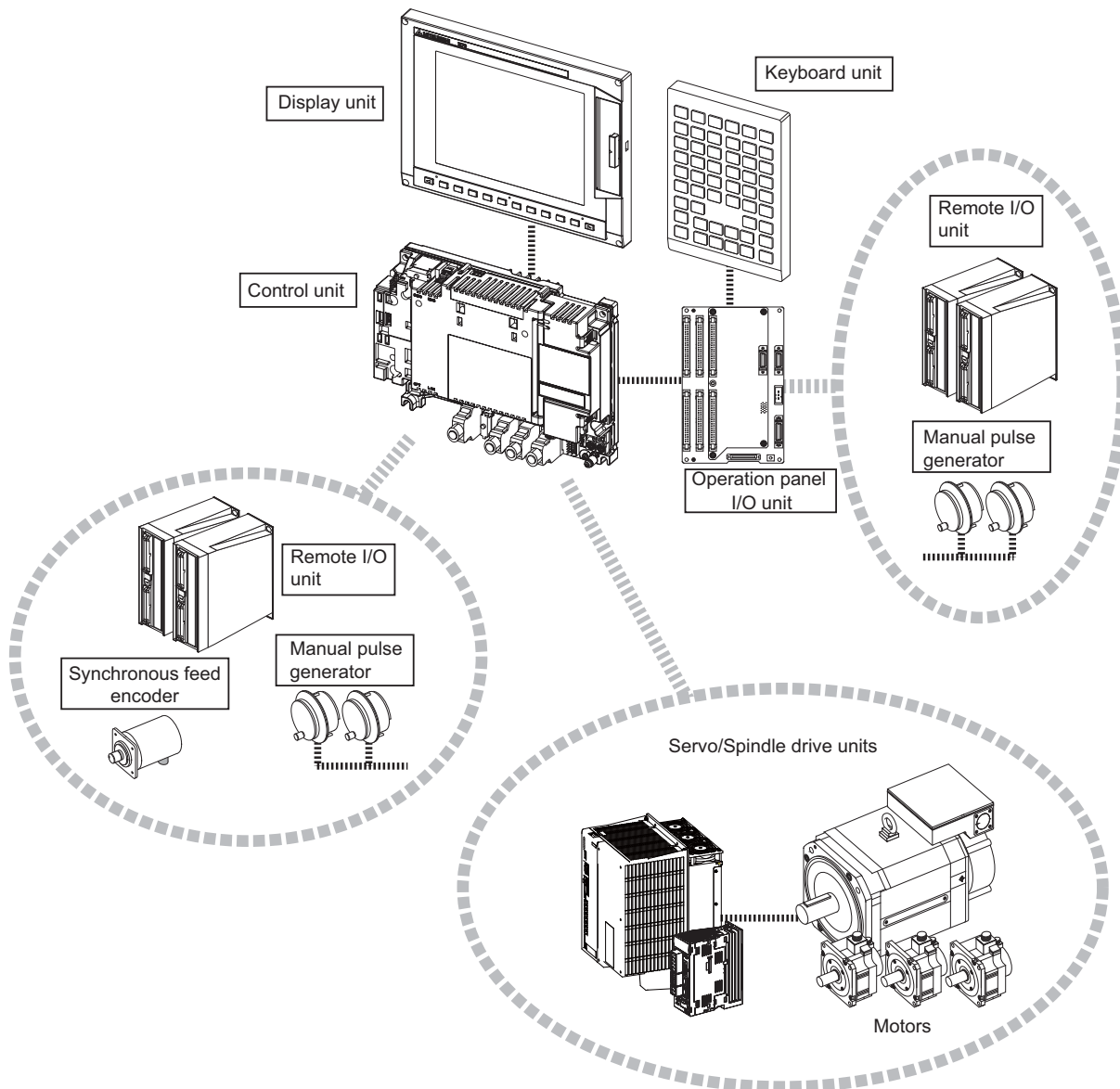

(Note 1) Control unit is mounted on the back side of the display unit.

(Note 2) Operation panel I/O unit is mounted on the back side of the keyboard unit.

(Note 3) For the drive unit configuration, refer to the Instruction Manual of the drive unit you use.

1.2 General Connection Diagram

 Dotted lines indicate the sections prepared by the machine tool builder.

The name with brackets < > indicates the cable for the unit.

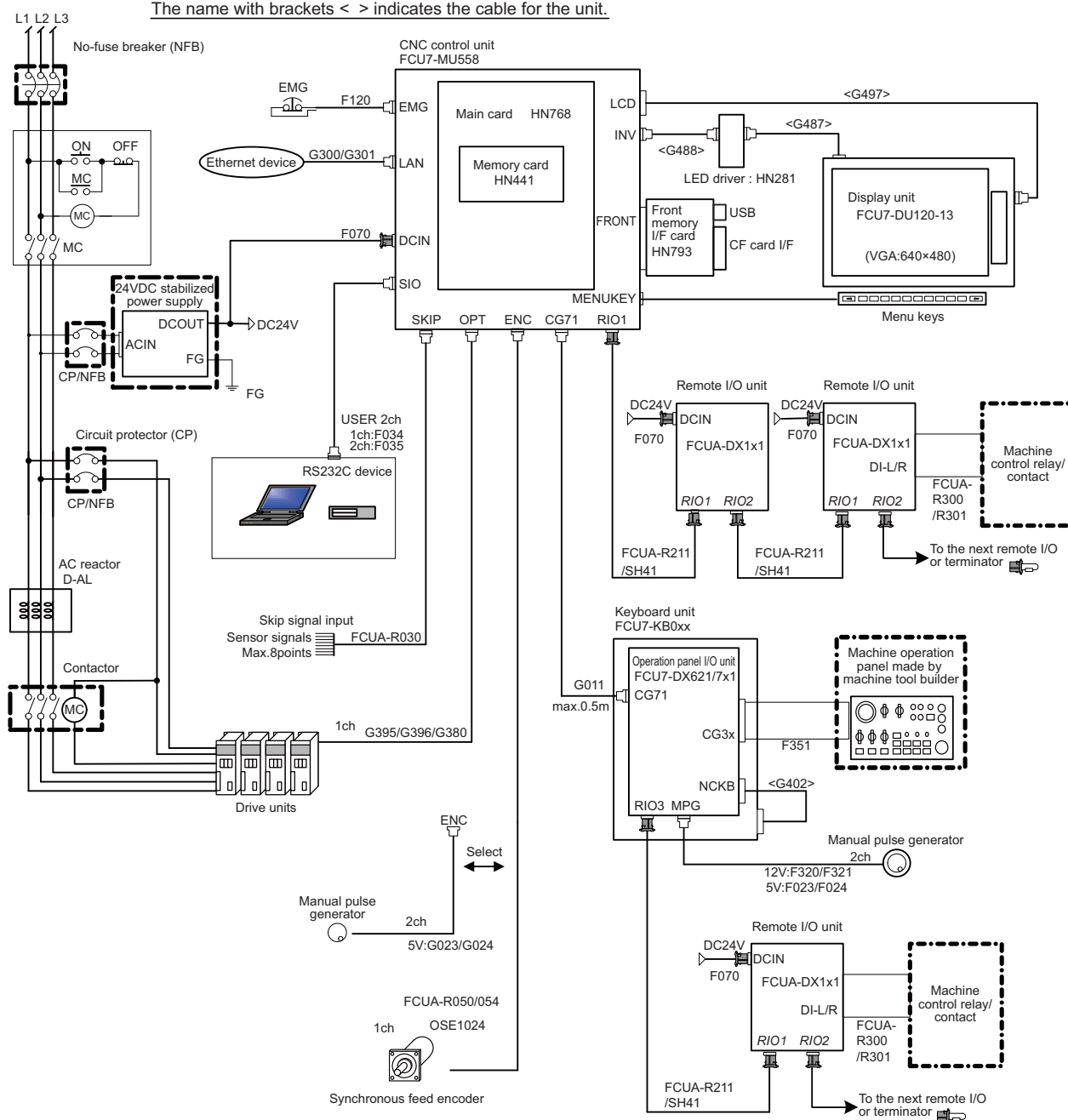

(Note 1) For information on how to connect the drive unit, refer to the drive unit's manual.

(Note 2) For a connection of the MITSUBISHI CNC Machine Operation Panel, refer to "Connection: Connection of MITSUBISHI CNC Machine Operation Panel" to be described.

[Analog Spindle Configuration]

 Dotted lines indicate the sections prepared by the machine tool builder.

The name with brackets < > indicates the cable for the unit.

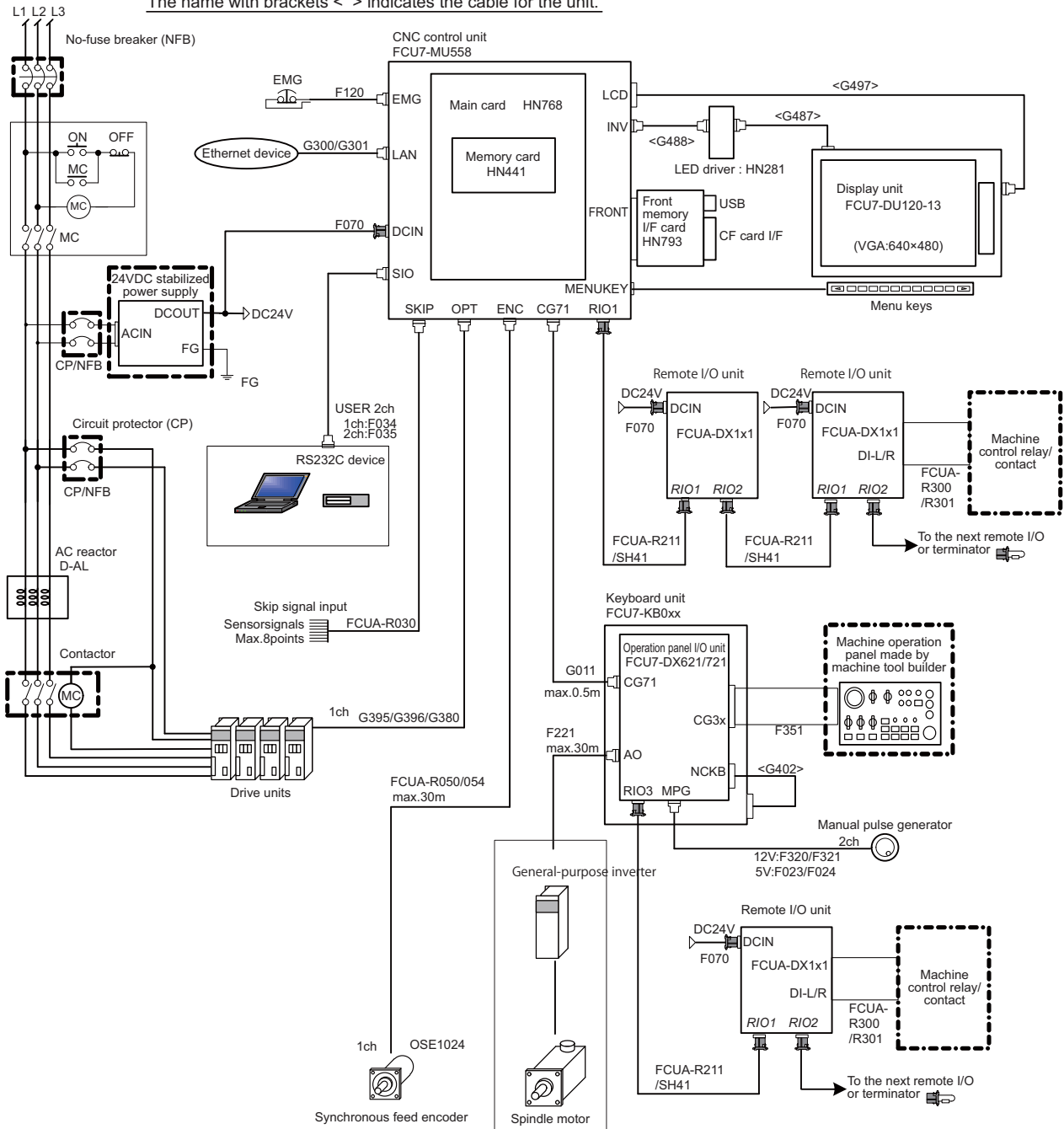

(Note 1) For information on how to connect the drive unit, refer to the drive unit's manual.

(Note 2) For a connection of the MITSUBISHI CNC Machine Operation Panel, refer to "Connection: Connection of MITSUBISHI CNC Machine Operation Panel" to be described.

1.3 List of Configuration

1.3.1 List of Units

Classification	Type	Components	Remarks
[Control unit]			
NC functions and display controller	FCU7-MU558	Main control card Memory card Front side memory I/F card	Export Tarde Control Order and Foreign Exchange Order noncompliant unit
[Display unit]			
8.4-type color TFT (VGA:640*480)	FCU7-DU120-13	LCD panel Backlight driver Menu keys Driver cable LED backlight cable LCD cable	Front side memory I/F is normally equipped with the control unit
[Keyboard unit]			
Keyboard for 8.4-type display unit Sheet keys	FCU7-KB024	Escutcheon, key switch G402 cable	ONG layout (for M system/L system, XYZ)
Keyboard for 8.4-type display unit Lathe system sheet keys	FCU7-KB025	Escutcheon, key switch G402 cable	ONG layout (for L system, XZF)
[Operation panel I/O unit]			
DI 24V/0V common input DO Source output AO Analog output	FCU7-DX621	Base card Terminator (R-TM) Add-on card	DI: 64-points 24V/0V common type DO: 48-points source type MPG:2ch AO: 1 point Occupied stations (fixed): 1, 2, 3, 7, 8 RIO3 extensible stations: 4, 5, 6
DI 24V/0V common input DO Source output	FCU7-DX711	Base card Terminator (R-TM)	DI: 64-points 24V/0V common type DO: 64-points source type MPG:2ch Occupied stations (fixed): 1, 2, 7, 8 RIO3 extensible stations: 3, 4, 5, 6
DI 24V/0V common input DO Source output AO Analog output	FCU7-DX721	Base card Terminator (R-TM) Add-on card	DI: 96-points 24V/0V common type DO: 80-points source type MPG:2ch AO: 1 point Occupied stations (fixed): 1, 2, 3, 7, 8 RIO3 extensible stations: 4, 5, 6
DI 24V/0V common input DO Source output	FCU7-DX731	Base card Terminator (R-TM) Add-on card	DI: 96-points 24V/0V common type DO: 96-points source type MPG:2ch Occupied stations (fixed): 1, 2, 3, 7, 8 RIO3 extensible stations: 4, 5, 6
[Remote I/O unit]			
DI 24V/0V common input DO Source output	FCUA-DX101	RX312	DI: 32-points 24V/0V common type (photo coupler insulation) DO: 32-points source type (non-insulation) Number of occupied stations: 1
DI 24V/0V common input DO Source output	FCUA-DX111	RX312+RX322-1	DI: 64-points 24V/0V common type (photo coupler insulation) DO: 48-points source type (non-insulation) Number of occupied stations: 2
DI 24V/0V common input DO Source output AO Analog output	FCUA-DX121	RX312+RX322	DI: 64-points 24V/0V common type (photo coupler insulation) DO: 48-points source type (non-insulation) AO: 1 point Number of occupied stations: 2
DI 24V/0V common input DO Source output AI Analog input AO Analog output	FCUA-DX141	RX312+RX341	DI: 32-points 24V/0V common type (photo coupler insulation) DO: 32-points source type (non-insulation) AI: 4 points AO: 1 point Number of occupied stations: 2

1 System Configuration

Classification	Type	Components	Remarks
[External power supply unit]			
External power supply with power supply ON/OFF function	PD25	Power supply card Case set	Input 200VAC Output 24VDC (3A)
[Manual pulse generator]			
5V Manual pulse generator	UFO-01-2Z9	UFO-01-2Z9 (Produced by NIDEC NEMICON)	Input 5VDC 100pulse/rev
12V Manual pulse generator	HD60C	HD60C	Input 12VDC 25pulse/rev
[Encoder]			
Synchronous feed encoder	OSE1024-3-15-68	OSE1024-3-15-68	Input 5VDC 1024pulse/rev
[MITSUBISHI CNC machine operation panel]			
MITSUBISHI CNC machine operation panel A	FCU7-KB921	Escutcheon, key switch control card	Mitsubishi standard 55 key
MITSUBISHI CNC machine operation panel B	FCU7-KB926	Escutcheon, Switch	
[Cable connector sets]			
For ENC,SKIP,SIO,MPG,AO	FCUA-CS000	Connector (10120-3000VE,2pcs), Shell kit (10320-52F0-008,2pcs)	
For RIO	FCUA-CS301	Connector (7940-6500SC,4pcs.), Strain relief (3448-7940,2pcs.)	
For PD25/PD27 ACIN	FCUA-CN200	Connector (2-178128-3), Contact (1-175218-5,3pcs.)	
For PD25/PD27 DCOUT	3-178127-6 1-175218-5	Connector (3-178127-6), Contact (1-175218-5,6pcs.)	
For PD25/PD27 ON/OFF	1-178288-5 1-175218-5	Connector (1-178288-5), Contact (1-175218-5,6pcs.)	
For EMG F120	005057-9403 0016020103	Connector (005057-9403), Contact (0016020103,3pcs.)	
For RIO	FCUA-CN211	Connector (1-178288-3), Contact (1-175218-2,3pcs.)	
For DCIN,F070	FCUA-CN220	Connector (2-178288-3), Contact (1-175218-5,3pcs)	
For DIO	FCUA-CN300	Connector (7940-6500SC,2pcs.)	
[Original manufactured memory card]			
Exclusive CF cards for MITSUBISHI CNC 256MB	FCU7-CF256M	FCU7-CF256M	256MB capacity
Exclusive CF cards for MITSUBISHI CNC 2GB	FCU7-CF002G	FCU7-CF002G	2GB capacity

- (Note 1) Operation panel I/O unit can be mounted on the back side of the keyboard unit.
- (Note 2) Operation panel I/O units for 700 Series (FCU7-DX67x/ FCU7-DX77x) are not available.
- (Note 3) DI: Digital input signals, DO: Digital output signals, AI: Analog input signals, AO: Analog output signals

1.3.2 Durable Parts

Durable parts	Part type
Control unit battery	Q6BAT
Backlight for FCU7-DU120-13(*)	84LHS16
Key sheet for FCU7-KB024	N330B532G51
Key sheet for FCU7-KB025	N330B532G52

(*) Contact the Service Center, Service Station, Sales Office or delayer for repairs or part replacement.

1.3.3 Replacements

Replacements	Part type
Protection fuse	LM40

1.3.4 List of Cables

Type	Application	Length (m) of cables provided by Mitsubishi	Max. cable length
CNP2E-1-xM	Motor side PLG cable	2, 3, 4, 5, 7, 10, 15, 20, 25, 30	30m
CNP3EZ-2P-xM	Spindle side detector cable	2, 3, 4, 5, 7, 10, 15, 20, 25, 30	30m
CNP3EZ-3P-xM	Spindle side detector cable	2, 3, 4, 5, 7, 10, 15, 20, 25, 30	30m
CNV22J-K1P-0.3M	Detector extension cable for HF-KP motor	0.3	0.3m
CNV22J-K2P-0.3M	Detector extension cable for HF-KP motor	0.3	0.3m
CNV2E-8P-xM	Motor side detector cable (for A74(N)/A51/A48)/ Ball screw side detector cable	2, 3, 4, 5, 7, 10, 15, 20, 25, 30	30m
CNV2E-9P-xM	Motor side detector cable (for A74(N)/A51/A48)/ Ball screw side detector cable	2, 3, 4, 5, 7, 10, 15, 20, 25, 30	30m
CNV2E-HP-xM	MDS-B-HR unit cable	2, 3, 4, 5, 7, 10, 15, 20, 25, 30	30m
CNV2E-K1P-xM	Detector cable for HF-KP motor (load side angle)	2, 3, 5, 7, 10	10m
CNV2E-K2P-xM	Detector cable for HF-KP motor (reverse load side angle)	2, 3, 5, 7, 10	10m
DG21-xM	Battery cable (For drive unit - battery unit)	0.3, 0.5, 1, 5	5m
DG22-xM	Battery cable (For servo drive unit - servo drive unit) * This cable is required to supply the power from the battery unit to multiple drive units.	0.3, 0.5, 1, 2, 3, 5, 7, 10	10m
DG23-xM	Battery cable (For servo drive unit -battery box)	0.3, 0.5, 1, 2, 3, 5, 7, 10	10m
DG24-xM	5V spply/DO output cable (For servo drive unit -battery box)	0.3, 0.5, 1, 2, 3, 5, 7, 10	10m
DG25-xM	Battery cable (For servo drive unit -battery box)	0.3, 0.5, 1, 2, 3, 5, 7, 10	10m
F023 LxM	Manual pulse generator cable (5V): 1ch (for connection to operation panel I/O unit)	1, 2, 3, 5, 8, 10, 15, 20	20m
F024 LxM	Manual pulse generator cable (5V): 2ch (for connection to operation panel I/O unit)	1, 2, 3, 5, 8, 10, 15, 20	20m
F034 LxM	RS-232C I/F cable: 1ch	0.5, 1, 2, 3, 5, 8, 10	15m (*)
F035 LxM	RS-232C I/F cable: 2ch	0.5, 1, 2, 3, 5, 8, 10	15m (*)
F070 LxM	24VDC power cable	0.5, 1.5, 3, 5, 8, 10, 15, 20	30m
F110 LxM	24VDC power cable for PD25	0.5, 1.5, 3, 5, 8, 10, 15	15m
F120 LxM	Emergency stop cable	0.5, 1.5, 3, 5, 8, 10, 15, 20	30m
F170 LxM	ON/OFF switch cable for PD25	0.5, 1.5, 3, 5, 8, 10, 15	15m
F221 LxM	Analog output cable	1, 2, 3, 5, 8, 10, 15, 20	30m
F320 LxM	Manual pulse generator cable (12V): 1ch (for connection to operation panel I/O unit)	1, 2, 3, 5, 8, 10, 15, 20	50m
F321 LxM	Manual pulse generator cable (12V): 2ch (for connection to operation panel I/O unit)	1, 2, 3, 5, 8, 10, 15, 20	50m
F351	DI/DO cable (one side connector) (for operation panel I/O unit)	3	50m
FCUA-R030-xM	SKIP input	3, 7	20m
FCUA-R031-xM	Analog input/output	2, 3, 7	30m
FCUA-R050-xM	Encoder input (straight, with connector)	5	30m
FCUA-R054-xM	Encoder input (right angle, with connector)	3, 5, 10, 15, 20	30m
FCUA-R211-xM	Remote I/O (with terminal block)	0.3, 1, 2, 3, 5, 8, 10, 15, 20	30m (*)
FCUA-R300	DI/DO cable (one side connector) (for remote I/O unit)	3	50m
FCUA-R301-xM	DI/DO cable (both side connectors) (for remote I/O unit)	1, 2, 3, 5	50m
G011 LxM	Operation panel I/O interface cable	0.5	0.5m
G023 LxM	Manual pulse generator cable (5V): 1ch (for connection to control unit)	1, 2, 3, 5, 8, 10, 15, 20	20m (*)
G024 LxM	Manual pulse generator cable (5V): 2ch (for connection to control unit)	1, 2, 3, 5, 8, 10, 15, 20	20m (*)
G071 xM	DC24V relay cable for MITSUBISHI CNC machine operation panel	0.5	0.5m
G300 LxM	LAN cross cable (Shielded cable is recommended when the length will be 1m or more)	1, 3, 5, 10	10m
G301 LxM	LAN straight cable (Shielded cable is recommended when the length will be 1m or more)	1	1m
G380 LxM	Optical communication cable (PCF type with reinforced sheath) (for wiring outside of the panel)	5, 10, 12, 15, 20, 25, 30	30m
G395 LxM	Optical communication cable (POF type with reinforced sheath) (for wiring outside of the panel)	3, 5, 7, 10	10m
G396 LxM	Optical communication cable (POF type without reinforced sheath) (for wiring inside of the panel)	0.3, 0.5, 1, 2, 3, 5	10m
G460 xM	Cable between MITSUBISHI CNC machine operation panel A and MITSUBISHI CNC machine operation panel B	0.5	0.5m

1 System Configuration

Type	Application	Length (m) of cables provided by Mitsubishi	Max. cable length
MR-BKS1CBLxM-A1-H	Brake cable for HF-KP motor (load side angle)	2, 3, 5, 7, 10	10m
MR-BKS1CBLxM-A2-H	Brake cable for HF-KP motor (reverse load side angle)	2, 3, 5, 7, 10	10m
MR-PWS1CBLxM-A1-H	Power cable for HF-KP motor (load side angle)	2, 3, 5, 7, 10	10m
MR-PWS1CBLxM-A2-H	Power cable for HF-KP motor (reverse load side angle)	2, 3, 5, 7, 10	10m
R-TM	Remote I/O Interface terminator	-	-
SH21 xM	Power supply communication cable	0.35, 0.5, 1, 2, 3, 5, 10, 15, 20, 30	30m
SH41 xM	Remote I/O (between units in a panel)	0.3, 0.5, 0.7	1m (*)

(Note 1) Asterisks "x" in type columns indicate cable length (unit: m).

(Note 2) Lengths indicated with an asterisk (*) in the max. cable length column indicate the maximum cable length when connecting via other unit.

General Specifications

2.1 Environment Conditions

Item	Unit name		Control unit	Display unit	Keyboard unit	Operation panel I/O unit	Machine operation panel
	Type		FCU7-MU558	FCU7-DU120-13	FCU7-KB024/025	FCU7-DX621/711/721/731	FCU7-KB921/926
General specifications	Ambient temperature	During operation	0 to 55C°				
		During storage	-20 to 60C°				
	Ambient humidity	Long term	10 to 75% RH (with no dew condensation)				
		Short term	10 to 95% RH (with no dew condensation) (Note 1)				
	Vibration resistance		4.9m/s ² or less (during operation)				
	Shock resistance		29.4m/s ² or less (during operation)				
	Working atmosphere		No corrosive gases, dust or oil mist				
Required power specifications	Power voltage		24VDC ±5% Ripple noise 200mV (P-P)	3.3V/12VDC	5VDC	3.3V/5VDC	24VDC ±5%(Note 7)
	Power capacity		24V 2.5A	-	-	- (Note 2)	0.25A(Note 7)
	Instantaneous stop tolerance time		20ms				-
Others	Heating value	(max.)	12.0W	3.3W	1.0W	Control section: 5.0W (Note 3)	6W
	Mass	(kg)	1.0	1.5	0.8	0.4	FCU7-KB921:1.2 FCU7-KB926:0.5
	Outline dimension	(mm)	235(width) x 173(height) x 73(depth) (Depth from the plate mounting surface: 60)	260(width) x 200(height)	140(width) x 200(height)	120(width) x 180(height)	FCU7-KB921: 260(W) x 140(H) FCU7-KB926: 140(W) x 140(H)

Item	Unit name		Remote I/O unit			
	Type		FCUA-DX101	FCUA-DX111	FCUA-DX121	FCUA-DX141
General specifications	Ambient temperature	During operation	0 to 55C°			
		During storage	-20 to 60C°			
	Ambient humidity	Long term	10 to 75% RH (with no dew condensation)			
		Short term	10 to 95% RH (with no dew condensation) (Note 1)			
	Vibration resistance		4.9m/s ² or less (during operation)			
	Shock resistance		29.4m/s ² or less (during operation)			
Working atmosphere		No corrosive gases or dust				
Required power specifications	Input power voltage		24VDC±5% Ripple noise 200mV (P-P)			
	Power capacity		24V 0.7A (Note 4)	24V 1.5A (Note 4)	24V 0.7A (Note 4)	24V 0.7A (Note 4)
	Instantaneous stop tolerance time		-			
Others	Heating value	(max.)	25W (Note 5)	30W (Note 5)	30W (Note 5)	30W (Note 5)
	Mass	(kg)	0.5	0.6	0.6	0.6

(Note 1) "Short term" means within one month.

(Note 2) For the current value of the I/O circuit, calculate with the number of points used and load.

(Note 3) For the heating value of the I/O circuit, calculate with the number of points used.

(Note 4) Allows only the amount to be consumed by control circuit.

(Note 5) Differs according to the number of machine input operation points and the load and number of points connected to the machine output. The maximum value applies when all points are ON.

(Note 6) These units, which are open equipments, must be installed within a sealed metal control panel.

(Note 7) FCU7-KB926 does not need 24VDC power supply input.

2.2 Control Unit

Dimension and names of parts

[FCU7-MU558]

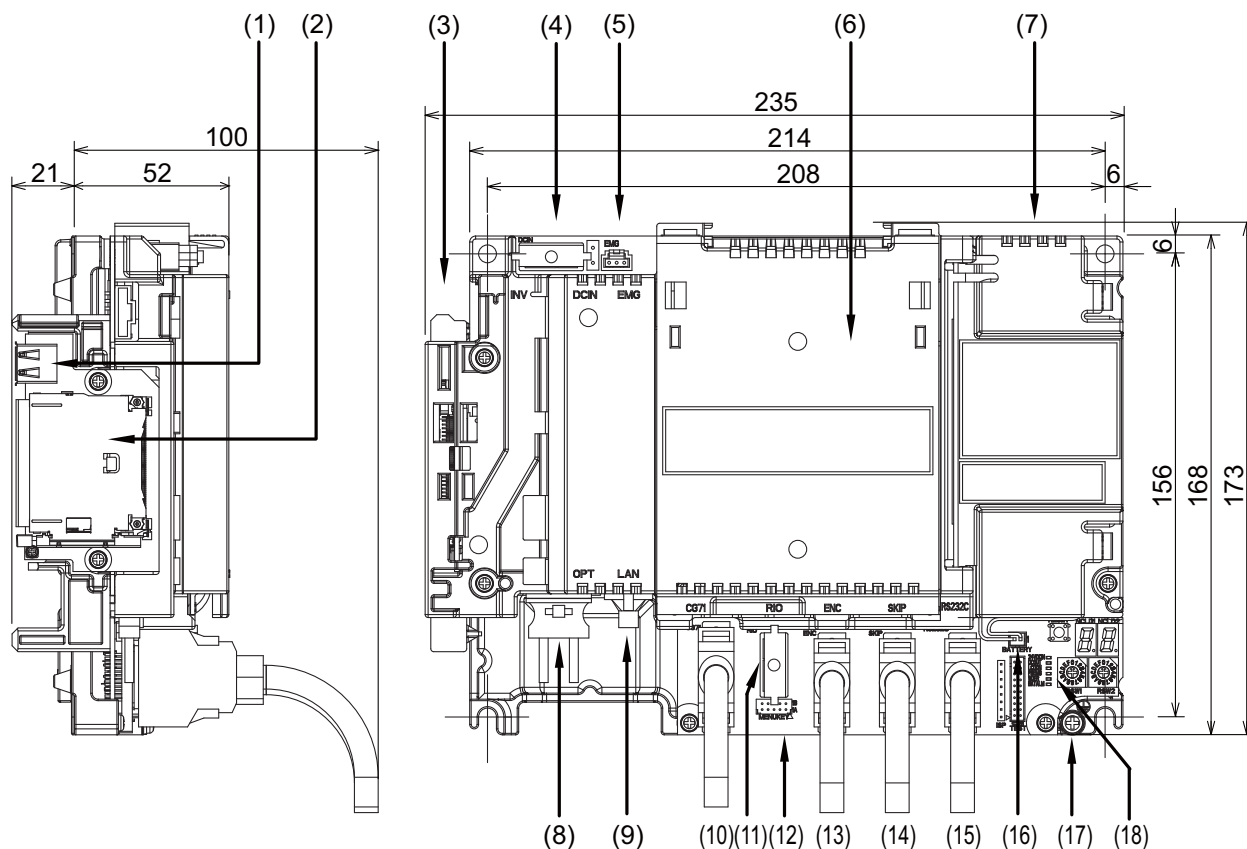

No.	Connector name	Function	No.	Connector name	Function
(1)	USB	Front USB memory I/F	(11)	RIO1	Remote I/O unit I/F
(2)	CF	Front CF card I/F	(12)	MENUKEY	Menu key I/F
(3)	INV	Display unit backlight driver I/F	(13)	ENC	Encoder input 1ch (5V manual pulse generator input 2ch)
(4)	DCIN	24VDC input	(14)	SKIP	Skip input 8ch
(5)	EMG	External emergency stop input	(15)	SIO	Serial communication (RS- 232C) I/F 2ch
(6)	ADONCCB	Expansion card slot	(16)	BAT	Battery (Q6BAT) I/F
(7)	LCD	Display unit signal I/F	(17)	FG	FG terminal
(8)	OPT	Optical communication I/F	(18)		LED
(9)	LAN	Ethernet I/F			
(10)	CG71	Operation panel I/O unit I/F			

(1) Front USB memory I/F (USB)

Do not connect devices other than USB memories.

When using a commercially available USB memory, performance check must be made by machine tool builder.

(2) Front CF card I/F (CF)

It is recommended to use CF cards of the original equipment manufactured parts.

Mitsubishi is unable to guarantee the machine operation when a commercially available CF card or SD memory card (SD-CF adapter is required) is used. In that case, performance check must be made carefully by machine tool builder.

(Refer to "General Specifications: Exclusive CF cards for MITSUBISHI CNC: Precautions for Use of Commercially Available CF Cards".)

(3) Display unit backlight driver I/F (INV)

(4) 24VDC input (DCIN)

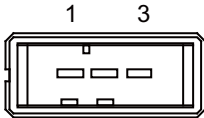

1	I	+24V
2		0V
3		FG

<Cable side connector type>

Connector: 2-178288-3

Contact: 1-175218-5 x3

Recommended manufacturer: Tyco Electronics

(a) Specifications of power supply

Consider the following characteristics when selecting the stabilized power supply (prepared by machine tool builder). Use a power supply that complies with CE Marking or that follows the safety standards given below.

[Stabilized power supply selection items]

Item		Standard setting
Output	Voltage fluctuation	±5% or less of 24VDC
	Ripple noise	200mV (P-P)
Power capacity		2.5A or more
Output holding time		20ms
Overcurrent protection		Required

[Standards]

Safety Standards: UL1950, CSA C22.2 No.234 approved, IEC950 compliant

Noise Terminal Voltage: FCC Class A, VCCI-Class A

High Harmonics Current Restrictions: IEC61000-3-2

(Note) 24VDC voltage may drop instantaneously due to rush current at the beginning of 24V power supply to the control unit. The level of voltage drop depends on the capacity of the power supply. Do not share the power supply with the devices that have alarms to warn the voltage drop.

⚠ CAUTION

1. Using a stabilized power supply without overcurrent protection may cause the unit's failure due to miswiring of 24V.

(5) External emergency stop input (EMG)

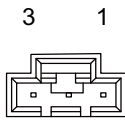

1		FG
2	I	EMG IN
3	O	+24V

* Be sure to connect EMG terminal cable (G123) to the connector when not used.

<Cable side connector type>

Connector: 005057-9403
Contact: 0016020103
Recommended manufacturer: MOLEX

(6) Expansion card slot (ADONCCB)

(7) Display unit signal I/F (LCD)

(8) Optical communication I/F (OPT)

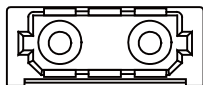

<Cable side connector type>

(PCF type)

Connector: CF-2D101-S
Recommended manufacturer: Japan Aviation Electronics

(POF type)

Connector: PF-2D101
Recommended manufacturer: Japan Aviation Electronics

(9) Ethernet I/F (LAN)

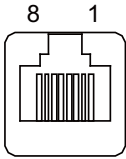

1	O	TD+
2	O	TD-
3	I	RD+
4		
5		
6	I	RD-
7		
8		

* Connect connector case with FG pattern.

* Use cross cable (G300) when directly connecting a device such as a personal computer to the unit.

<Cable side connector type>

Connector: 5-569550-3

Recommended manufacturer: Tyco Electronics

(10) Operation panel I/O unit I/F (CG71)

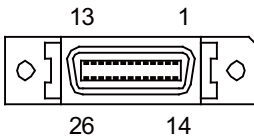

1		GND	14		GND
2		5V	15		5V
3		5V	16		3.3V
4		GND	17		GND
5	O	KBCS0*	18	O	KBCS1*
6	O	KBCS2*	19	O	KBAD0
7	O	KBAD1	20	O	KBAD2
8	I	KBD0	21	I	KBD1
9	I	KBD2	22	I	KBD3
10	O	KBRES*	23	O	RDYOUT*
11	O	BUZOUT*	24		3.3V
12	I/O	TXRX3	25	I/O	TXRX3*
13	O	SCAN36	26	O	SCAN37

* Connect connector case with FG pattern.

<Cable side connector type>

Plug: 10126-3000VE

Shell: 10326-52F0-008

Recommended manufacturer: 3M

(11) Remote I/O unit I/F (RIO1)

Up to eight remote I/O stations can be connected.

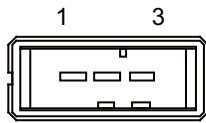

1	I/O	TXRX1
2	I/O	TXRX1*
3		0V

<Cable side connector type>

Connector: 1-178288-3

Contact: 1-175218-2 x3

Recommended manufacturer: Tyco Electronics

(12) Menu key I/F (MENUKEY)

(13) Encoder input 1ch/ 5V manual pulse generator input 2ch (ENC)

Synchronous feed encoder or 5V manual pulse generator can be connected to this connector.

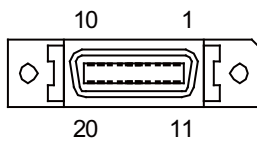

1		0V	11		0V
2	I	ENC1Z	12	I	ENC1Z*
3	I	ENC1B	13	I	ENC1B*
4	I	ENC1A	14	I	ENC1A*
5		0V	15		0V
6	O	5V	16	O	5V
7	I	HA2A	17	I	HA2B
8	I	HA1A	18	I	HA1B
9		NC	19		NC
10	O	5V	20	O	5V

* Connect connector case with FG pattern.

<Cable side connector type>

Plug: 10120-3000VE

Shell: 10320-52F0-008

Recommended manufacturer: 3M

(a) Input for synchronous feed encoder
 <Specification of input part>

Number of pulse phases		Three phases (A phase, B phase, a phase difference 90 degrees, Z phase) (Refer to the waveform below.)
Signal output of the encoder		Line driver output
Signal voltage	Input voltage range	0V to 5.25V
	Differential-input voltage VIT+	0.2V to 5.25V
	Differential-input voltage VIT-	-5.25V to -0.2V
Power supply voltage		5VDC±10%
Current consumption		200mA or less
Number of pulses per rotation		1024 pulse/rev
Input frequency (rotation speed)		136kHz or less (8000r/min or less)
Cable length		50m or less

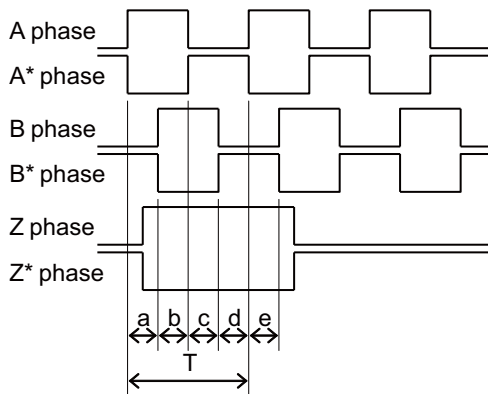

a.b.c.d.e: A phase or B phase rising edge (falling edge) phase difference = $T/4 \pm T/10$

(b) Input for 5V manual pulse generator
 <Specification of input part>

Number of pulse phases		Two phases (A phase, B phase, a phase difference 90 degrees) (Refer to the waveform below.)
Signal output of manual pulse generator		Voltage output, open collector output
Signal voltage		H level 3.5V to 5.25V L level 0V to 0.5V
Power supply voltage		5VDC±10%
Current consumption		100mA or less
Number of pulses per rotation		25 pulse/rev, 100 pulse/rev
Input frequency (rotation speed)		1kHz or less (40r/s or less for 25pulse/rev, 10r/s or less for 100pulse/rev)
Cable length		20m or less

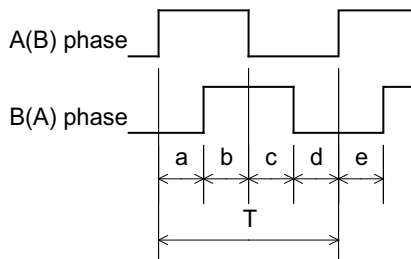

a.b.c.d.e: A phase or B phase rising edge (falling edge) phase difference = $T/4 \pm T/10$

T: A or B phase cycle

(c) 5V manual pulse generator input/output circuit

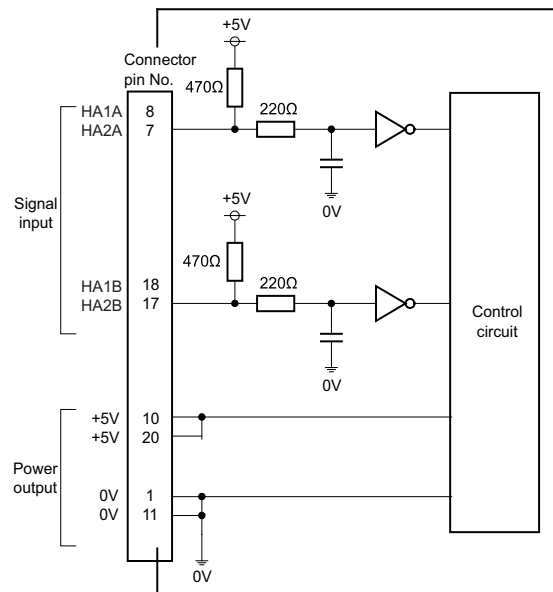

When using the synchronous feed encoder and the manual pulse generator at the same time, connect the manual pulse generator to the operation panel I/O unit or use a distribution cable made by the machine tool builder.

(14) Skip input 8ch (SKIP)

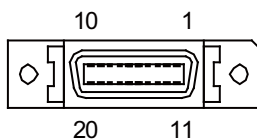

1		COM	11		COM
2	I	SKIP0	12	I	SKIP1
3	I	SKIP2	13	I	SKIP3
4		NC	14		NC
5		COM	15		COM
6		NC	16		NC
7	I	SKIP4	17	I	SKIP5
8	I	SKIP6	18	I	SKIP7
9		NC	19		NC
10		NC	20		NC

* Connect connector case with FG pattern.

<Cable side connector type>

Plug: 10120-3000VE

Shell: 10320-52F0-008

Recommended manufacturer: 3M

(a) Skip signal input conditions

Use the input signal within the following condition ranges.

		24V common	0V common
1	Input voltage at external contact ON	6V or less	18V or more, 25.2V or less
2	Input current at external contact ON	6mA or more	
3	Input voltage at external contact OFF	20V or more, 25.2V or less	4V or less
4	Input current at external contact OFF	2mA or less	
5	Input resistance	Approx. 2.2kΩ	
6	Input signal holding time (Ton)	2ms or more	
7	Internal response time	0.08ms or less	
8	Machine side contact capacity	+30V or more, 16mA or more	

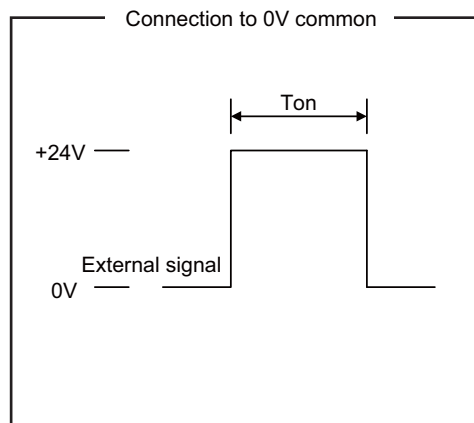
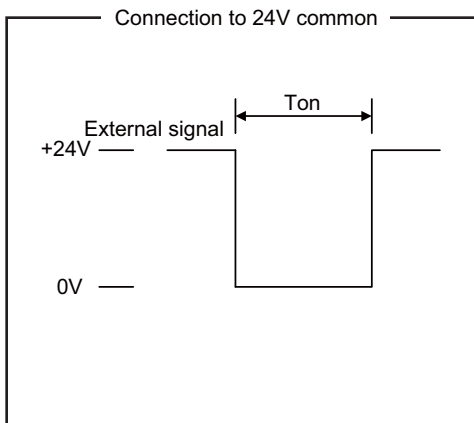

Connection to 24V common

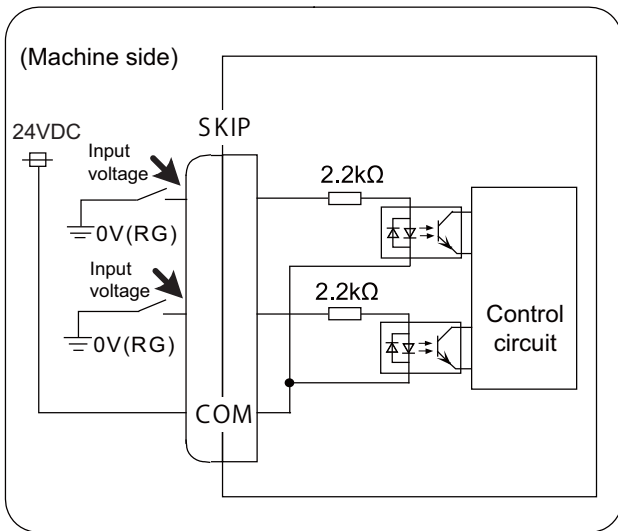

Connection to 0V common

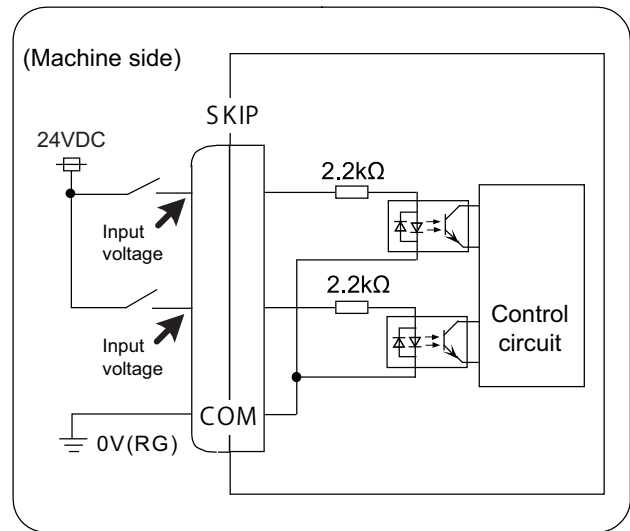

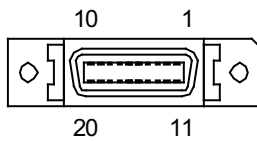
(15) Serial communication (RS-232C) I/F 2ch (SIO)

1		0V	11		0V
2	I	RD1(RXD1)	12	O	SD1(TXD1)
3	I	CS1(CTS1)	13	O	RS1(RTS1)
4	O	DR1(DSR1)	14	I	ER1(DTR1)
5		0V	15		0V
6		NC	16		NC
7	I	RD2(RXD2)	17	O	SD2(TXD2)
8	I	CS2(CTS2)	18	O	RS2(RTS2)
9	O	DR2(DSR2)	19	I	ER2(DTR2)
10		NC	20		NC

* Connect connector case with FG pattern.

<Cable side connector type>

Plug: 10120-3000VE

Shell: 10320-52F0-008

Recommended manufacturer: 3M

(16) Battery (Q6BAT) I/F (BAT)**(17) FG terminal (FG)**

(18) LED

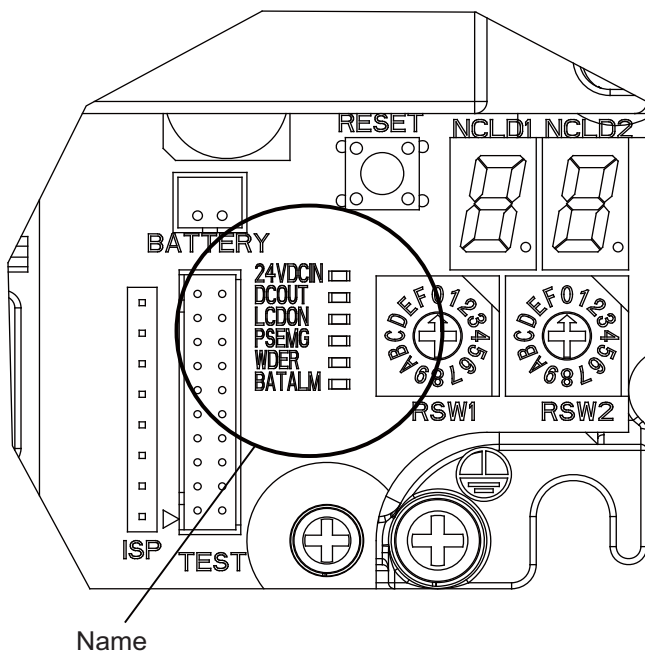

Name	Function	At fault	Conditions
24VDCIN	24VDC input check	Not lit	(1) Failure of 24VDC input (2) Fuse is disconnected near DCIN connector
DCOUT	Internal output voltage check	Not lit	(1) Failure of internal voltage output in control unit (2) Short circuit of 5VDC output on CG71 or ENC
LCDON	12VDC output voltage check for backlight driver	Not lit	(1) Failure of 12VDC output in control unit (2) 24VDC input voltage is +20V or less
PSEMG	External emergency stop status display	Lit (Red)	External emergency stop signal has inputted
WDER	System error display	Lit (Red)	(1) Failure of control unit (2) SRAM data is broken
BATLDM	Battery voltage drop	Lit (Red)	Battery voltage has dropped to 2.7V or less

2.3 Display Unit

Outline dimension

[FCU7-DU120-13 (8.4-type)]

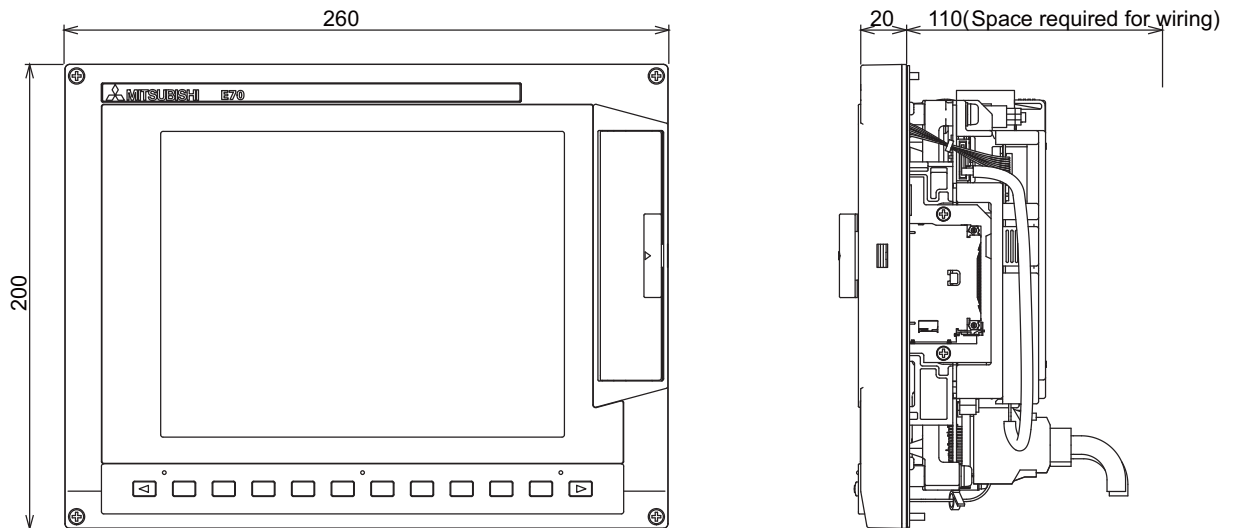

(Note 1) The above side view shows the state with the control unit mounted.

(Note 2) Consider the minimum radius value of optical communication cable for the bottom space. (Refer to "Connection : Precautions for Using Optical Communication Cable".)

<Panel cut dimension drawing>

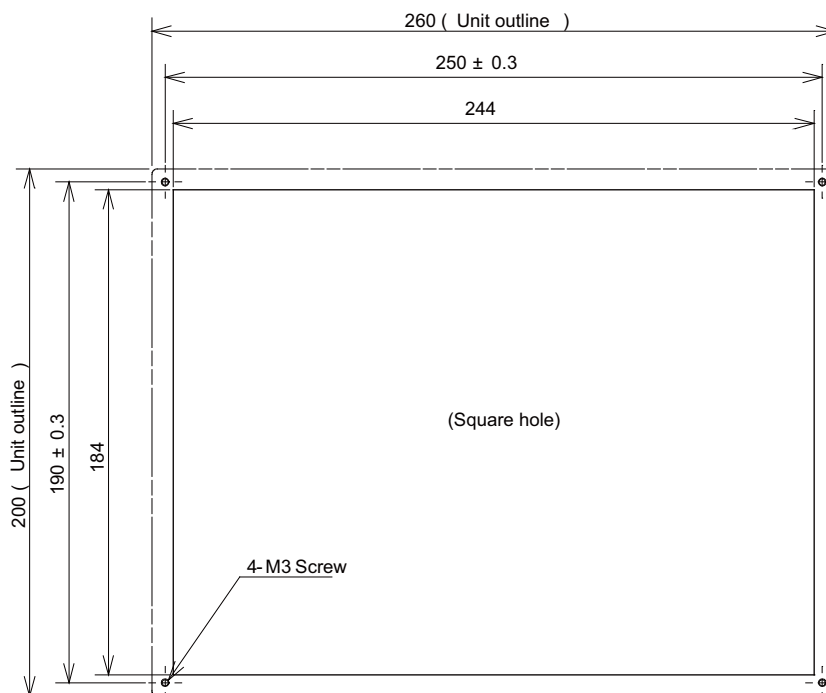

2.4 Keyboard Unit

Outline dimension

[FCU7-KB024 (8.4-type)]

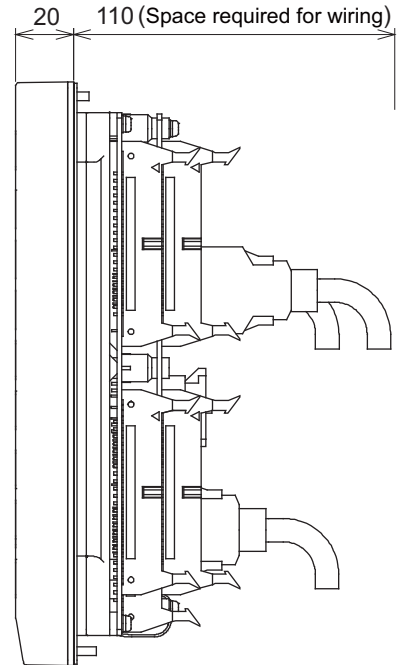
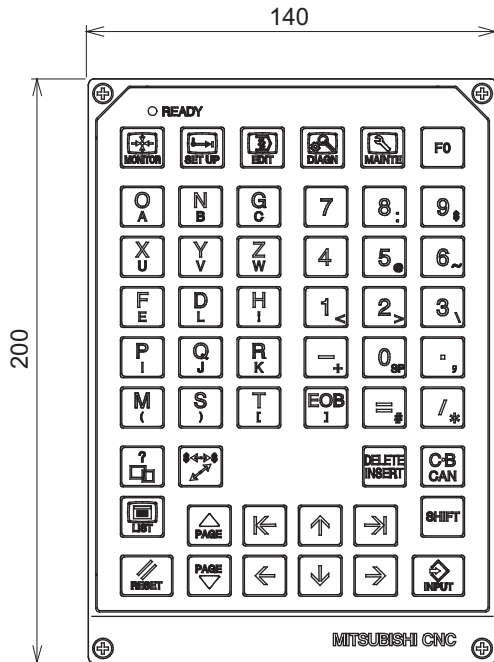

(Note) The above side view shows the state with the operation panel I/O unit FCU7-DX721 mounted.

<Panel cut dimension drawing>

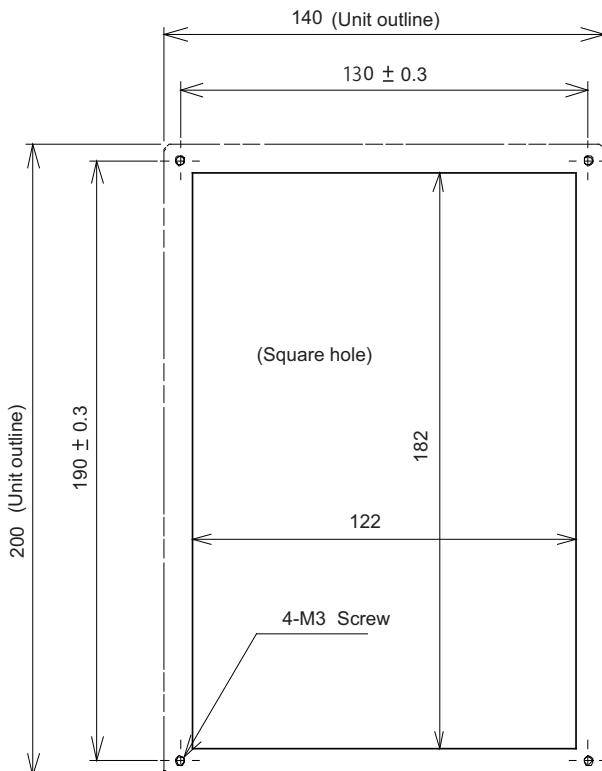

[FCU7-KB025 (8.4-type)]

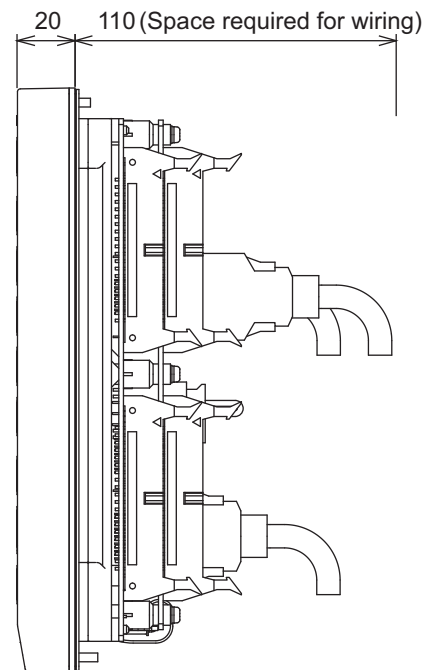
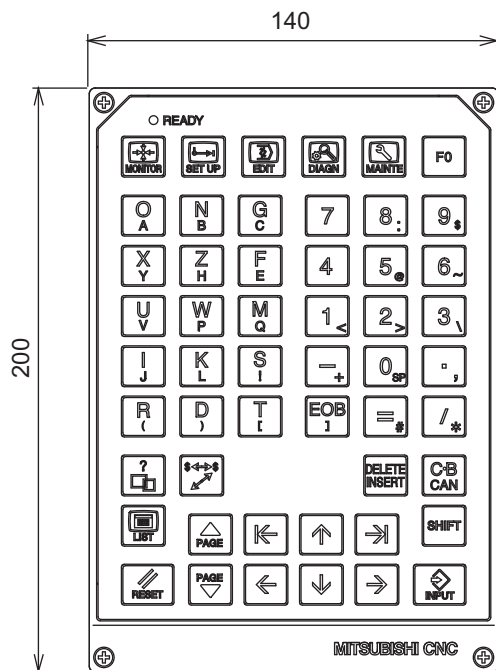

(Note) The above side view shows the state with the operation panel I/O unit FCU7-DX721 mounted.

<Panel cut dimension drawing>

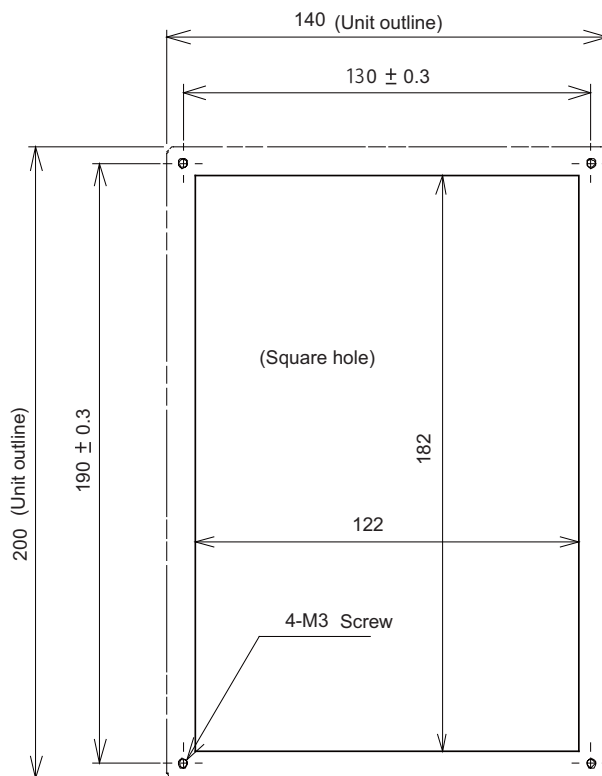

2.5 Operation Panel I/O Unit

Characteristics of operation panel I/O unit are as follows.

- (1) Number of DI/DO points that can be mounted on the machine operation panel is 64/64 at the minimum and 96/96 at the maximum.
Operation panel I/O unit DI/DO uses equivalent serial link connections as those used for remote I/O.
- (2) Remote I/O interface --- 1ch
Extension with remote I/O unit is possible up to 4 stations.
(a) When FCU7-DX711 is used: Up to 4 stations, 128 points/128 points in total, are available.
(b) When any one of FCU7-DX621/721/731 is used: Up to 3 stations, 96 points/96 points in total, are available.
(Note) The maximum number of stations that can be extended is described above whether DI/DO of the operation panel I/O unit is used or not.
- (3) Manual pulse generator --- 2ch
5V and 12V manual pulse generators can be connected.
- (4) Installation on the back side of the keyboard unit is possible. Allows space saving inside the operation panel.

Classification	Type	Components	Remarks
DI 24V/0V common input DO Source output AO Analog output	FCU7-DX621	Base card Terminator (R-TM) Add-on card	DI: 64-points 24V/0V common type DO: 48-points source type MPG:2ch AO: 1 point Occupied stations (fixed): 1, 2, 3, 7, 8 RIO3 extensible stations: 4, 5, 6
DI 24V/0V common input DO Source output	FCU7-DX711	Base card Terminator (R-TM)	DI: 64-points 24V/0V common type DO: 64-points source type MPG:2ch Occupied stations (fixed): 1, 2, 7, 8 RIO3 extensible stations: 3, 4, 5, 6
DI 24V/0V common input DO Source output AO Analog output	FCU7-DX721	Base card Terminator (R-TM) Add-on card	DI: 96-points 24V/0V common type DO: 80-points source type MPG:2ch AO: 1 point Occupied stations (fixed): 1, 2, 3, 7, 8 RIO3 extensible stations: 4, 5, 6
DI 24V/0V common input DO Source output	FCU7-DX731	Base card Terminator (R-TM) Add-on card	DI: 96-points 24V/0V common type DO: 96-points source type MPG:2ch Occupied stations (fixed): 1, 2, 3, 7, 8 RIO3 extensible stations: 4, 5, 6

- (Note 1) The station Nos. occupied by the operation panel I/O unit cannot be changed.
- (Note 2) Set the number of DI points that are simultaneously turned ON to be less than half of the total points. If many points are set to be simultaneously turned ON in high temperature, operation panel I/O unit may be deteriorated due to the heat.

Dimension and names of parts
[FCU7-DX621]

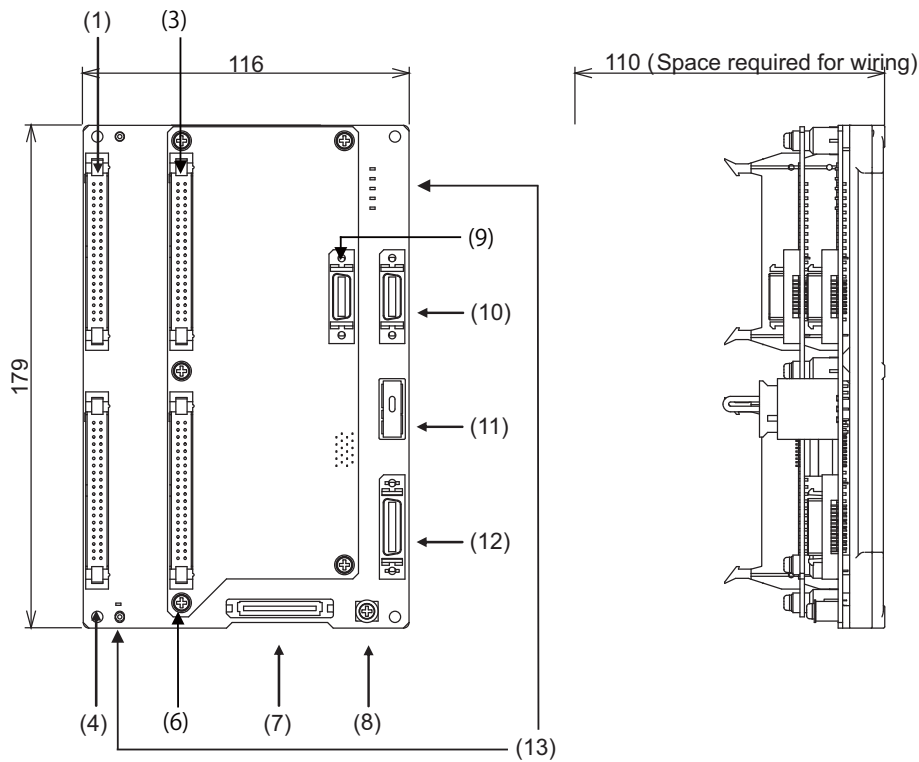

<Dimension drawing for installing on the panel>

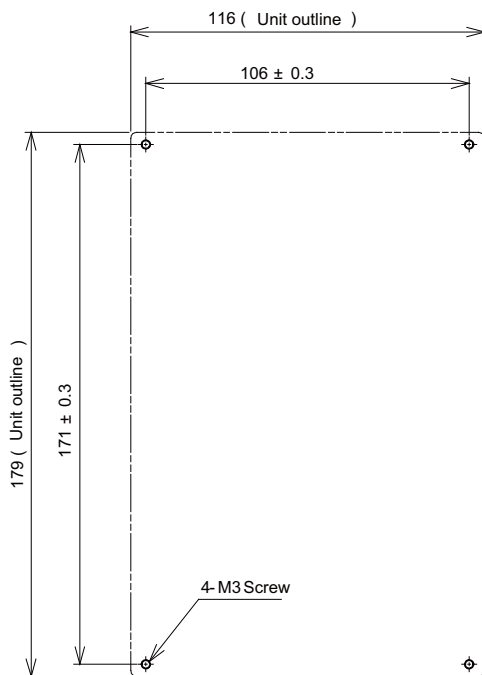

<Installation on the back side of the keyboard>

Operation panel I/O unit can be installed on the back side of the keyboard.

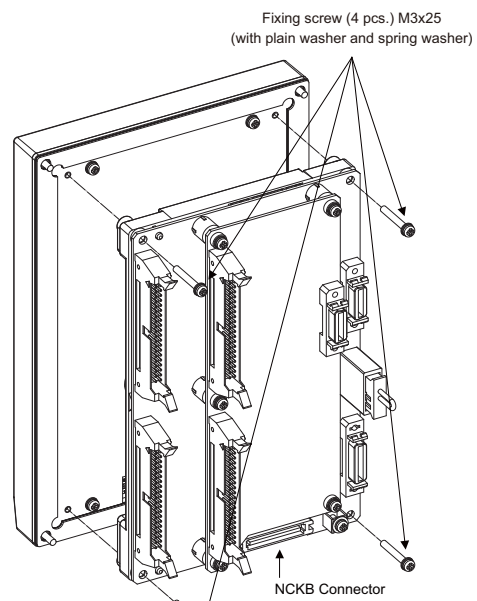

(Note) Use M3x25 screws (with spring washer and plain washer) when mounting the operation panel I/O unit.

[FCU7-DX711]

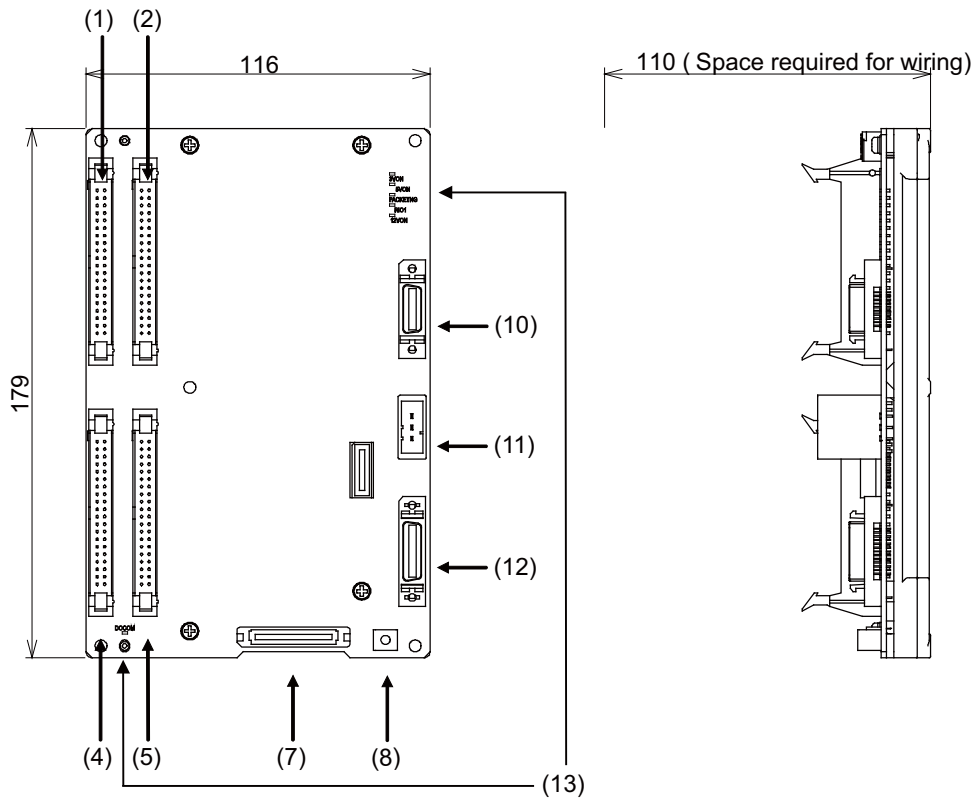

<Dimension drawing for installing on the panel>

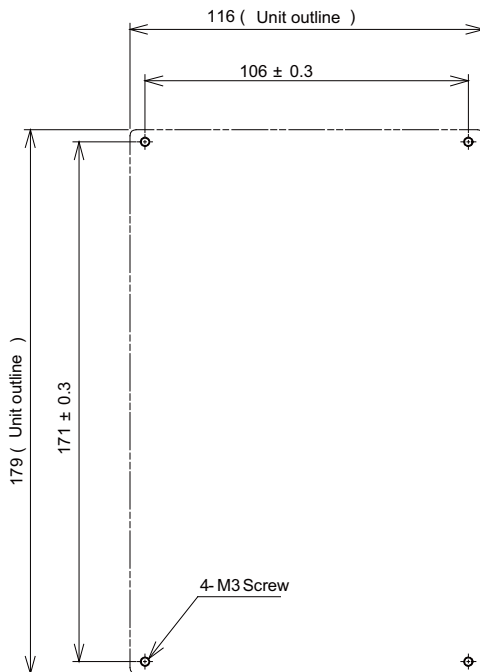

<Installation on the back side of the keyboard>

Operation panel I/O unit can be installed on the back side of the keyboard.

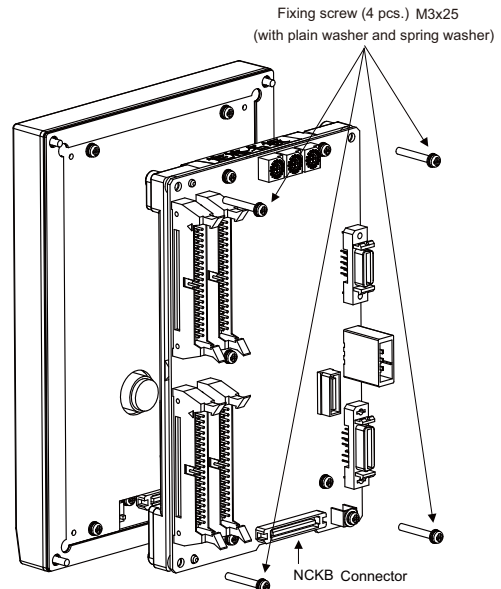

(Note) Use M3x25 screws (with spring washer and plain washer) when mounting the operation panel I/O unit.

[FCU7-DX721/ FCU7-DX731]

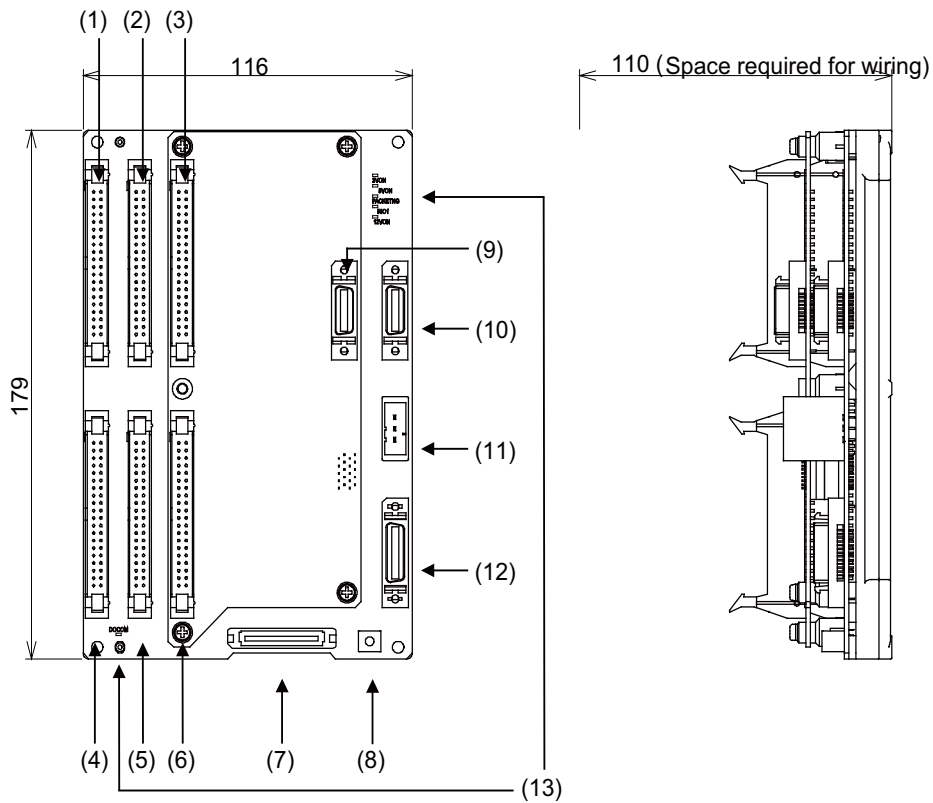

(Note) (9) is not available for FCU7-DX731.

<Dimension drawing for installing on the panel>

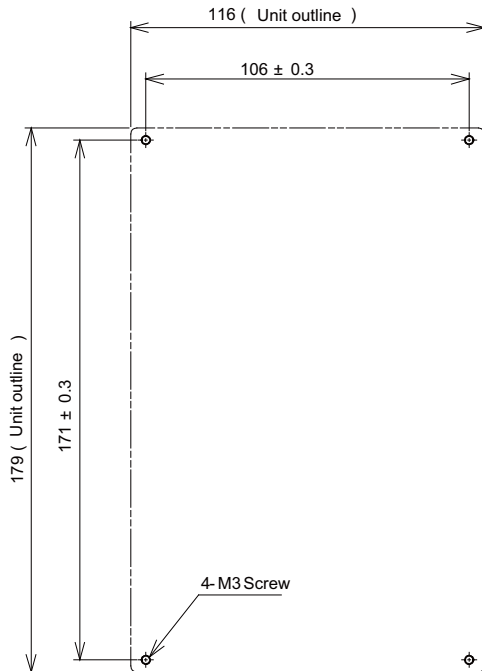

<Installation on the back side of the keyboard>

Operation panel I/O unit can be installed on the back side of the keyboard.

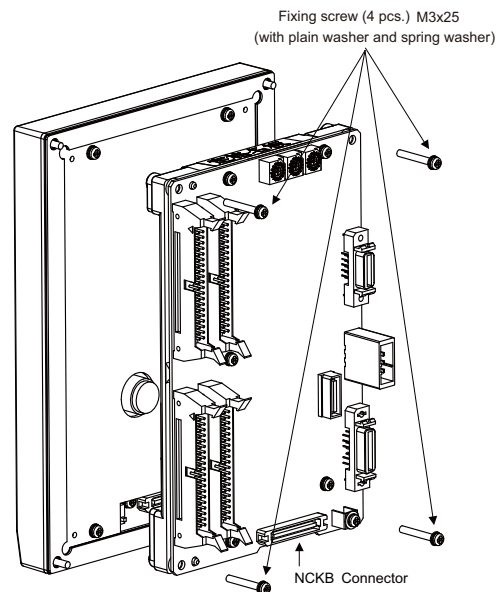

(Note) Use M3x25 screws (with spring washer and plain washer) when mounting the operation panel I/O unit.

(1) Machine input (CG31)

Digital input 32 points (1st station)

(2) Machine input (CG33)

Digital input 32 points (2nd station)

(Note) This is not available for FCU7-DX621.

(3) Machine input (CG35)

Digital input 32 points (3rd station)

(Note) This is not available for FCU7-DX711.

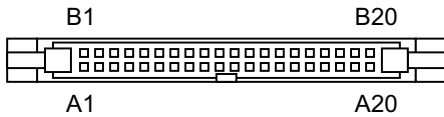

<Cable side connector type>

Connector: 7940-6500SC

Strain relief: 3448-7940

Recommended manufacturer: 3M

CG31				CG33				CG35									
B		A		B		A		B		A							
20	I	X200	20	I	X210	20	I	X220	20	I	X230	20	I	X240	20	I	X250
19	I	X201	19	I	X211	19	I	X221	19	I	X231	19	I	X241	19	I	X251
18	I	X202	18	I	X212	18	I	X222	18	I	X232	18	I	X242	18	I	X252
17	I	X203	17	I	X213	17	I	X223	17	I	X233	17	I	X243	17	I	X253
16	I	X204	16	I	X214	16	I	X224	16	I	X234	16	I	X244	16	I	X254
15	I	X205	15	I	X215	15	I	X225	15	I	X235	15	I	X245	15	I	X255
14	I	X206	14	I	X216	14	I	X226	14	I	X236	14	I	X246	14	I	X256
13	I	X207	13	I	X217	13	I	X227	13	I	X237	13	I	X247	13	I	X257
12	I	X208	12	I	X218	12	I	X228	12	I	X238	12	I	X248	12	I	X258
11	I	X209	11	I	X219	11	I	X229	11	I	X239	11	I	X249	11	I	X259
10	I	X20A	10	I	X21A	10	I	X22A	10	I	X23A	10	I	X24A	10	I	X25A
9	I	X20B	9	I	X21B	9	I	X22B	9	I	X23B	9	I	X24B	9	I	X25B
8	I	X20C	8	I	X21C	8	I	X22C	8	I	X23C	8	I	X24C	8	I	X25C
7	I	X20D	7	I	X21D	7	I	X22D	7	I	X23D	7	I	X24D	7	I	X25D
6	I	X20E	6	I	X21E	6	I	X22E	6	I	X23E	6	I	X24E	6	I	X25E
5	I	X20F	5	I	X21F	5	I	X22F	5	I	X23F	5	I	X24F	5	I	X25F
4		NC	4		NC	4		NC	4		NC	4		NC	4		NC
3		COM	3		COM	3		COM	3		COM	3		COM	3		COM
2	I	+24V	2		0V	2	I	+24V	2		0V	2	I	+24V	2		0V
1	I	+24V	1		0V	1	I	+24V	1		0V	1	I	+24V	1		0V

Each station has fixed input/output assignments. Refer to "PLC Interface Manual" for details.

(a) Outline of digital signal input circuit

Both 24V common and 0V common connections are allowed in the digital signal input circuit. Follow the wiring diagram below for each type.

Input circuit

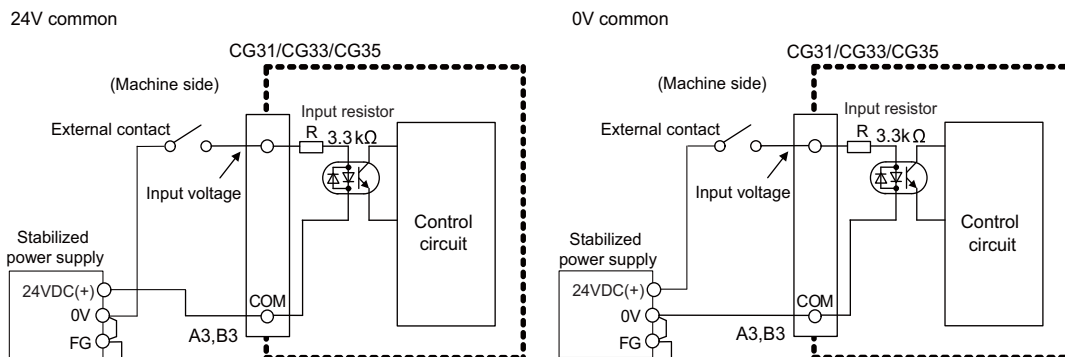

Input conditions

The input signals must be used within the following condition ranges.

		24V common	0V common
1	Input voltage at external contact ON	6V or less	18V or more, 25.2V or less
2	Input current at external contact ON	9mA or more	
3	Input voltage at external contact OFF	20V or more, 25.2V or less	4V or less
4	Input current at external contact OFF	2mA or less	
5	Input resistance	Approx. 3.3kΩ	
6	Tolerable chattering time (T1)	3ms	
7	Input signal holding time (T2)	40ms or more (Note)	
8	Input circuit operation delay time (T3 and T4)	3 to 16ms	
9	Machine side contact capacity	30V or more, 16mA or more	

(Note) Input signal holding time: The guide is 40ms or more. The input signal will not be recognized unless it is held for the ladder processing cycle time or longer.

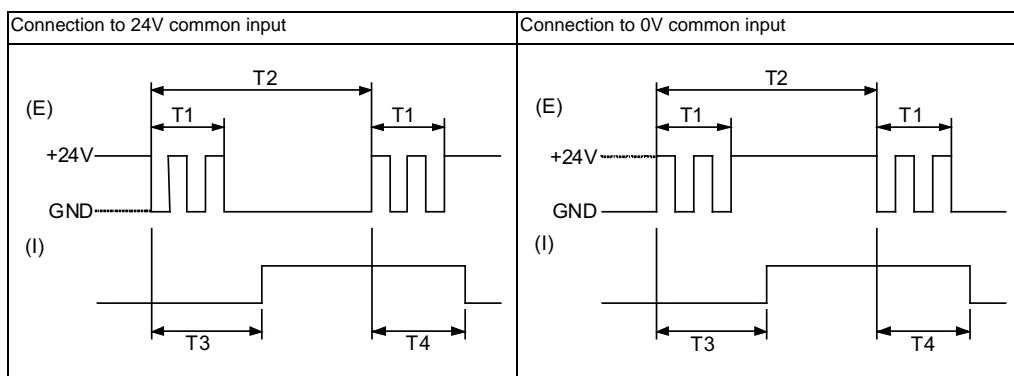

(E) : External signal, (I):Internal signal

(4) Machine output (CG32)

Digital output 32 points (1st station)

(5) Machine output (CG34)

Digital output 32 points (2nd station)

(Note) This is not available for FCU7-DX621.

(6) Machine output (CG36)

FCU7-DX731: Digital output 32 points (3rd station)

FCU7-DX621/DX721: Digital output 16 points (3rd station) (with analog output)

(Note) This is not available for FCU7-DX711.

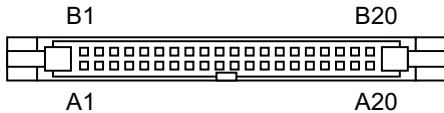

<Cable side connector type>

Connector: 7940-6500SC

Strain relief: 3448-7940

Recommended manufacturer: 3M

CG32				CG34				CG36 (Note 1)			
B		A		B		A		B		A	
20	O	Y200	20	O	Y210	20	O	Y220	20	O	Y250
19	O	Y201	19	O	Y211	19	O	Y221	19	O	Y251
18	O	Y202	18	O	Y212	18	O	Y222	18	O	Y252
17	O	Y203	17	O	Y213	17	O	Y223	17	O	Y253
16	O	Y204	16	O	Y214	16	O	Y224	16	O	Y254
15	O	Y205	15	O	Y215	15	O	Y225	15	O	Y255
14	O	Y206	14	O	Y216	14	O	Y226	14	O	Y256
13	O	Y207	13	O	Y217	13	O	Y227	13	O	Y257
12	O	Y208	12	O	Y218	12	O	Y228	12	O	Y258
11	O	Y209	11	O	Y219	11	O	Y229	11	O	Y259
10	O	Y20A	10	O	Y21A	10	O	Y22A	10	O	Y25A
9	O	Y20B	9	O	Y21B	9	O	Y22B	9	O	Y25B
8	O	Y20C	8	O	Y21C	8	O	Y22C	8	O	Y25C
7	O	Y20D	7	O	Y21D	7	O	Y22D	7	O	Y25D
6	O	Y20E	6	O	Y21E	6	O	Y22E	6	O	Y25E
5	O	Y20F	5	O	Y21F	5	O	Y22F	5	O	Y25F
4		COM (Note 2)	4		COM (Note 2)	4		COM (Note 2)	4		COM (Note 2)
3		COM (Note 2)	3		COM (Note 2)	3		COM (Note 2)	3		COM (Note 2)
2	I	24VDC	2		GND (0V)	2	I	24VDC	2		GND (0V)
1	I	24VDC	1		GND (0V)	1	I	24VDC	1		GND (0V)

(Note 1) FCU7-DX621/DX721 uses 16 points of digital outputs, Y240 to Y24F.

(Note 2) COM (3A, 3B, 4A, and 4B) is connected to 24VDC inside the unit.

Each station has fixed input/output assignments. Refer to "PLC Interface Manual" for details.

(a) Outline of digital signal output circuit

Use within the specification ranges shown below.

Output circuit

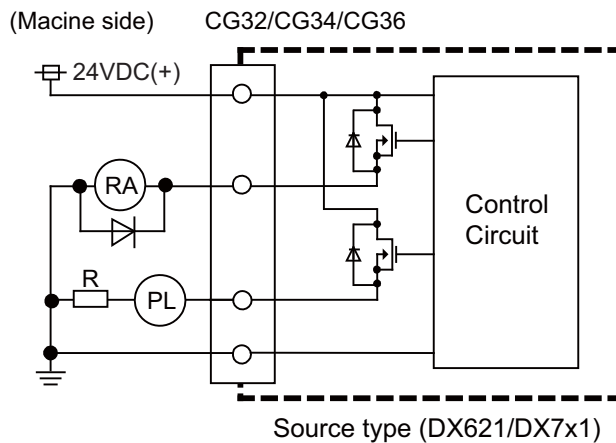

RA : Relay
PL : Pilot lamp

Output conditions

Insulation method	Insulation
Rated load voltage	24VDC
Max. output current	60mA/point
Output delay time	40μs

(Note 1) When using an inductive load such as a relay, always connect a diode (voltage resistance 100V or more, 100mA or more) in parallel to the load.

(Note 2) When using a capacitive load such as a lamp, always connect a protective resistor (R=150Ω) serially to the load to suppress rush currents. (Make sure that the current is less than the above tolerable current including the momentary current.)

⚠ CAUTION

1. When using an inductive load such as a relay, always connect a diode in parallel to the load.
2. When using a capacitive load such as a lamp, always connect a protective resistor serially to the load to suppress rush currents.

(7) Keyboard I/F (NCKB)

(8) FG terminal (FG)

(9) Analog output 1ch (AO)

(Note) This is not available for FCU7-DX731.

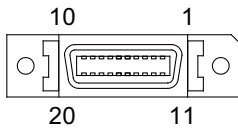

1		AO*	11		NC
2		NC	12		NC
3		NC	13		NC
4		NC	14		NC
5		NC	15		NC
6		NC	16		NC
7	○	AO	17		NC
8		NC	18		NC
9		NC	19		NC
10		NC	20		NC

* Connect connector case with FG pattern.

<Cable side connector type>

Plug: 10120-3000VE

Shell: 10320-52F0-008

Recommended manufacturer: 3M

Output circuit

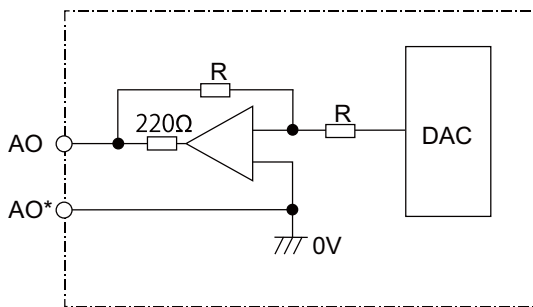

Output conditions

Output voltage	0V to ±10V (±5%)
Resolution	12bit (±10V × n/4096) (Note)
Load conditions	10kΩ load resistance
Output impedance	220Ω

(Note) $n=(2^0 \text{ to } 2^{11})$

Connector pin assignment

1	AO*	GND
7	AO	Analog voltage output

(10) Manual pulse generator input 2ch (5V and 12V) (MPG)

5V manual pulse generator and 12V manual pulse generator can be connected to this connector.
Connect the synchronous feed encoder to the ENC connector of the control unit.

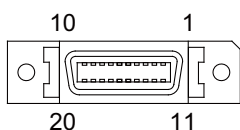

1		GND	11		GND
2		reserve	12		reserve
3	I	HA2A	13	I	HA2B
4	I	HA1A	14	I	HA1B
5		GND	15		GND
6	O	12VDC	16	O	12VDC
7		reserve	17		reserve
8		reserve	18		reserve
9		reserve	19		reserve
10	O	5VDC	20	O	5VDC

* Connect connector case with FG pattern.

<Cable side connector type>

Plug: 10120-3000VE
Shell: 10320-52F0-008
Recommended manufacturer: 3M

<Specification of input part>

	5V manual pulse generator	12V manual pulse generator
Number of pulse phases	Two phases (A phase, B phase, a phase difference 90 degrees) (Refer to the waveform below.)	
Signal output of manual pulse generator	Voltage output, open collector output	Open collector output
Signal voltage	H level 3.5V to 5.25V L level 0V to 0.5V	
Power supply voltage	5VDC±10%	12VDC±10%
Current consumption	100mA or less	
Number of pulses per rotation	25 pulse/rev, 100 pulse/rev	
Input frequency (rotation speed)	1kHz or less (40r/s or less for 25pulse/rev, 10r/s or less for 100pulse/rev)	
Cable length	20m or less	50m or less

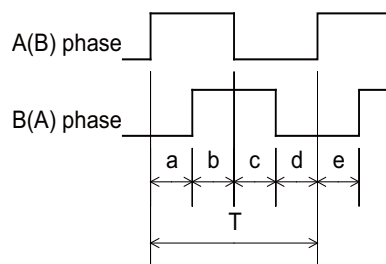

a.b.c.d.e: A phase or B phase rising edge (falling edge) phase difference = $T/4 \pm T/10$
T: A or B phase cycle

<Input/output circuit>

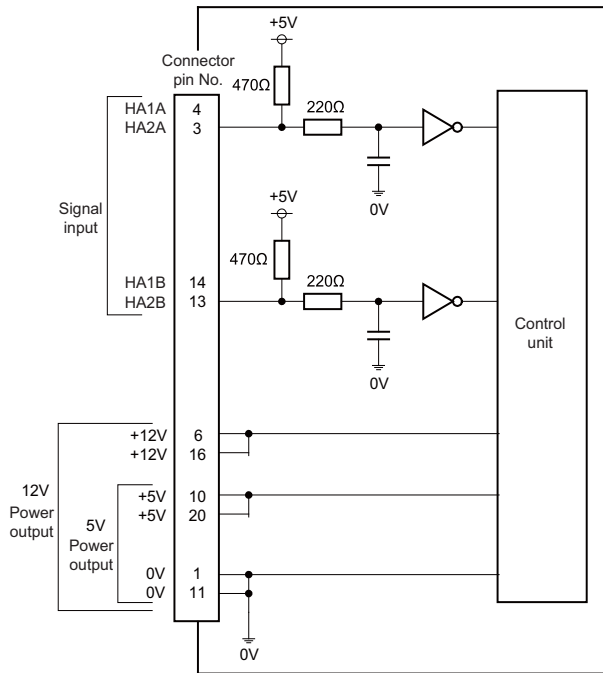

(11) Remote I/O unit I/F (RIO3)

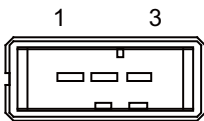

1	I/O	TXRX3
2	I/O	TXRX3*
3		0V(GND)

<Cable side connector type>

Connector: 1-178288-3

Contact: 1-175218-2 x3

Recommended manufacturer: Tyco Electronics

Refer to the following chart for the maximum number of connecting stations and I/O points.

Operation panel I/O unit type	Max. number of stations (RIO3 connection)	Max. number of I/O points (RIO3 connection)
FCU7-DX711	4 stations (stations 3rd to 6th can be used)	128 points/128 points
FCU7-DX621/DX721/DX731	3 stations (stations 4th to 6th can be used)	96 points/96 points

(Note) Refer to the section "General Specifications: Remote I/O Unit" for the number of occupying stations and I/O points of remote I/O units.

(12) Control unit I/F (CG71)

(13) LED

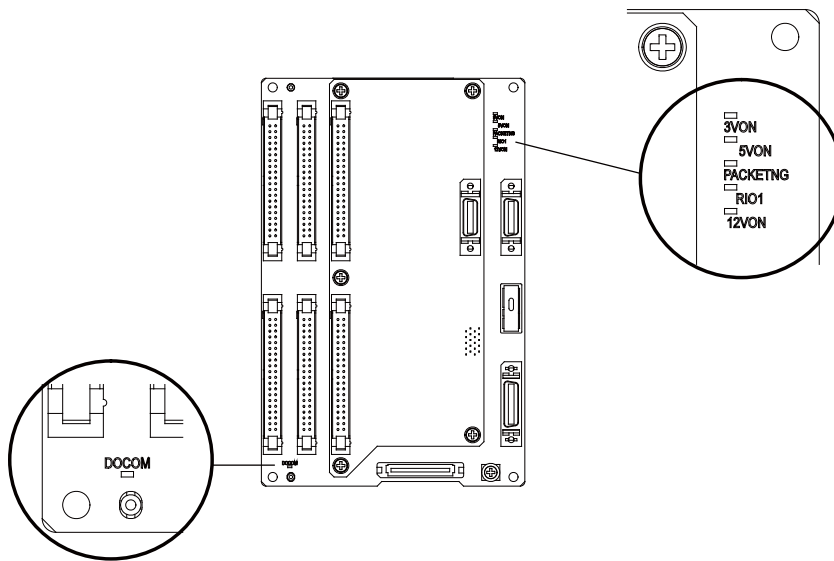

Name	Function	At fault	Conditions
3VON	3VDC input check	Not lit	(1) Disconnection between control unit and operation panel I/O unit
5VON	5VDC input check	Not lit	(1) Disconnection between control unit and operation panel I/O unit (2) Short circuit of manual pulse generator cable
PACKETNG	RIO communication status check	Lit (Red)	(1) Partial disconnection between control unit and operation panel I/O unit (2) Miswiring of extended I/O unit to RIO3
RIO1	RIO communication status check	Not lit	
12VON	For manual pulse generator	Not lit	Short circuit of manual pulse generator cable
DOCOM	24VDC input check	Not lit	(1) Disconnection of 24V input (2) Disconnection of protection fuse on the operation panel I/O unit

2.6 Remote I/O Unit

The following four types of signals can be input/output from the remote I/O unit (FCUA-DX1x1) according to the type and No. of contacts. Use serial link connections to connect the unit with the control unit or the operation panel I/O unit. Multiple remote I/O units can be used as long as the total number of occupied stations is eight or less.

Classification	Type	Components	Remarks
DI 24V/0V common input DO Source output	FCUA-DX101	RX312	DI: 32-points 24V/0V common type (photo coupler insulation) DO: 32-points source type (non-insulation) Number of occupied stations: 1
DI 24V/0V common input DO Source output	FCUA-DX111	RX312+RX322-1	DI: 64-points 24V/0V common type (photo coupler insulation) DO: 48-points source type (non-insulation) Number of occupied stations: 2
DI 24V/0V common input DO Source output AO Analog output	FCUA-DX121	RX312+RX322	DI: 64-points 24V/0V common type (photo coupler insulation) DO: 48-points source type (non-insulation) AO: 1 point Number of occupied stations: 2
DI 24V/0V common input DO Source output AI Analog input AO Analog output	FCUA-DX141	RX312+RX341	DI: 32-points 24V/0V common type (photo coupler insulation) DO: 32-points source type (non-insulation) AI: 4 points AO: 1 point Number of occupied stations: 2

Dimension and names of parts

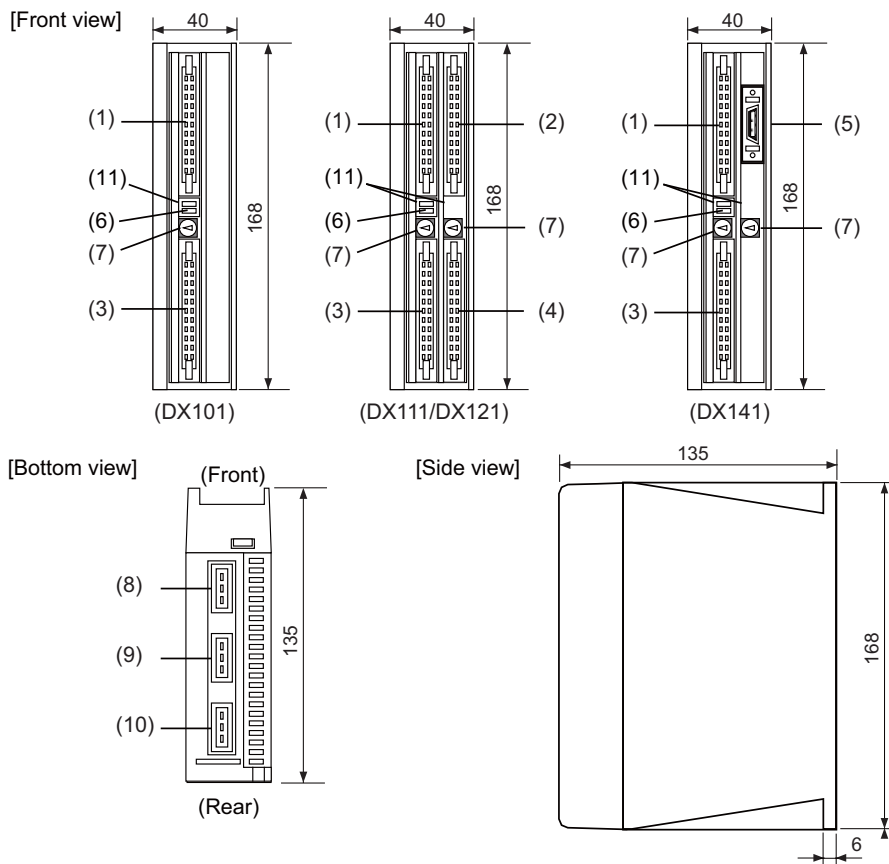

<Installation dimension drawing>

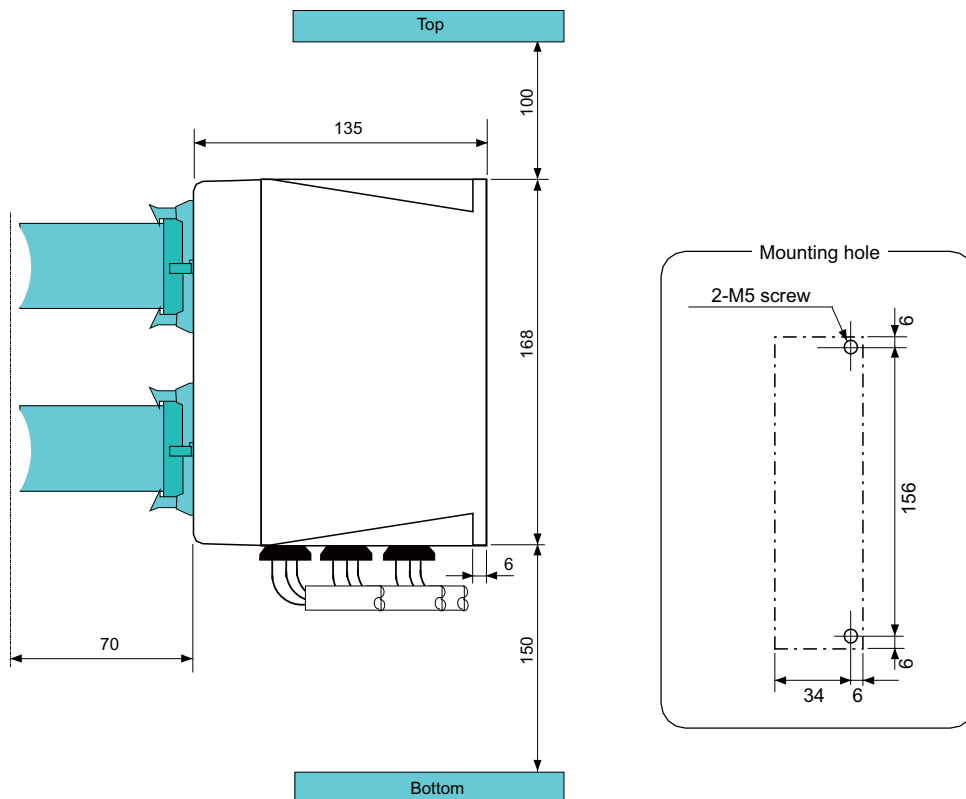

- (1) Machine input (DI-L)
- (2) Machine input (DI-R)

Both 24V common and 0V common connections are allowed in the digital signal input circuit. Follow the wiring diagram below for each type.

Input circuit

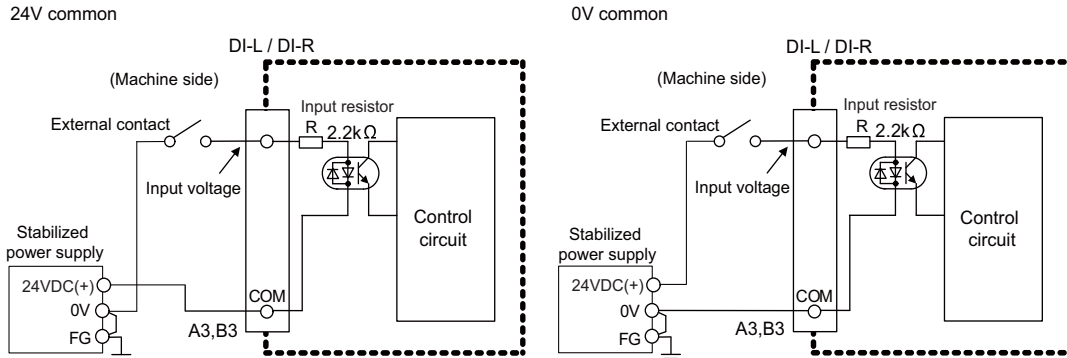

Input conditions

The input signals must be used within the following condition ranges.

		24V common	0V common
1	Input voltage at external contact ON	6V or less	18V or more, 25.2V or less
2	Input current at external contact ON	9mA or more	
3	Input voltage at external contact OFF	20V or more, 25.2V or less	4V or less
4	Input current at external contact OFF	2mA or less	
5	Input resistance	Approx. 2.2kΩ	
6	Tolerable chattering time (T1)	3ms	
7	Input signal holding time (T2)	40ms or more (Note)	
8	input circuit operation delay time (T3 and T4)	3 to 16ms	
9	Machine side contact capacity	30V or more, 16mA or more	

(Note) Input signal holding time: The guide is 40ms or more. The input signal will not be recognized unless it is held for the ladder processing cycle time or longer.

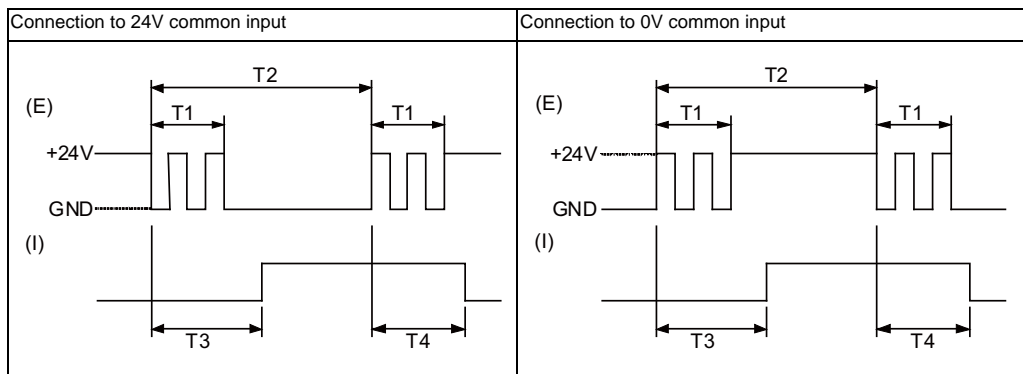

(E) : External signal, (I) : Internal signal

- (3) Machine output (DO-L)
- (4) Machine output (DO-R)

Use within the specification ranges shown below.

Output circuit

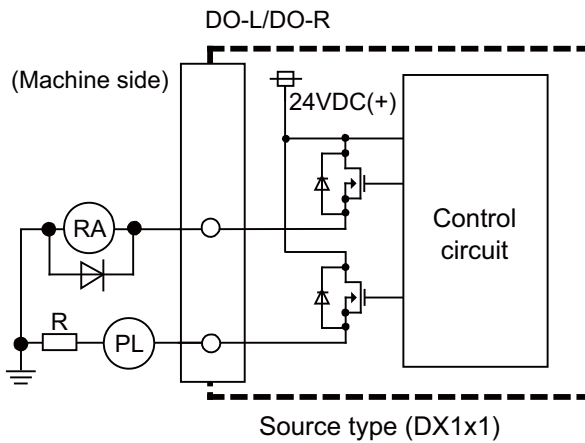

Output conditions

Insulation method	Non-insulation
Rated load voltage	24VDC
Max. output current	60mA/point
Output delay time	40μs

- (Note 1) When using an inductive load such as a relay, always connect a diode (voltage resistance 100V or more, 100mA or more) in parallel to the load.
- (Note 2) When using a capacitive load such as a lamp, always connect a protective resistor (R=150Ω) serially to the load to suppress rush currents. (Make sure that the current is less than the above tolerable current including the momentary current.)

[Outline of analog signal output circuit]

The analog signal output circuit can be used only for FCUA-DX121.

Output circuit

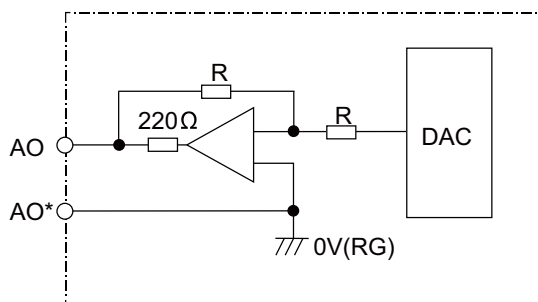

Output conditions

Output voltage	0V to ±10V (±5%)
Resolution	12bit (±10V × n/4096) (Note)
Load conditions	10kΩ load resistance
Output impedance	220Ω

(Note) $n=(2^0 \text{ to } 2^{11})$

⚠ CAUTION

1. When using an inductive load such as a relay, always connect a diode in parallel to the load.
2. When using a capacitive load such as a lamp, always connect a protective resistor serially to the load to suppress rush currents.

(5) Analog signal input/output (AIO)

(a) Outline of analog signal output circuit

The analog signal output circuit can be used only for FCUA-DX141.

Output circuit

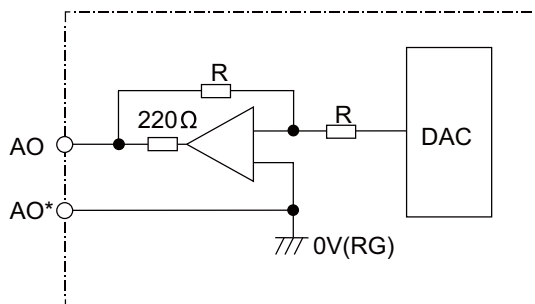

Output conditions

Output voltage	0V to ±10V (±5%)
Resolution	12bit (±10V × n/4096) (Note)
Load conditions	10kΩ load resistance
Output impedance	220Ω

(Note) $n=(2^0 \text{ to } 2^{11})$

(b) Outline of analog signal input circuit

The analog signal input circuit can be used only for FCUA-DX141.

Input circuit

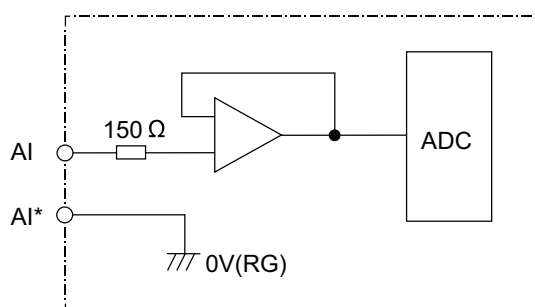

Input conditions

Max. input rating	±15V
Resolution	$ -10 \text{ to } +10\text{V} / 4096 = 4.88\text{mV}$
Precision	Within ±25mV
AD input sampling time	14.2ms(AI0)/ 42.6ms(AI1 to 3)

(6) Transfer speed changeover switch (DS)

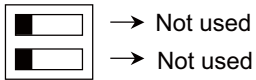

(7) Station No. changeover switch (CS)



(8) Remote I/O unit I/F #1 (RIO1)

(9) Remote I/O unit I/F #2 (RIO2)

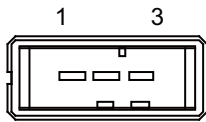

1	I/O	TXRX
2	I/O	TXRX*
3		0V

<Cable side connector type>

Connector: 1-178288-3

Contact: 1-175218-2 x3

Recommended manufacturer: Tyco Electronics

(10) 24VDC input (DCIN)

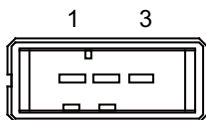

1	I	+24V
2		0V
3		FG

<Cable side connector type>

Connector: 2-178288-3

Contact: 1-175218-5 x3

Recommended manufacturer: Tyco Electronics

(11) LED

Name	Function	At fault	Conditions
POWER Green (UP)	Internal output voltage(5VDC) check	Not lit	(1) Failure of 24VDC input (2) Fuse is disconnected (3) Failure of internal voltage output in I/O unit
ALM Red (DOWN)	RIO communication status check	Lit	(1) Partial disconnection between control unit and remote I/O unit (2) Miswiring of connected remote I/O unit

2.7 External Power Supply Unit

Item	PD25
Input power voltage	200 to 230VAC +10%-15% 50/60Hz±1Hz
Output current	3A
Dimension	130mm × 65mm × 230mm
Mass	1.5kg
Output holding time	300ms

- (Note 1) PD25 will not be turned ON by the ON/OFF switch immediately after the power OFF. Wait at least 2 seconds, and then turn the power ON.
- (Note 2) The power supply configuration for NC devices depends on the machine. Appropriate circuit protector must be selected by machine builder according to the load of the machine.
- (Note 3) PD25 does not comply with 100VAC.

Dimension and names of parts [PD25]

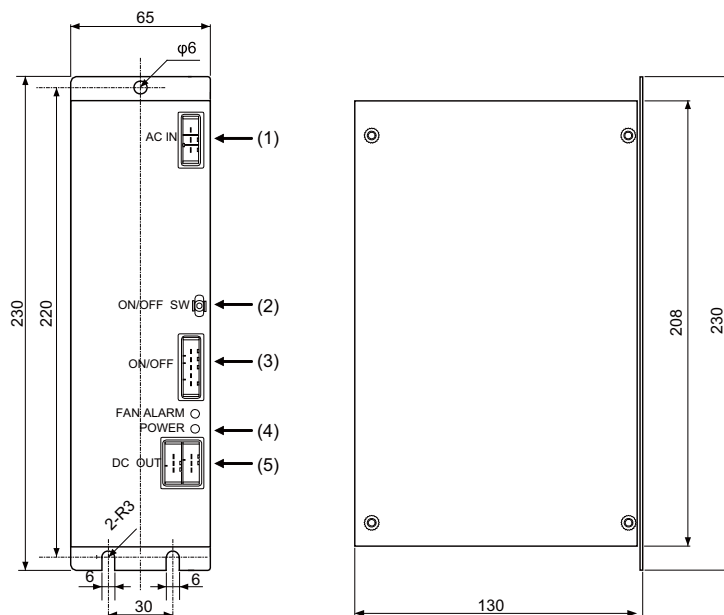

<Mounting direction and clearance>

Mount the external power supply unit vertically and so that it is visible from the front. Provide space for heat dissipation and ventilation.

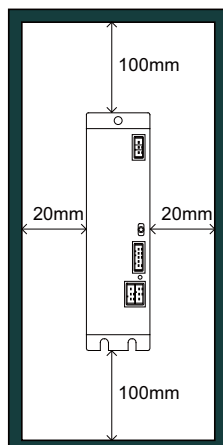

(1) AC power input (ACIN)

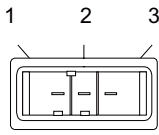

1	I	ACIN N
2	I	ACIN H
3		FG

<Cable side connector type>

Connector: 2-178128-3

Contact: 1-175218-5 x 3

Recommended manufacturer: Tyco Electronics

(2) ON/OFF switch (ON/OFF SW)

Switch ON (upward): 24VDC output

Switch OFF (downward): 24VDC output OFF

(3) ON/OFF input (ON/OFF)

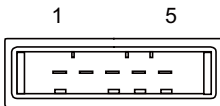

1		NC
2	I	P-OFF
3		0V
4		0V
5	I	P-ON

<Cable side connector type>

Connector: 1-178288-5

Contact: 1-175218-5 x 4

Recommended manufacturer: Tyco Electronics

(4) LED (POWER)

Green light at +24V output

(5) 24VDC output (DCOUT)

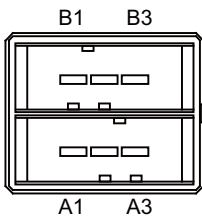

1A	O	ACFAIL	1B	O	+24V
2A		0V	2B		0V
3A		NC	3B		FG

<Cable side connector type>

Connector: 3-178127-6

Contact: 1-175218-5 (for AWG16) x 3, 1-175217-5 (for AWG22) x 2

Recommended manufacturer: Tyco Electronics

2.8 Manual Pulse Generator

[UFO-01-2Z9]

5V Manual Pulse Generator (100 pulse/rev)

<Outline dimension drawing>

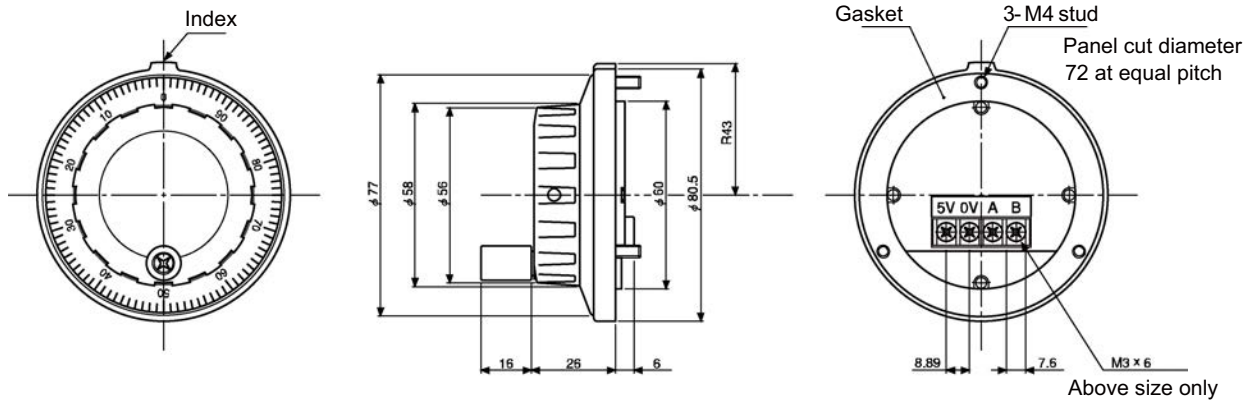

<Panel cut drawing>

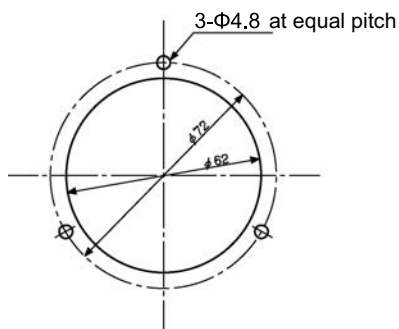

Produced by NIDEC NEMICON CORPORATION

2.9 Synchronous Feed Encoder

Dimension and names of parts

[OSE-1024-3-15-68]

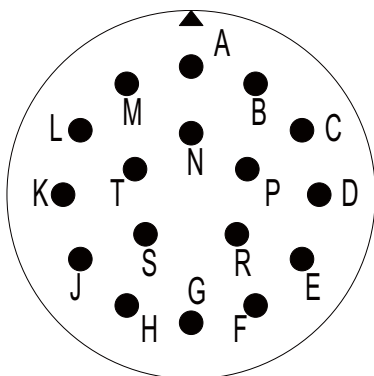
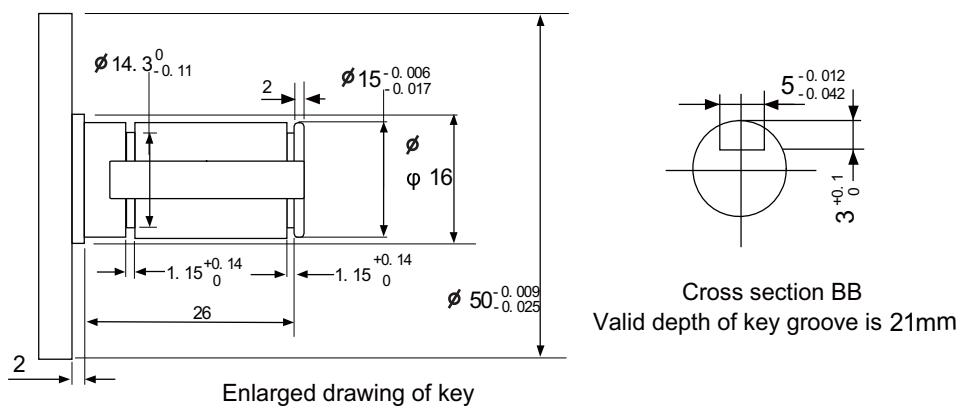
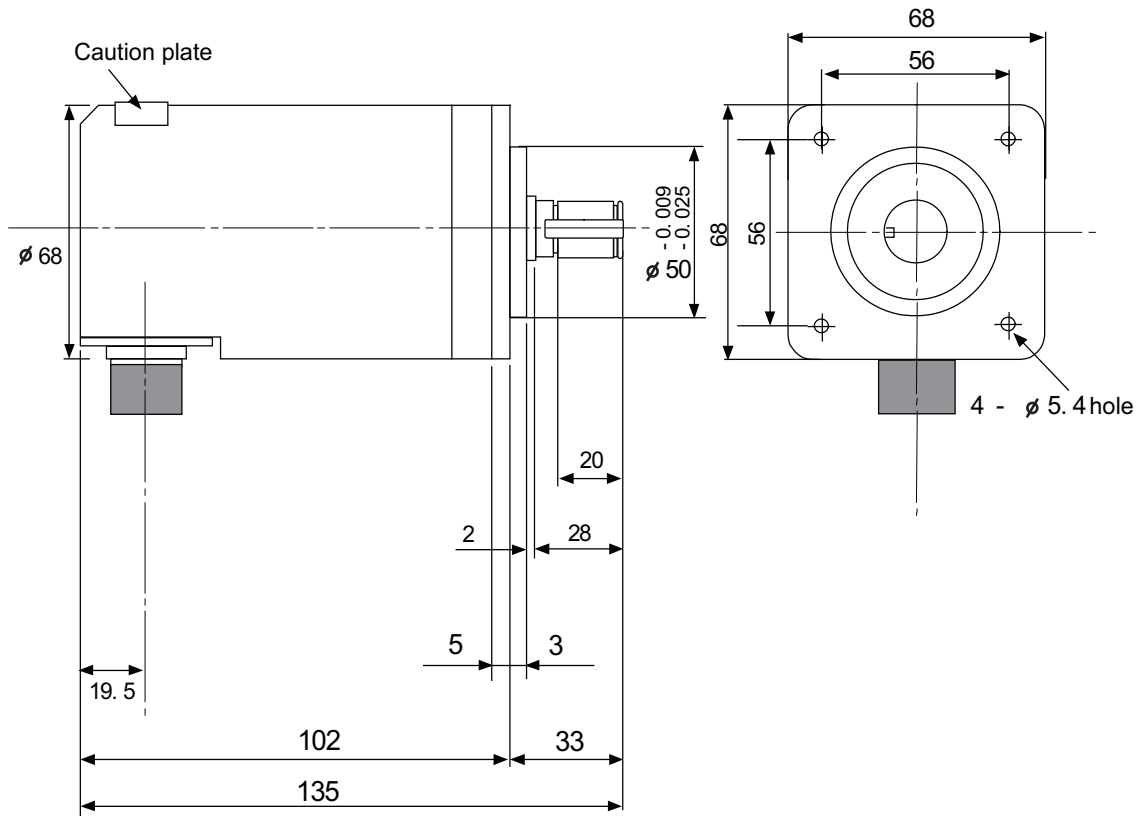

Connector pin assignment

Pin	Function	Pin	Function
A	A phase	K	0V
B	Z phase	L	-
C	B phase	M	-
D	-	N	A phase
E	Case grounding	P	Z phase
F	-	R	B phase
G	-	S	-
H	+5V	T	-
J	-		

2.10 MITSUBISHI CNC Machine Operation Panel

2.10.1 MITSUBISHI CNC Machine Operation Panel A

Outline dimension

[FCU7-KB921 (MITSUBISHI CNC machine operation panel A)]

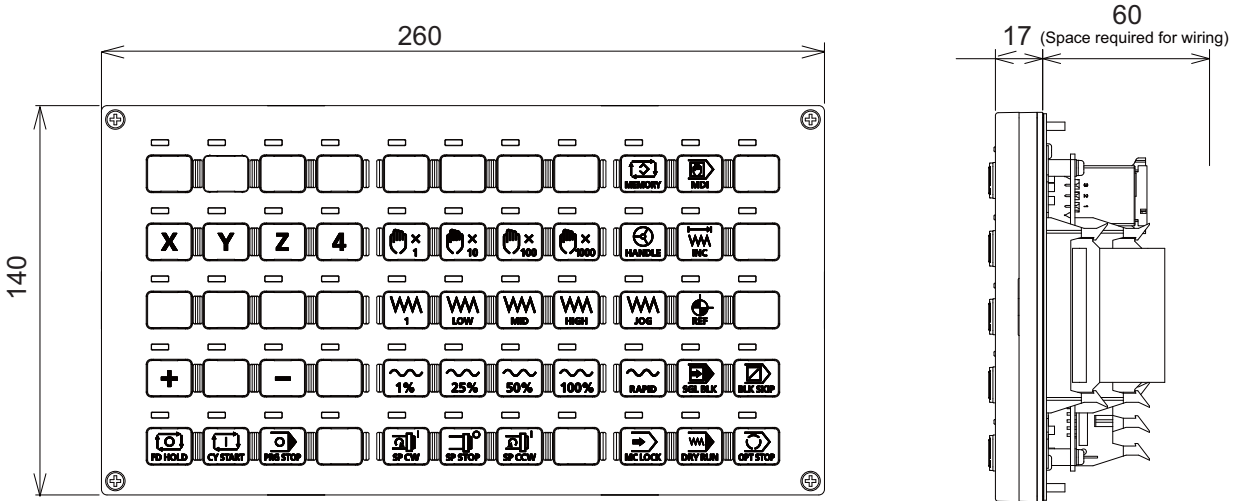

<Panel cut dimension drawing>

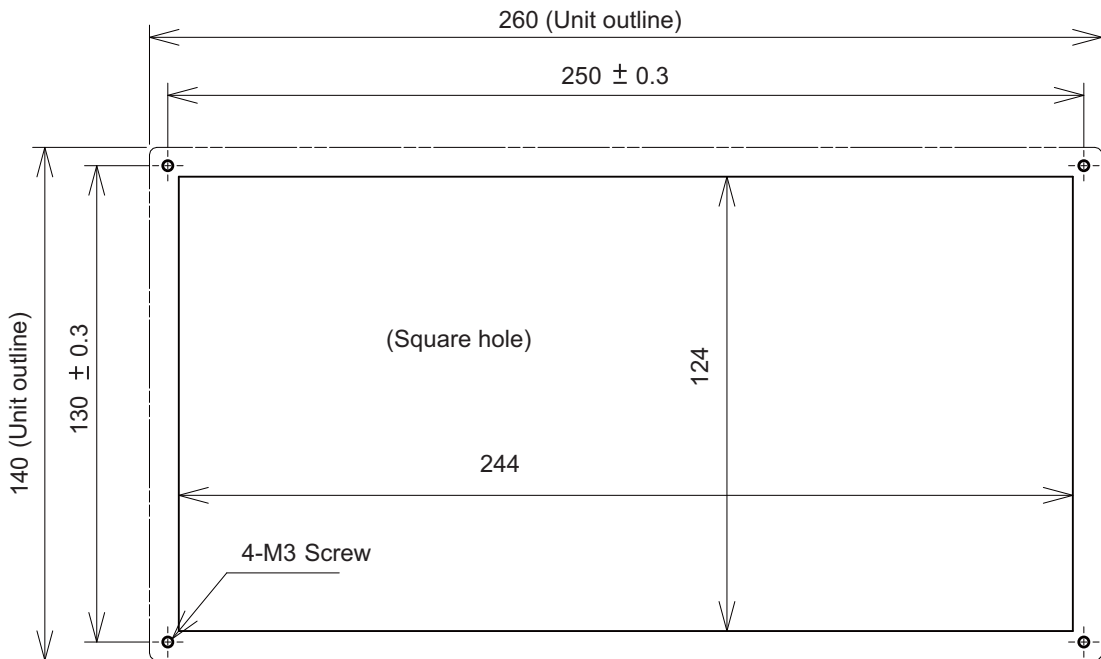

Connector

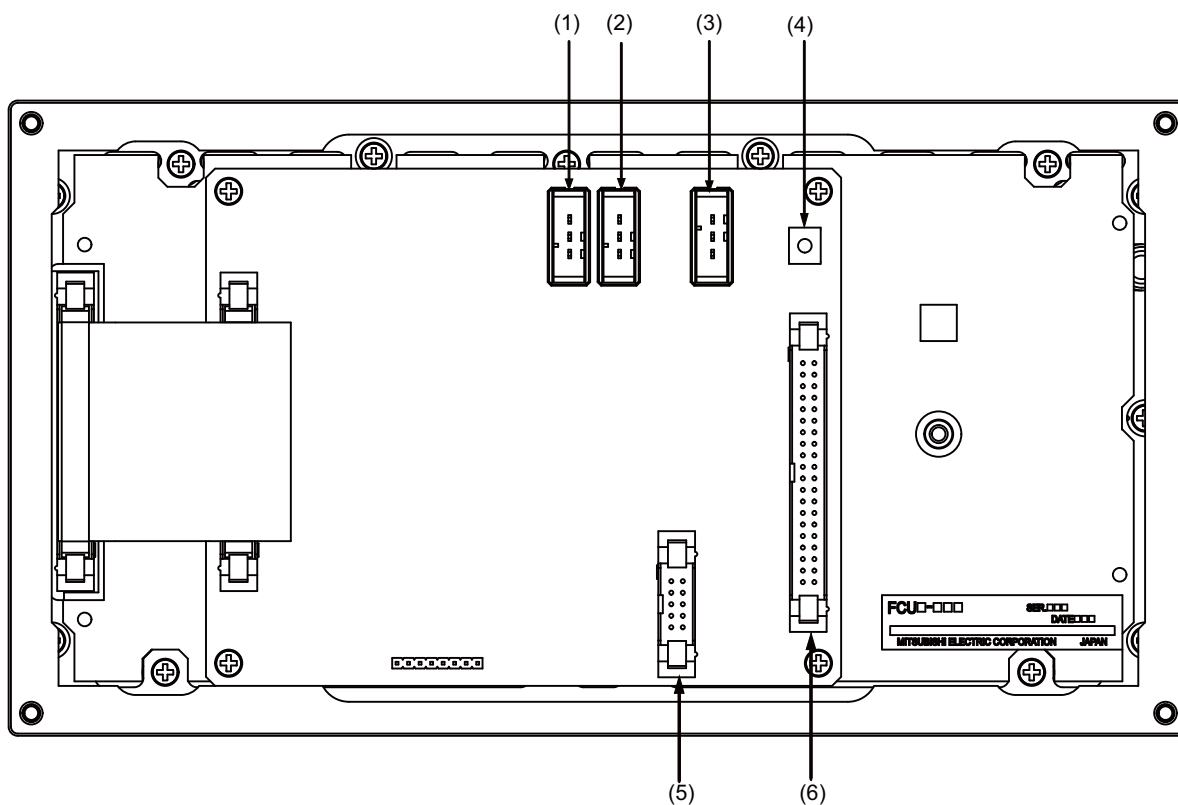

No.	Connector name	Function	No.	Connector name	Function
(1)	DCIN	24VDC input	(4)	FG	FG terminal
(2)	DCOUT	24VDC output	(5)	EXT	Relay wiring
(3)	RIOIN	Remote I/O	(6)	SUBP	Mahine operation panel B switch

(1)(2) 24VDC input/output (DCIN/DCOUT)

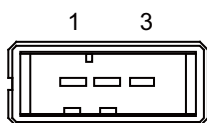

1	I/O	+24V
2	-	0V
3	-	FG

<Cable side connector type>

Connector: 2-178288-3

Contact: 1-175218-5 x3

Recommended manufacturer: Tyco Electronics

(3) Remote I/O connected connector (RIOIN)

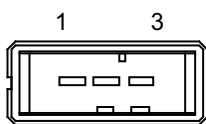

1	I/O	TXRX
2	I/O	TXRX*
3	-	0V

<Cable side connector type>

Connector: 1-178288-3

Contact: 1-175218-2 x3

Recommended manufacturer: Tyco Electronics

(4) FG terminal (FG)

(5) Relay wiring (EXT)

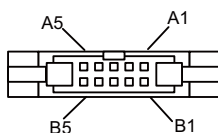

B05	-		A05	-	
B04	O	Relay EMGCOM	A04	O	Relay EMG
B03	O	Relay 6	A03	O	Relay 5
B02	O	Relay 4	A02	O	Relay 3
B01	O	Relay 2	A01	O	Relay 1

<Cable side connector type>

Connector: HIF3BA-10D-2.54C

Contact: HIF3-2428SC

Recommended manufacturer: Hirose Electric

(6) Machine operation panel B switch (SUBP)

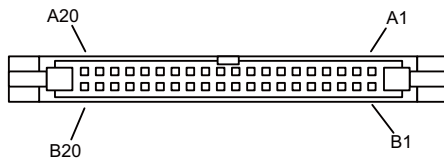

B20	I	Relay EMGCOM	A20	I	Relay EMG
B19	I	Relay 6	A19	I	Relay 5
B18	I	Relay 4	A18	I	Relay 3
B17	I	Relay 2	A17	I	Relay 1
B16	-	0V	A16	I	Spare SW(X75)
B15	-	0V	A15	I	Spare SW(X74)
B14	-	0V	A14	I	Spare SW(X73)
B13	-	0V	A13	I	Selector SW(X72)
B12	-		A12	I	G(X71)
B11	I	F(X6D)	A11	I	E(X6F)
B10	I	D(0V)	A10	I	C(X70)
B09	I	B(X6E)	A09	I	A(X6C)
B08	-		A08	I	G(X6B)
B07	I	F(X67)	A07	I	E(X66)
B06	I	D(0V)	A06	I	C(X6A)
B05	I	B(X68)	A05	I	A(X66)
B04	-		A04	I	G(X65)
B03	I	F(X61)	A03	I	E(X63)
B02	I	D(0V)	A02	I	C(X64)
B01	I	B(X62)	A01	I	A(X60)

<Cable side connector type>

Connector: HIF3BA-40D-2.54C

Contact: HIF3-2428SC

Recommended manufacturer: Hirose Electric

(a) Wiring of machine operation panel B

<Wiring of rotary switch (SUBP)>

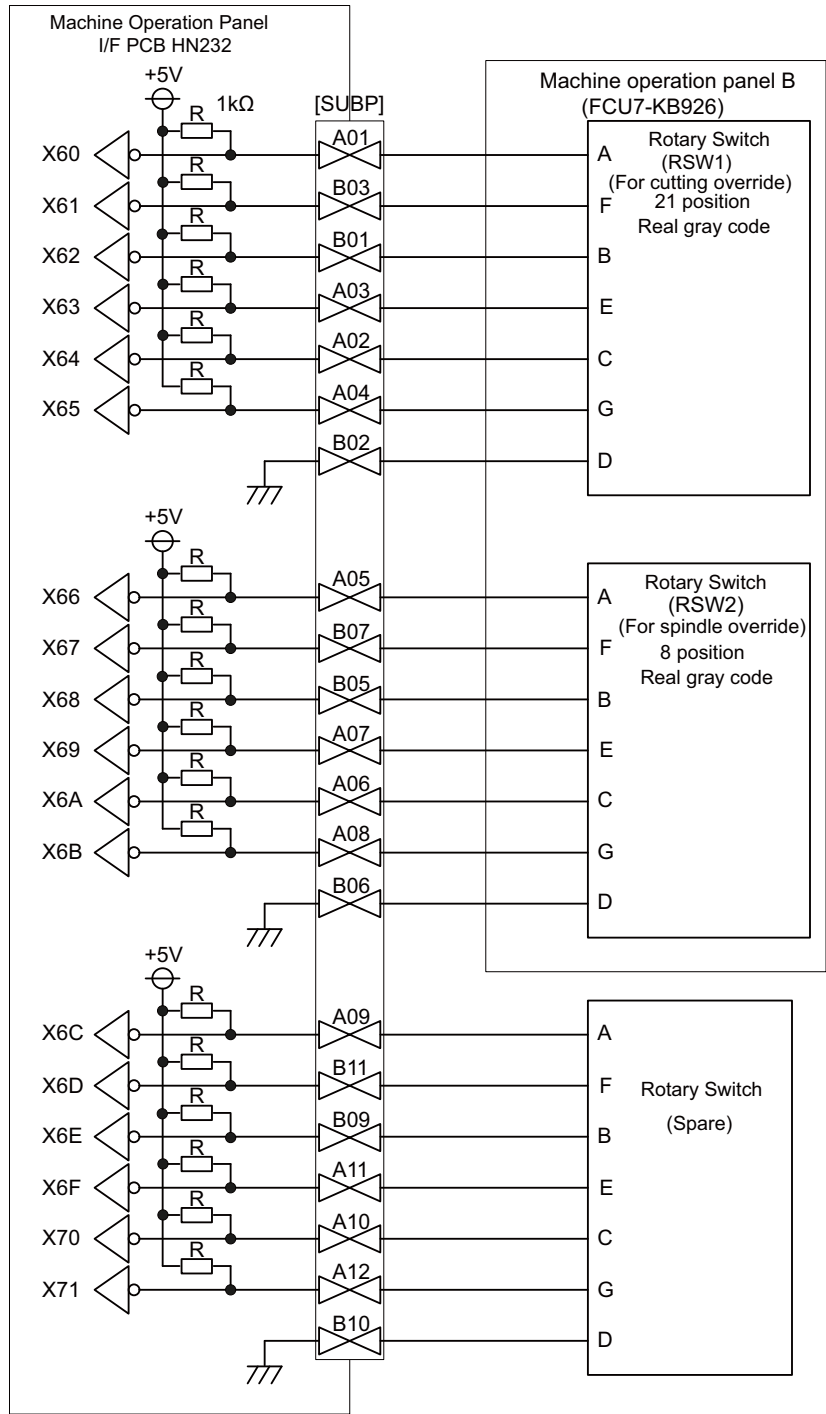

- (Note1) Use the special lead wire with a connector for wiring of rotary switch.
Lead wire with a connector: ACX011-705 (7 terminals, 0.5m) Fuji Electric
- (Note2) A09 to 12 and B09 to 11 of SUBP are spares, so they do not need wiring.
- (Note3) Select a rotary switch which guarantees 5V/1mA.
- (Note4) Length of cables must be 0.5m or shorter.
- (Note5) The numbers in the above diagram do not indicate the actual device numbers.

<Wiring of other switches (SUBP)>

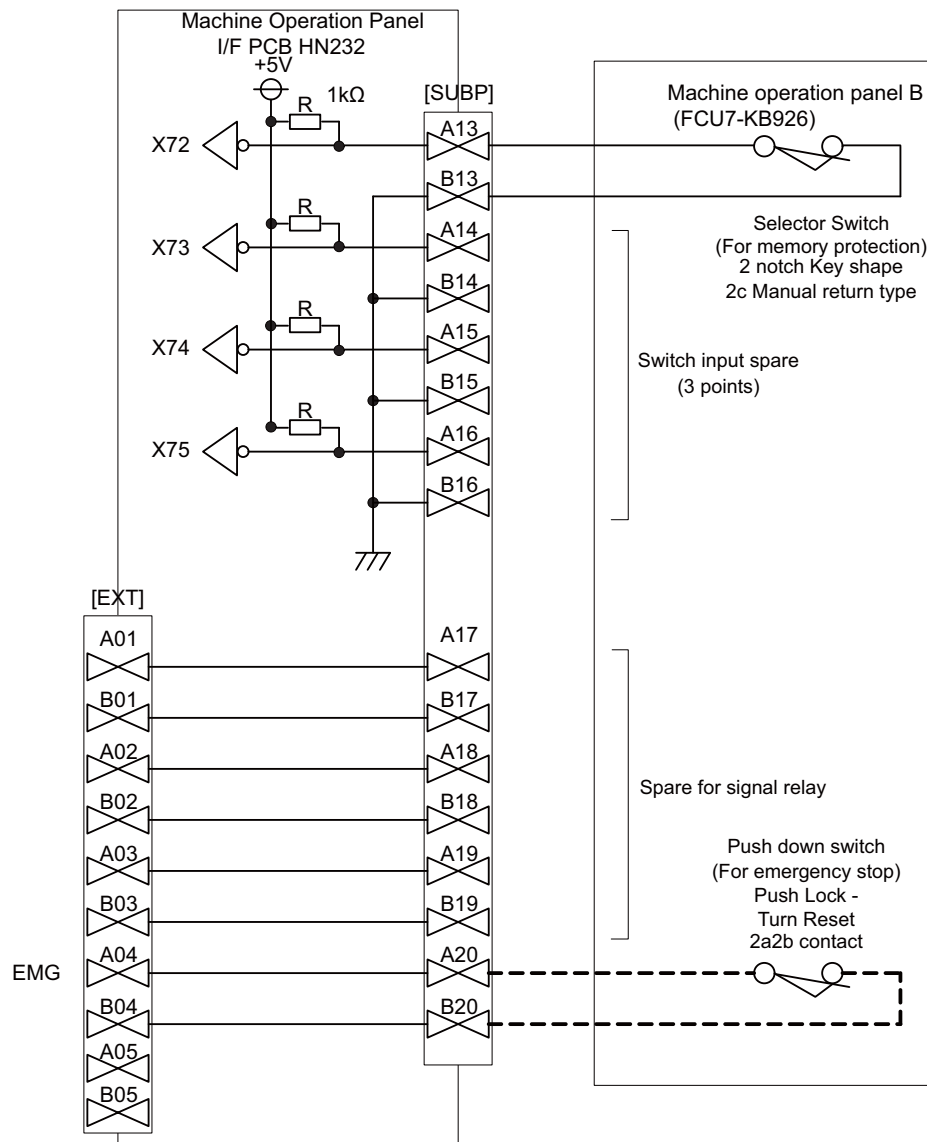

- (Note1) Wirings for selector switches must be directly soldered to terminals or use tab terminals (110 series).
- (Note2) When wiring the emergency stop switch, the crimp terminal must be fastened with thread.
- (Note3) For NCs whose control unit and display unit are integrated, wire the emergency stop switch directly to the EMG connector of the control unit. (Use F120 cable)
 And for NCs whose control unit and display are separated, relay it by the machine operation panel I/F PCB HN232.
- (Note4) Select a rotary switch which guarantees 5V/1mA.
- (Note5) Length of cables must be 0.5m or shorter.
- (Note6) The numbers in the above diagram do not indicate the actual device numbers.

<Connection when the selector SW has 3 notches>

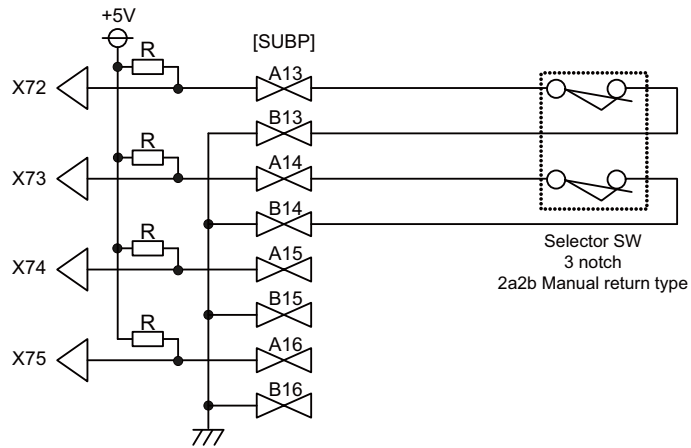

<Connection when relaying wiring to control panel>

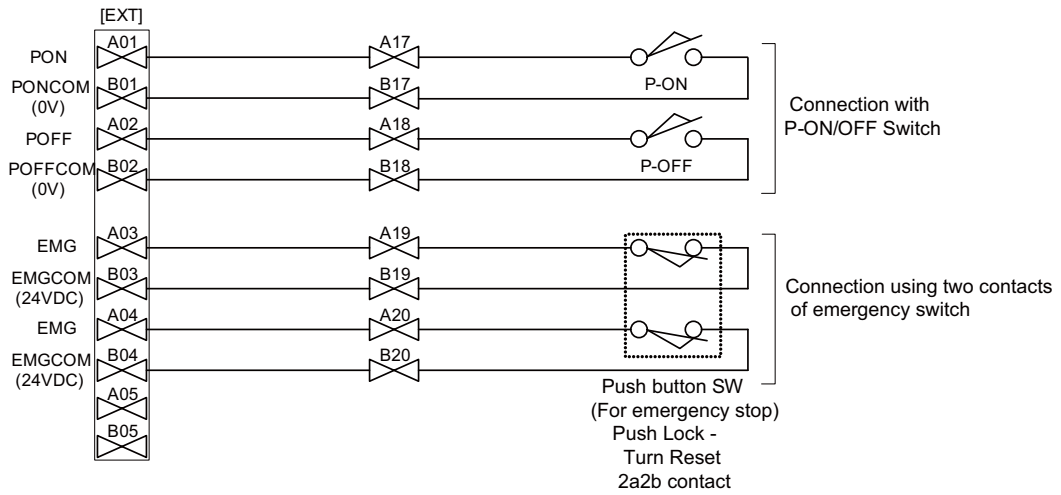

2.10.2 MITSUBISHI CNC Machine Operation Panel B

Outline dimension

[FCU7-KB926 (MITSUBISHI CNC machine operation panel B)]

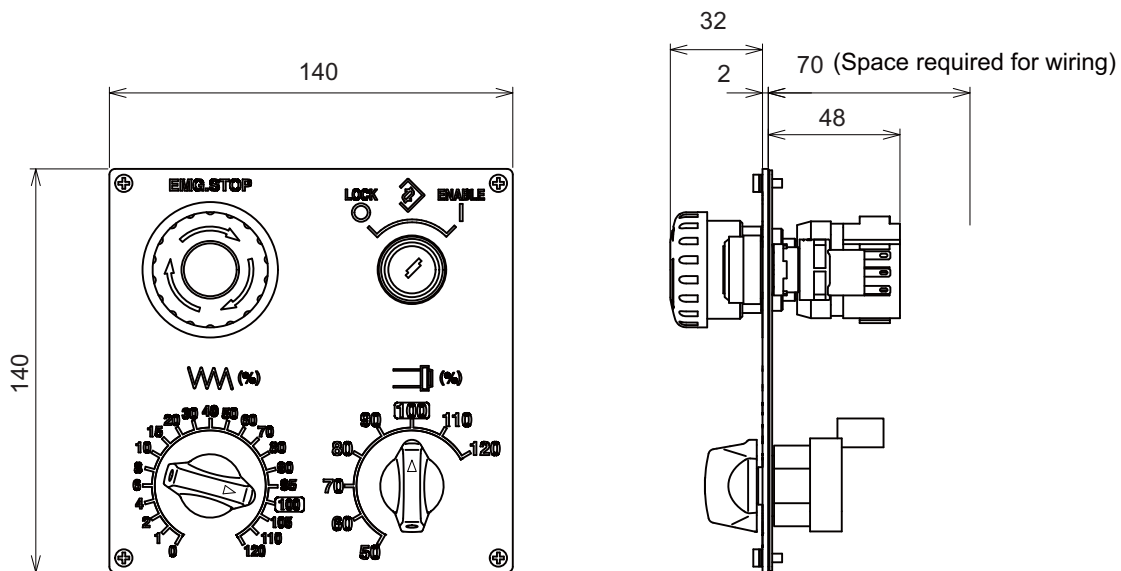

<Panel cut drawing>

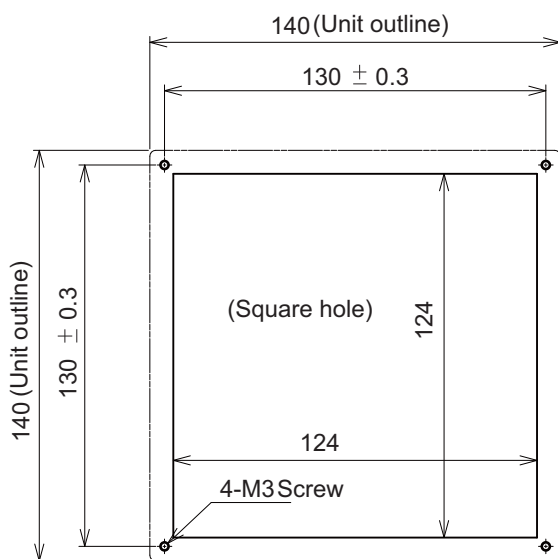

Connector

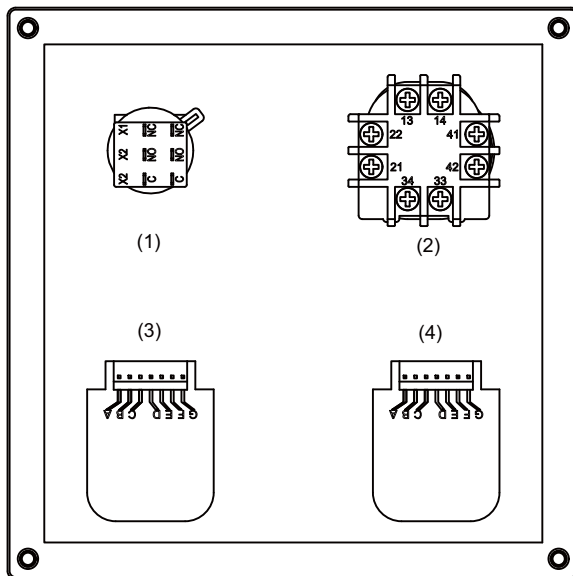

No.	Switch	No.	Switch
(1)	Memory protection switch	(3)	Spindle override (RSW2)
(2)	Emergency stop button	(4)	Cutting override (RSW1)

(1) Memory protection switch

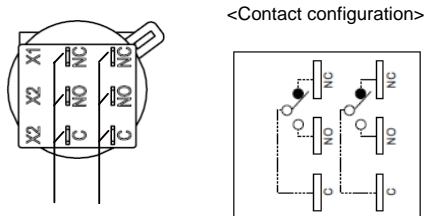

Contact 2 Contact 1

C	-	Contact 1(Common)
NO	O	Contact 1(A contact)
NC	O	Contact 1(B contact)
C	-	Contact 2(Common)
NO	O	Contact 2(A contact)
NC	O	Contact 2(B contact)

<Switch type>

Switch: HA1K-2C2B

Recommended manufacturer: IDEC

Connection: Terminal (#110 type)

(2) Emergency stop button

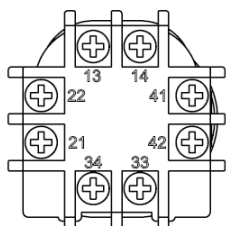

13	O	Contact 1(A contact)
14	O	Contact 1(A contact)
21	O	Contact 2(B contact)
22	O	Contact 2(B contact)
33	O	Contact 3(A contact)
34	O	Contact 3(A contact)
41	O	Contact 4(B contact)
42	O	Contact 4(B contact)

<Switch type>

Switch: XA1E-BV422MR

Recommended manufacturer: IDEC

Connection: Thread terminal (M3)

(3) Spindle override (RSW2)

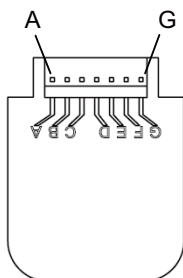

A	O	Output signal 1
B	O	Output signal 3
C	O	Output signal 5
D	-	Common terminal
E	O	Output signal 4
F	O	Output signal 2
G	-	-

<Switch type>

Switch: AC09-GX0/7L3B02

Recommended manufacturer: Fuji Electric

Connection: Connector

<Switch side connector type>

Connector: IL-7P-S3EN2

Recommended manufacturer: Japan Aviation Electronics

<Cable side connector type>

Connector: IL-7S-S3L-(N)

Contact: L-C2-10000

Recommended manufacturer: Japan Aviation Electronics

(4) Cutting override (RSW1)

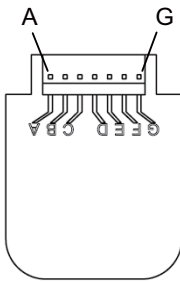

A	○	Output signal 1
B	○	Output signal 3
C	○	Output signal 5
D	-	Common terminal
E	○	Output signal 4
F	○	Output signal 2
G	○	Output signal 6

<Switch type>

Switch: AC09-GY0/20L3B02

Recommended manufacturer: Fuji Electric

Connection: Connector

<Switch side connector type>

Connector: IL-7P-S3EN2

Recommended manufacturer: Japan Aviation Electronics

<Cable side connector type>

Connector: IL-7S-S3L-(N)

Contact: IL-C2-10000

Recommended manufacturer: Japan Aviation Electronics

2.11 Exclusive CF Cards for MITSUBISHI CNC

Item	FCU7-CF256M	FCU7-CF002G
Capacity	256MB	2GB
Operation-guaranteed temperature	-40 °C to +85 °C	
NAND Flash	SLC (Note)	

(Note) SLC stands for Single Level Cell, and it stores one bit data in each memory cell. This provides longer life span and high product reliability in comparison with MLC (Multi Level Cell), which is commonly applied to CF cards.

2.11.1 Precautions for Use of Commercially Available CF Cards

Mitsubishi is unable to guarantee the machine operation when a commercially available CF card or SD memory card (SD-CF adapter is required) is used. In that case, performance check must be made carefully by machine tool builder.

- (1) Commercially available CF cards may not be compatible with MITSUBISHI units or suitable FA environment for temperature- or noise-wise. In case of using it, careful performance check must be required by the machine tool builder.
- (2) When inserting/removing a commercially available CF card, turn the MITSUBISHI device's power OFF to avoid any troubles. If a card must be inserted and removed while the power is ON, make sure to take sufficient time (approx. ten seconds or more) between the insertion and removal.
- (3) Do not pull out the card or turn OFF the power during access to the CF card. Failure to observe this could cause the memory contents to be erased. In case of emergency, always perform backups by having your important data duplicated, etc. as MITSUBISHI will not guarantee the broken or lost data.



Installation

3.1 Heat Radiation Countermeasures

Please refer to the following method for heat radiation countermeasures.

Example of heat radiation countermeasures

<Hypothetical conditions>

- (1) Average internal temperature of operation panel: $T \leq 55^{\circ}\text{C}$
- (2) Peripheral temperature of operation panel : $T_a \leq 0^{\circ}\text{C}$ to 45°C
- (3) Internal temperature rise value : $\Delta T = T - T_a$ (max) = 10°C

Procedures for heat design and verification

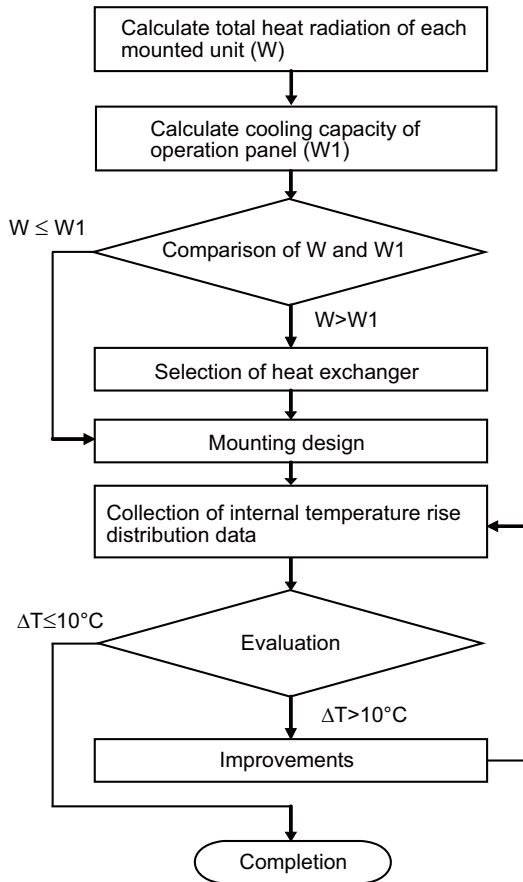

<Supplement>

- (1) Refer to "General Specification" for the heat generated by each unit.
- (2) Enclosed cabinet (thin steel plate) cooling capacity calculation equation

$$W1 = U \times A \times \Delta T$$
 U: $6 \text{ W/m}^2\text{°C}$
 A: Effective heat radiation area (m^2) (Area where heat can be radiated from operation panel)
 ΔT: Internal temperature rise value (10°C)
 (Caution) $8 \text{ W/m}^2\text{°C}$ can be applied only when the operation panel is so small that the internal temperature stays uniform.
- (3) Points of caution for heat radiation countermeasures when designing mounting state
 - Consider convection in operation panel (eliminate heat spots)
 - Collect hot air at suction port of heat exchanger in operation panel.
- (4) Criterion for internal temperature rise distribution data
 - ΔT (average value) $\leq 10^{\circ}\text{C}$
 - ΔTmax (maximum value) $\leq 15^{\circ}\text{C}$
 - R (inconsistency $\Delta T_{\text{max}} - \Delta T_{\text{min}}$) $\leq 6^{\circ}\text{C}$
 - (Evaluate existence of heat spots)

The following shows an example of calculation applied to heat radiation countermeasures for the operation panel when 8.4-type display unit is used. Because heat will accumulate in the upper portions of the unit, install an agitating fan as required.

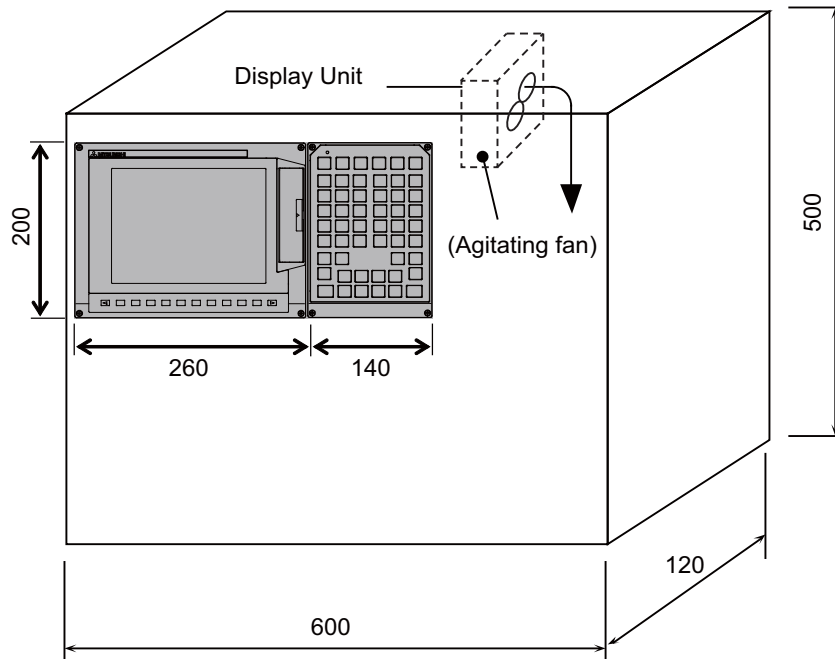

Calculation example of panel internal heating value

(1) Calculation of unit heating value

Heating value (W)

Total heating value of units (W):

28W (= control unit + display unit + keyboard unit + operation panel I/O unit)

Total heating value (W) by machine input (D1):

5.6W (=24V (total heating value when the 32 points are simultaneously turned ON) × 7.3mA × 32)

... 24V (current consumption per point of the operation panel I/O unit DI) divided by 3.3kΩ ≈ 7.3mA

Total heating value W = 33.6W (28 + 5.6)

(2) Calculation of operation panel cooling capacity

Tolerance value for temperature rise (Δt)

Panel internal temperature (according to each unit's specification) T ≤ 55C°

Panel peripheral temperature (according to machine's specification) Ta ≤ 45C°

Tolerance value for internal temperature rise ΔT = 10C° (T - Ta)

Heat radiation area (A)

The surface of the molded unit, which has lower radiation capacity than the base plate surface, should be excluded for the heat radiation area in principle. The bottom of the operation panel, which has difficulty in radiating due to the temperature distribution, should also be excluded for the heat radiation area in principle.

Heat radiation area A = 0.71mm²

(≈ 0.6 × 0.12 + 0.6 × 0.5 × 2 - (0.26 + 0.14) × 0.2 + 0.12 × 0.5 × 2)
 (Top surface) (Front, rear surface) (Unit surface) (Both sides surface)

Operation panel cooling capacity (W1)

Calculate the cooling capacity to keep the temperature rise in the operation panel less than 10°C.

Cooling capacity W1 = 42.6W (6 × A × ΔT)

(3) Comparison of heating value and operation panel cooling capacity

The operation panel cooling capacity is over the heating value, which presumed no need to install the heat exchanger.

(4) Confirmation with the actual machine

The result of the calculation above is only a rough indication. The actual temperature rise may differ according to the structure of the operation panel. Be sure to confirm the temperature rise value in the operation panel when the machine is running.

3.2 Noise Countermeasures

3.2.1 Connection of FG (Frame Ground)

The frame should basically be grounded at one ground point.

Connect the control unit and operation panel I/O unit's 0V (RG) to the FG on the +24V stabilized power supply.

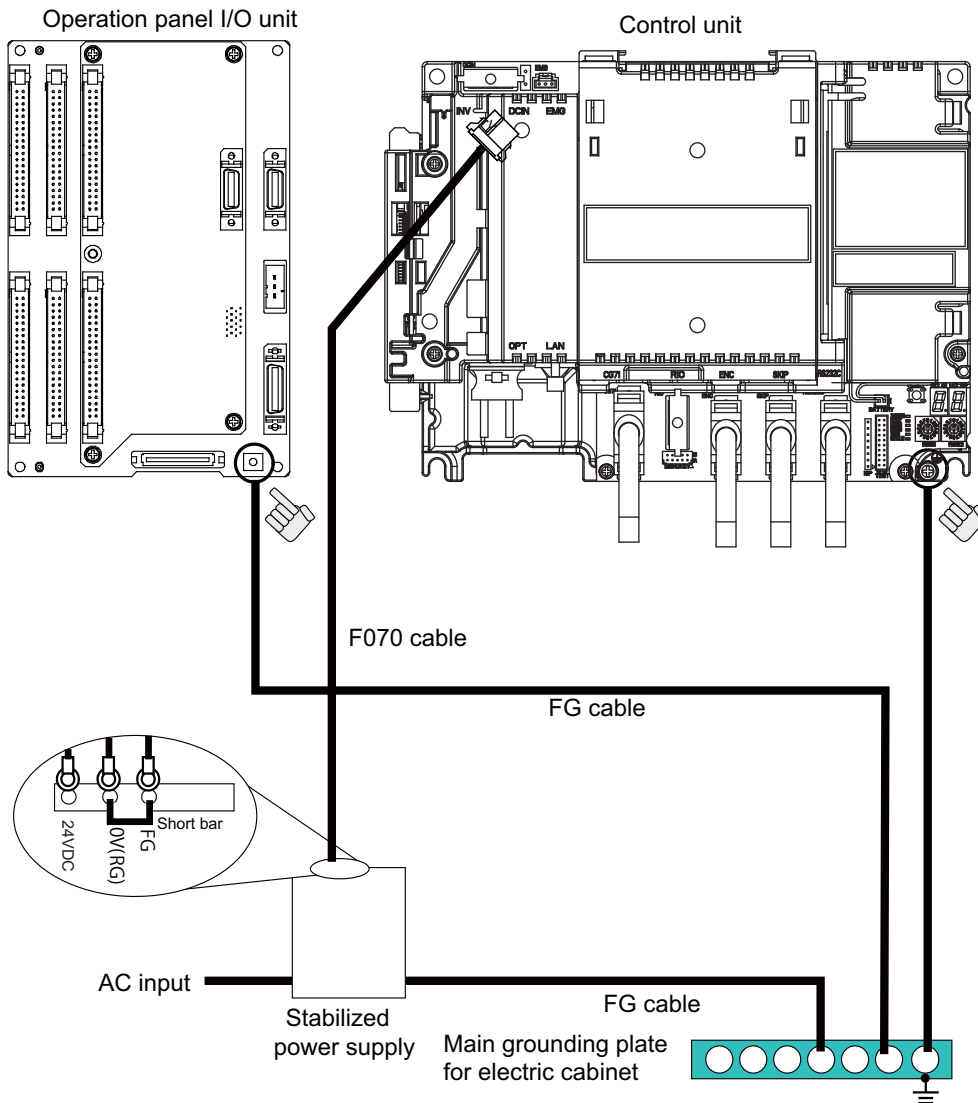

(Note) "24VDC" represents (+) side of 24V stabilized power supply, while "0V(RG)" represents (-) side. "FG" (Frame Ground) corresponds to the general expression "PE" (Protective Earth).

3.2.2 Shield Clamping of Cables

The shield cables connected to the units must be properly connected to the ground with clamp fittings and the like in order to stabilize the system's operation while preventing malfunctioning due to exogenous noise. (Refer to "EMC Installation Guidelines: EMC Countermeasure Parts: Shield Clamp Fitting".)

3.2.3 Connecting Spark Killers

Connect a spark killer on the coil or the contact in parallel for noise countermeasures.

Use spark killers which are 0.33 to 0.1 μ F, 10 to 120 Ω .

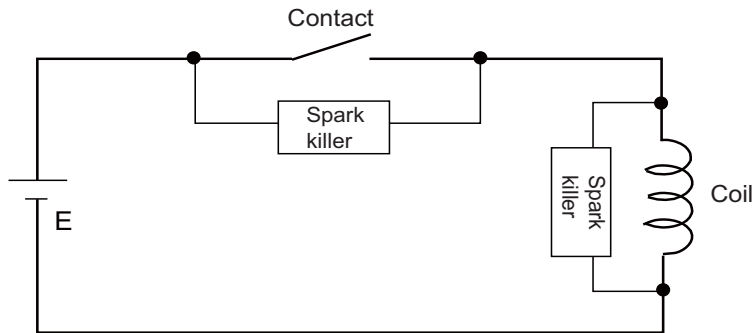

3.3 Unit Installation

3.3.1 Display Unit

Mount the display unit with four fixing screws.

(Note) Refer to "General Specifications: Display Unit" for the panel cut dimension drawing and the screw hole position.

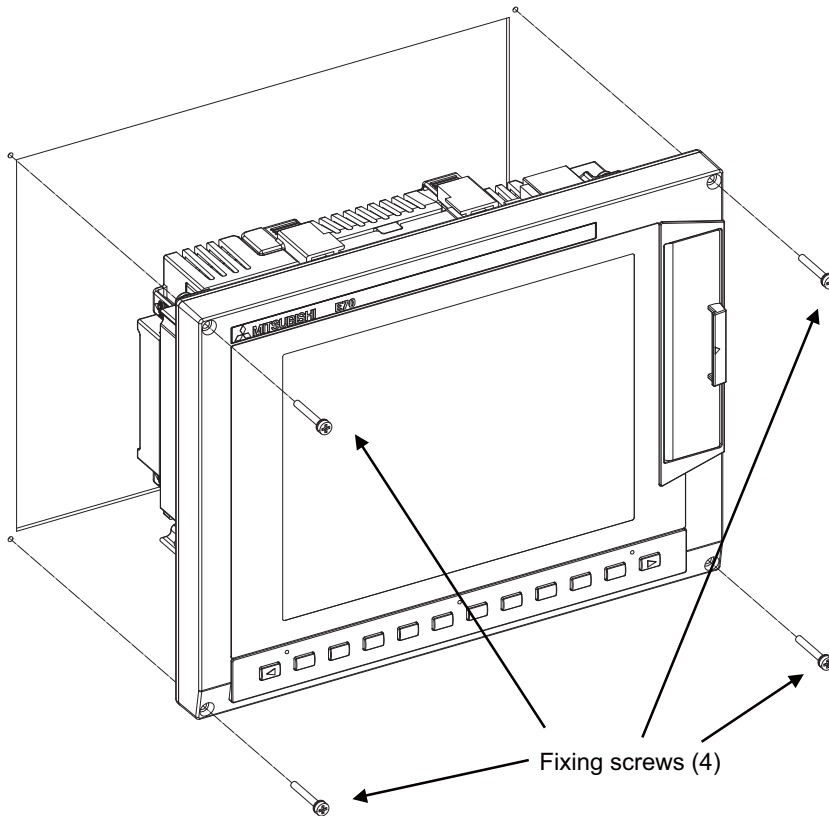

3.3.2 Keyboard Unit

Mount the keyboard unit with four fixing screws.

(Note 1) Refer to "General Specifications: Keyboard Unit" for the panel cut dimension drawing and the screw hole position.

(Note 2) A clear protective film covers the sheet keys of the keyboard at the time of shipment. Make sure to remove the sheet before use.

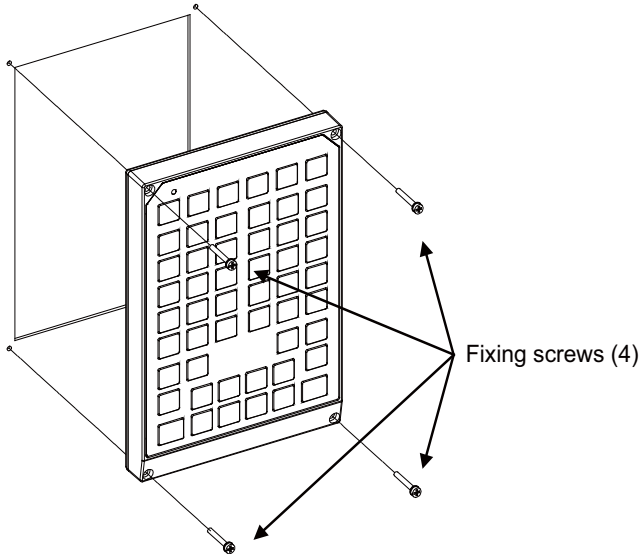

3.3.3 Operation Panel I/O Unit

Mount the operation panel I/O unit on the back of the keyboard unit with four fixing screws.

(Note) The operation panel I/O unit is usually mounted on the keyboard unit when shipped.

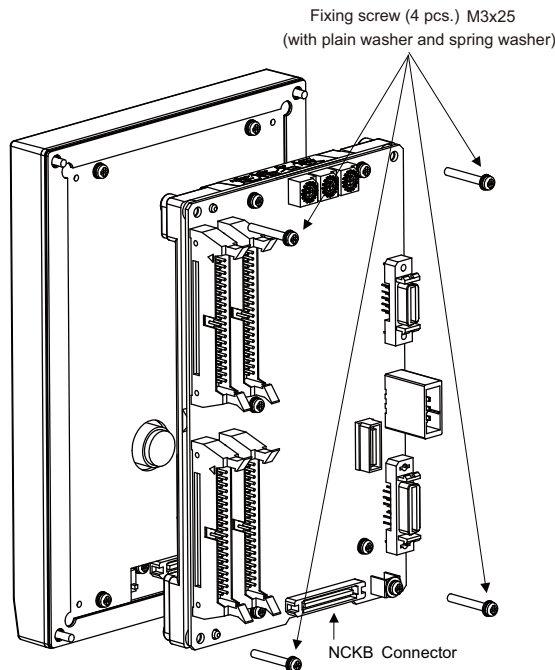

3.3.4 Control Unit Battery

A lithium battery in the control unit battery holder retains parameter settings, machining programs and the like, which requires to be backed up at the power OFF.

Battery	Q6BAT
Battery cumulative data holding time	45,000 hours (At 0 to 45°C. The life will be shorter if the temperature is high.)
Battery life	Approx. 5 years (from date of battery manufacture)

[Installation method]

- (1) Check that the machine power is turned OFF. (If the power is not OFF, turn it OFF.)
- (2) Confirm that the control unit LED, 7-segment display, etc., are all OFF.
- (3) Open the battery cover of the control unit. Pull the right side of the battery cover toward front.
- (4) Fit the new battery into the battery holder.
- (5) Insert the connector connected to the new battery into the BAT connector. Pay attention to the connector orientation: do not insert backwards.
- (6) Close the front cover of the control unit. At this time, confirm that the cover is closed by listening for the "click" sound when the latch catches.

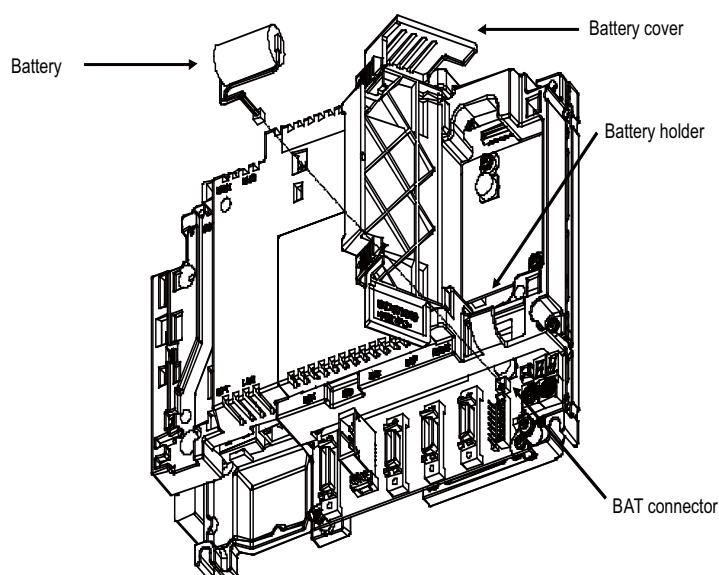

[Precautions for handling battery]

- (1) Do not disassemble the battery.
- (2) Do not place the battery in flames or water.
- (3) Do not pressurize and deform the battery.
- (4) This is a primary battery so do not charge it.

⚠ CAUTION

Do not short circuit, charge, overheat, incinerate or disassemble the battery.



4

Connection

4.1 Precautions for Wiring

4.1.1 Precautions when Connecting/Disconnecting Cables

If the cable is connected/disconnected without turning the power OFF, the normal unit or peripheral devices could be damaged, and risks could be imposed.

Disconnect each cable with the following procedures.

- (a) For the following type of connector, press the tabs with a thumb and forefinger in the direction of the arrow, and pull the connector off.

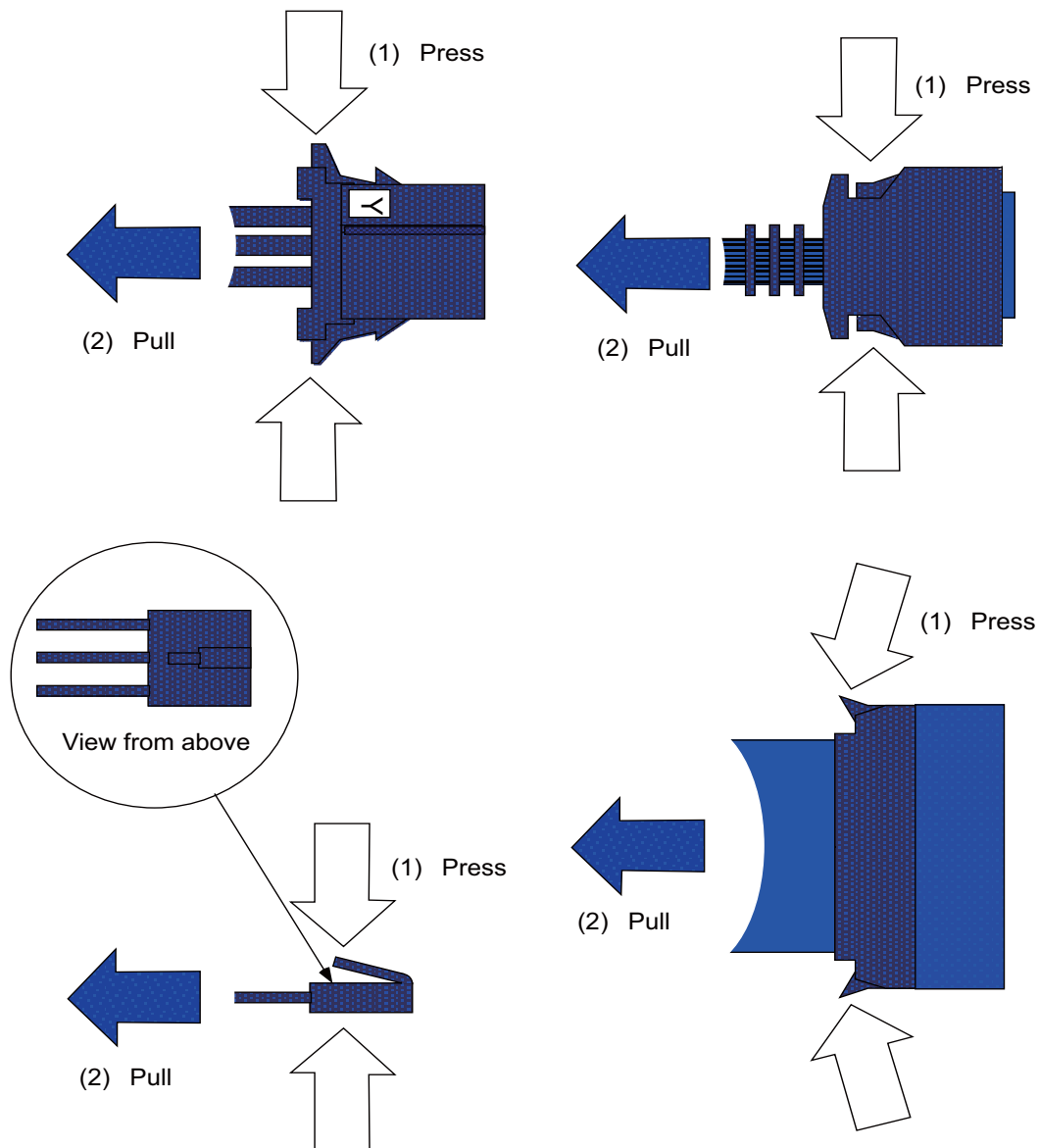

⚠ CAUTION

1. Do not connect or disconnect the cables between units while the power is ON.
2. Do not pull the cables when connecting/disconnecting it.

- (b) For a flat cable type connector with latches, open the latches in the directions of the arrows, and pull the connector off.

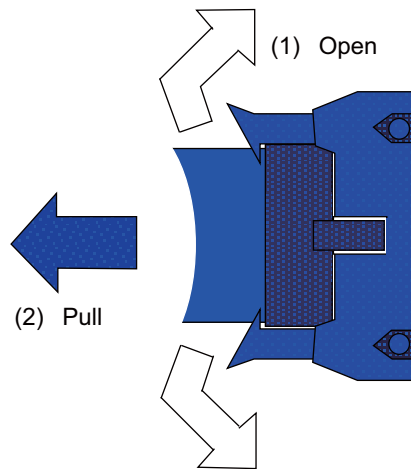

- (c) For a flat cable type connector without latches, hold the connector with a thumb and forefinger, and pull the connector off.

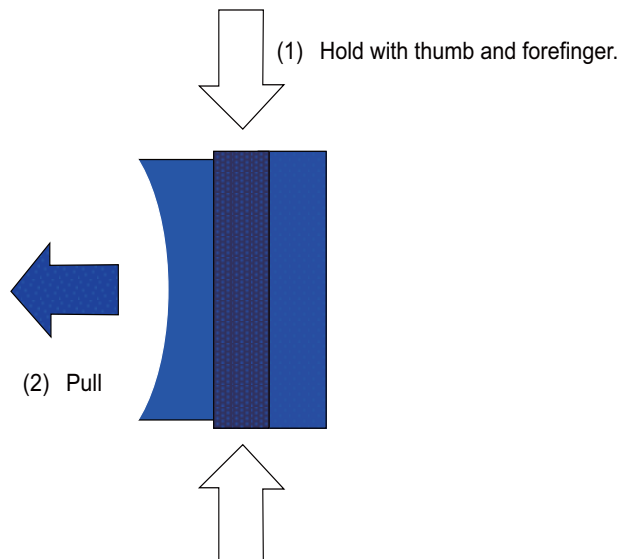

- (d) For the screw fixed type connector, loosen the two fixing screws, and pull the connector off.

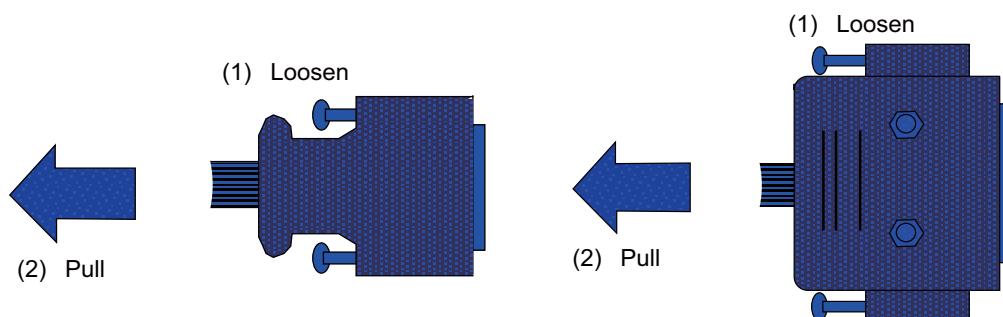

⚠ CAUTION

1. Do not connect or disconnect the cables between units while the power is ON.
2. Do not pull the cables when connecting/disconnecting it.

(e) For the optical cable connector, pull off while holding down the lock button.

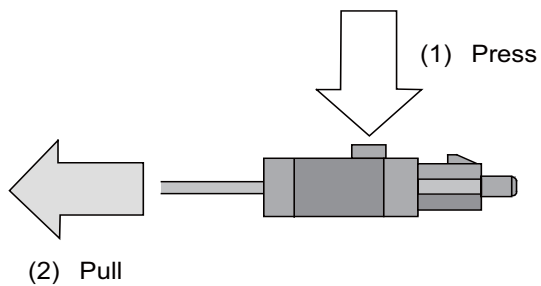

(f) For the Ethernet connector, pull off while holding down the locked latch.

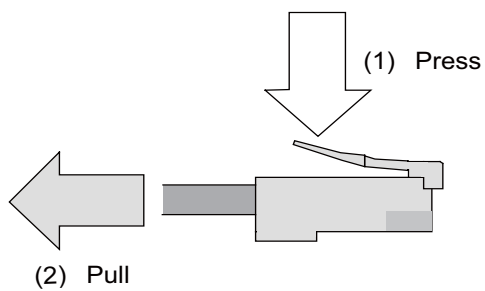

⚠ CAUTION

1. Do not connect or disconnect the cables between units while the power is ON.
2. Do not pull the cables when connecting/disconnecting it.

4.1.2 Precautions for Using Optical Communication Cable

An optical communication cable is used for communication between the control unit and the drive unit. Special precautions, differing from the conventional cable, are required when laying and handling the optical communication cable.

(Note) If the cable you use is not Mitsubishi's, malfunctions resulted from connection problems or aged deterioration are not covered under the warranty.

4.1.2.1 Optical Communication Cable Outline and Parts

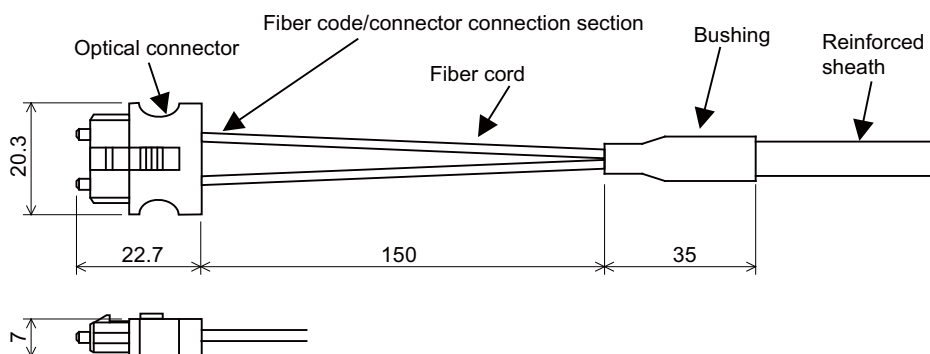

To ensure the system performance and reliability, purchase the optical communication cable from Mitsubishi. A machining drawing is given in "Cable" as reference, but the purchased optical communication cable cannot be cut or connected by the machine tool builder.

4.1.2.2 Precautions for Handling Optical Communication Cable

- (1) A protective cap is attached to the optical module and optical communication cable mounted on the PCB when the system is delivered. Leaving this protective cap unattached could result in connection faults from the adherence of dirt and dust. Do not remove the protective cap when not connecting the cable. If dirty, wipe off lightly with a piece of dry gauze, etc. (Do not use solvents such as alcohol as the optical fiber material could melt.)
- (2) Hold the connector section when connecting or disconnecting the optical connector. Holding the fiber cord will result in force exceeding the tolerable tension on the fiber cord and connector connection section, and could cause the fiber cord to dislocate from the optical connector thereby inhibiting use.
- (3) The optical connector cannot be connected in reversed. Check the connector orientation when connecting the optical communication cable to the optical module. Align the connector lock lever with the lock holes on the PCB's optical module, and press the connector straight in. Confirm that the lock lever connects with the optical module and that a "click" is heard.
- (4) When disconnecting the optical communication cable from the PCB, press the lock release buttons on the lock lever, and pull out the cable while holding the connector section. The connector could be damaged if the cable is pulled without pressing down on the lock release buttons.
- (5) Do not apply excessive force onto the optical communication cable by stepping on it or dropping tools, etc., on it.

4.1.2.3 Precautions for Laying Optical Communication Cable

- (1) Do not apply a force exceeding the cable's tolerable tension. Binding the cables too tight with tie-wraps could result in an increased loss or a disconnection. Use a cushioning material such as a sponge or rubber when bundling the cables and fix so that the cables do not move.
- (2) Do not connect the cables with a radius less than the tolerable bending radius. Excessive stress could be applied near the connector connection section and cause the optical characteristics to drop. The cable bending radius should be 10 times or more than the outer diameter at the reinforced sheath, and 20 times or more than the outer diameter at the fiber cord section.
- (3) Do not apply torsion to the optical communication cable. Laying a twisted cable could cause the optical characteristics to drop.
- (4) When laying the cables in a conduit, avoid applying stress on the fiber cord and connector connection section. Use the tensile end such as a pulling eye or cable grip, etc.
- (5) Fix the reinforced sheath with a cable clamp so that the mass of the optical communication cable is not directly applied on the fiber cord and connector connection section.
- (6) Never bundle the cables with vinyl tape. The plasticizing material in the vinyl tape could cause the POF cable to break.
- (7) Loop the excessive cable with twice or more than the minimum bending radius.

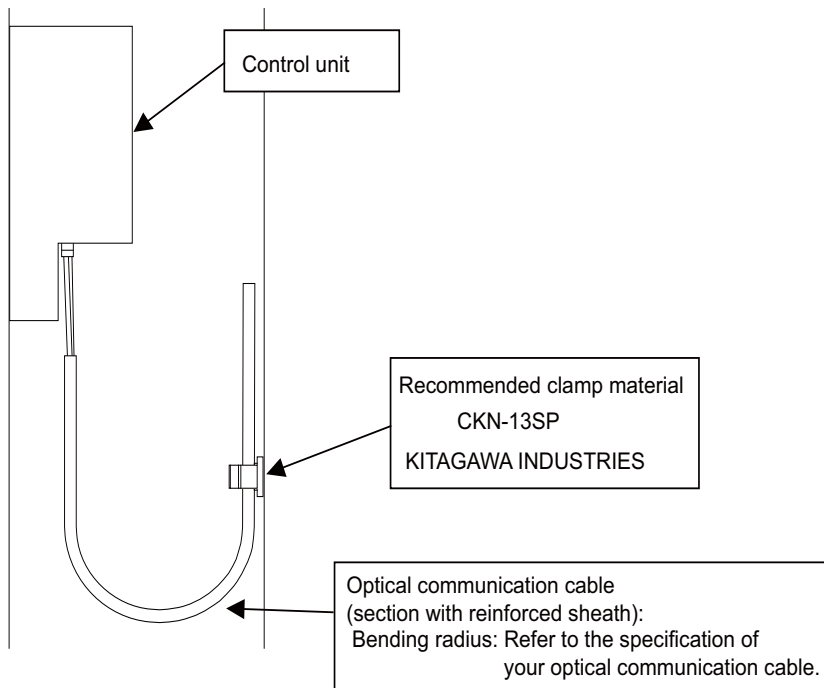

4.1.3 Precautions for Connecting 24V Power Supply

- (1) When 24V power is supplied to the unit (control unit, display unit) under the following conditions, welding may occur on the contacts due to rush current; so be careful.

When 24VDC's ON/OFF are directly controlled by a magnetic switch such as relay AND
 When heat capacity of the contacts for relay, etc. used to control 24VDC's ON/OFF is small.

4.2 Connection of Control Unit

The method for connecting to each unit and device from the control unit is explained in this section.

4.2.1 Control Unit Connection System Drawing

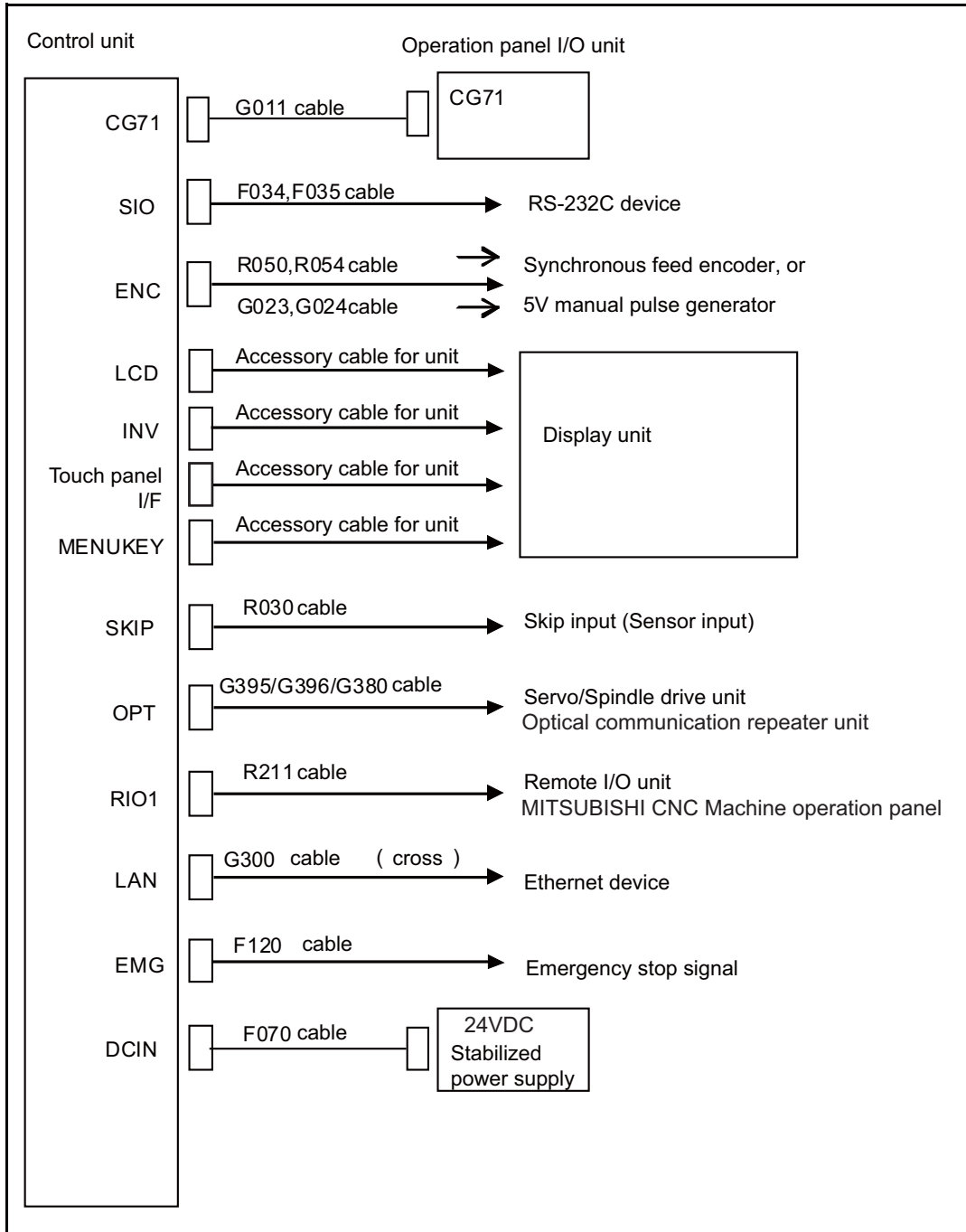

4.2.2 Connecting with Power Supply

Connect a general-purpose 24VDC stabilized power supply or PD25 power supply unit to the control unit.

(1) When using general-purpose 24VDC stabilized power supply

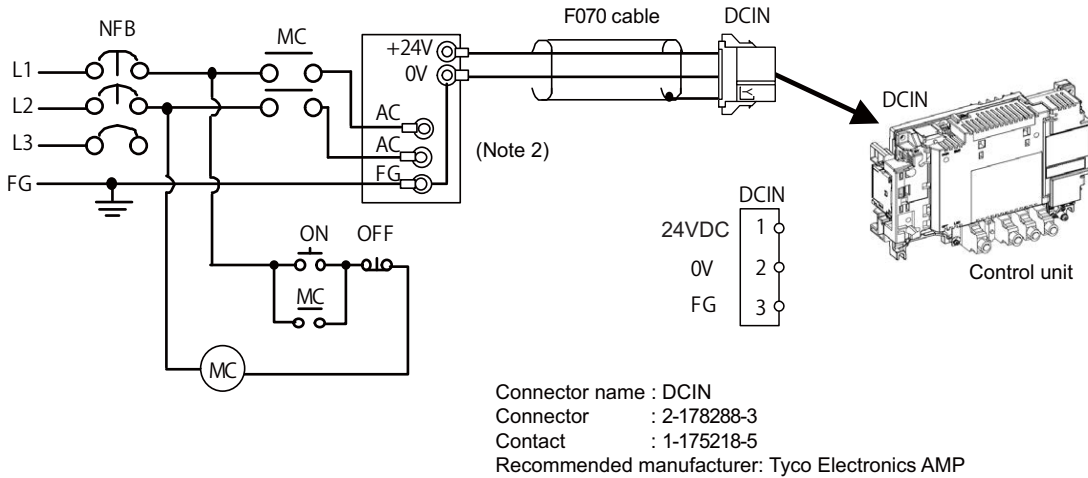

(Note 1) Rush current may occur to lead welding on the contacts, when a magnetic switch such as relay directly controls 24VDC's ON/OFF during 24V power supply to the control unit. Use relay with large heat capacity of contacts to control 24VDC's ON/OFF.

(Note 2) Make a short-circuit between 0V and FG on the terminal to cut noise.

<Related items>

Cable drawing "Cable: F070 Cable"

Connector pin assignment: "General Specifications: Control Unit" (DCIN connector)

(2) When using PD25 power supply unit

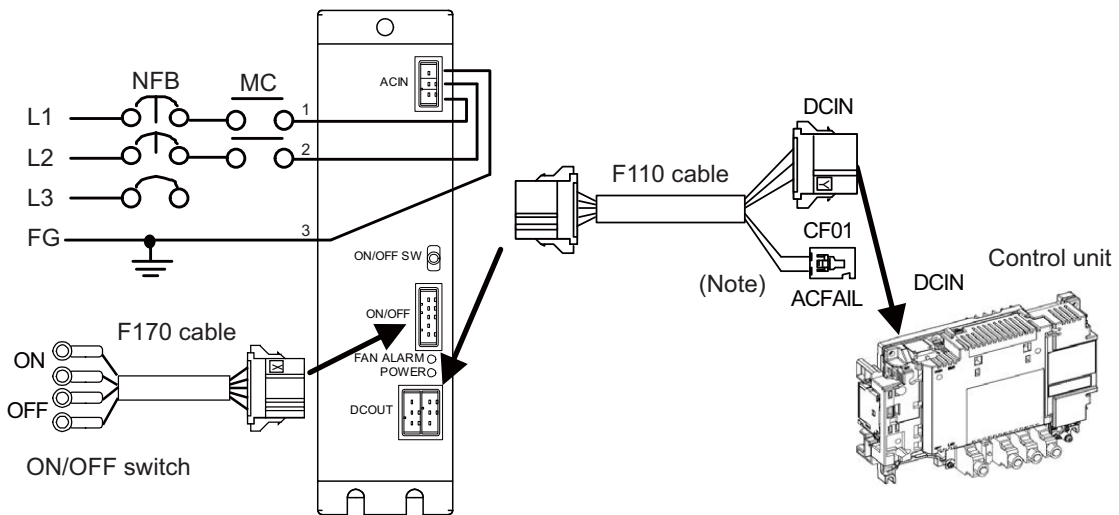

(Note) ACFAIL function is not available with this NC system. (CF01 is not connected.)

<Related items>

Cable drawing: "Cable: F110 Cable", "Cable: F170 Cable"

Connector pin assignment: "General Specifications: Control Unit" (DCIN connector)

4.2.3 Connecting with Emergency Stop Signal

Connect the emergency stop switch to EMG connector by F120 cable.

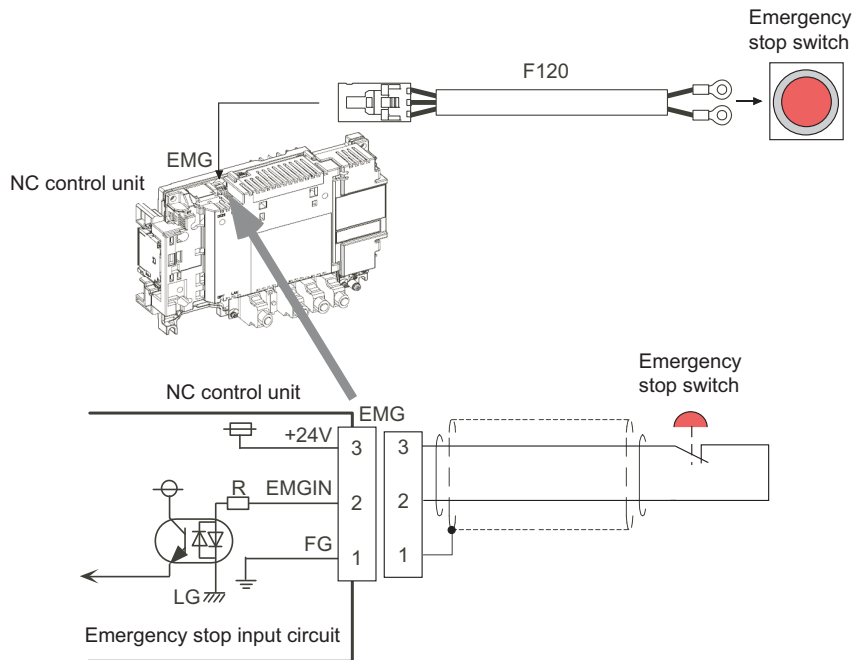

<Related items>

Cable drawing: "Cable: F120 Cable"

Besides the emergency stop input from the NC controller, double-protection when an emergency stop occurs can be provided by directly inputting an external emergency stop to the drive unit. Even if the emergency stop is not input from NC for some reason, the contactors can be shut off by the external emergency stop input. Outlines are shown below. For more details, refer to the Instruction Manual of each drive unit.

<Drive unit (MDS-DM2-SPV) external emergency stop: Example 1>

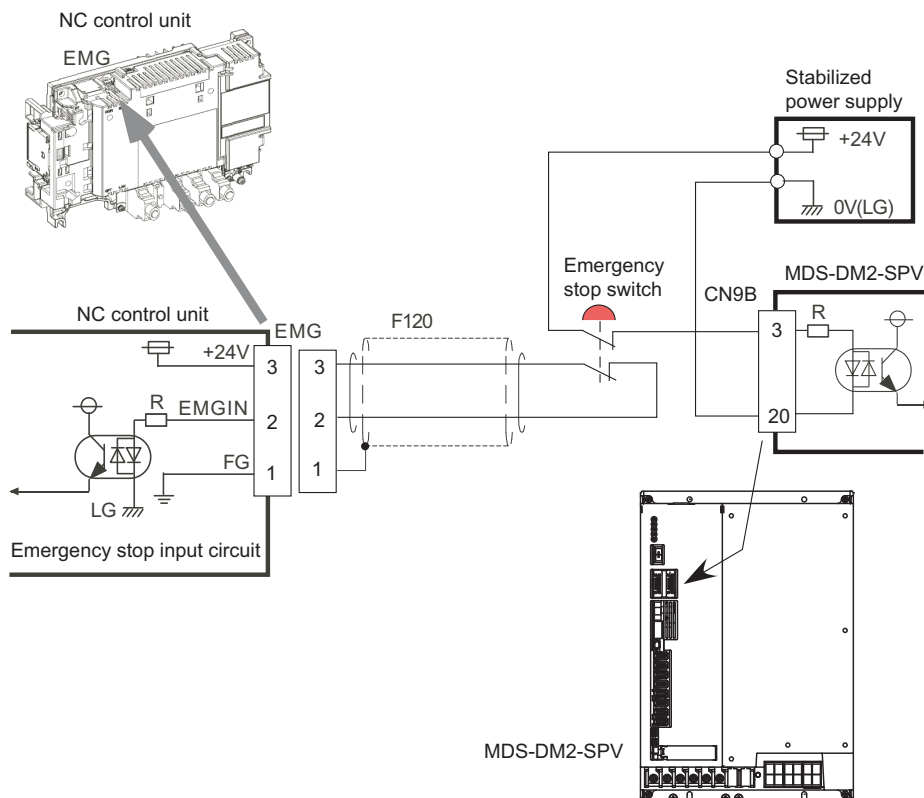

<Drive unit (MDS-DJ-V1) external emergency stop: Example 2>

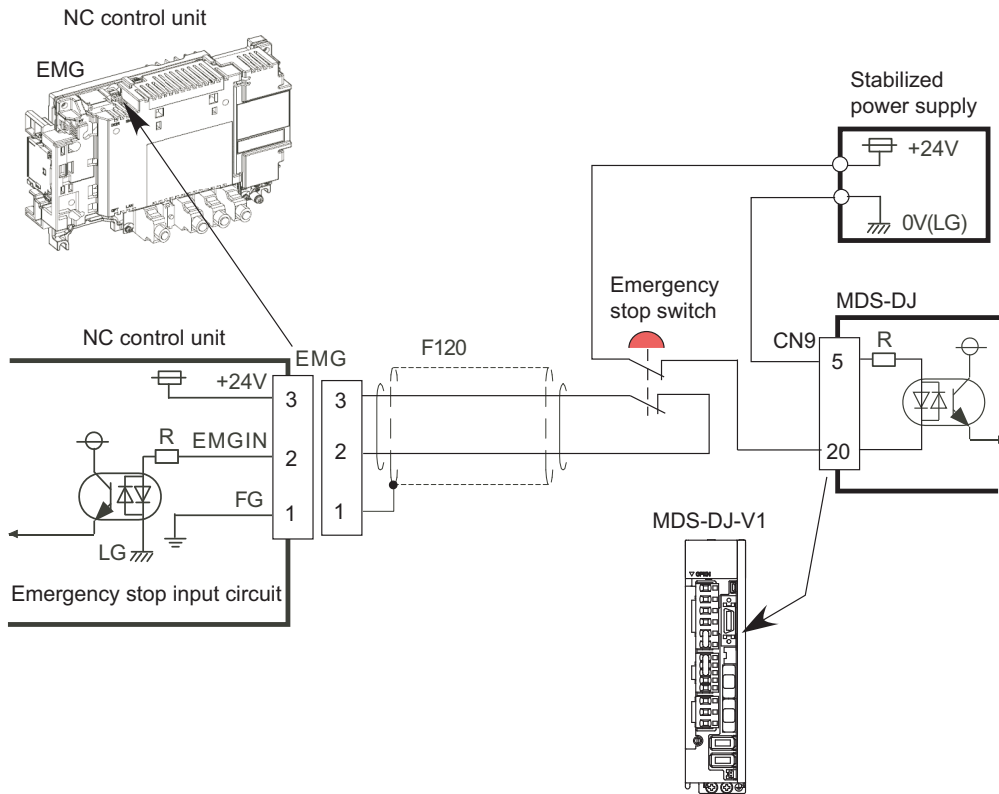

<Caution>

- (1) External emergency stop cannot substitute the emergency stop signal which is input to NC. It is a function which helps the NC emergency stop.
- (2) When duplicating emergency stop input, wire the NC emergency stop input and the drive unit external emergency stop input from the same emergency stop switch.

4.2.4 Connecting with Operation Panel I/O Unit

Connect the operation panel I/O unit to the connector CG71.

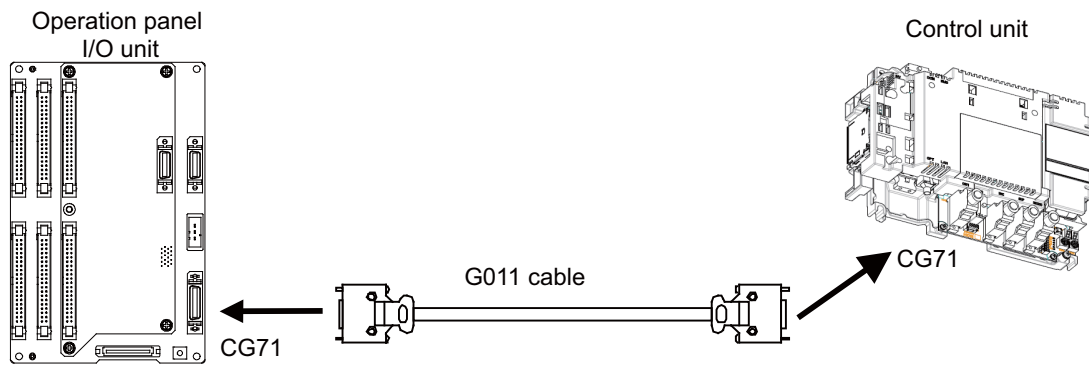

<Related items>

Cable drawing: "Cable G011 Cable"

Connector pin assignment: "General Specifications: Control Unit" (CG71 connector)

4.2.5 Connecting with Drive Unit

Connect the optical communication cables from the NC to the each drive unit so that they run in a straight line from the NC to the drive unit that is a final axis. Up to 6 axes can be connected. Note that the number of connected axes is limited by the NC.

(Note) Refer to "Precautions for Using Optical Communication Cable" when handling and wiring optical communication cable.

Cable application table

Cable	Panel internal wiring		Panel external wiring	
	Under 10m	10 to 30m	10m or less	10 to 30m
G396	○	×	×	×
G395	○	×	○	×
G380	○	○	○	○

4.2.5.1 Connecting with MDS-DM2 Series

CAUTION

Connect the NC and the drive units by the optical communication cables. The distance between the NC and the final drive unit must be within 30m and the bending radius within 80mm.

POINT

As for MDS-DJ series, axis Nos. are determined by the rotary switch for setting the axis No. (Refer to the MDS-DJ Series Instruction Manual.) The axis No. has no relation to the order for connecting to the NC.

(1) When using only MDS-DM2-SPV Series

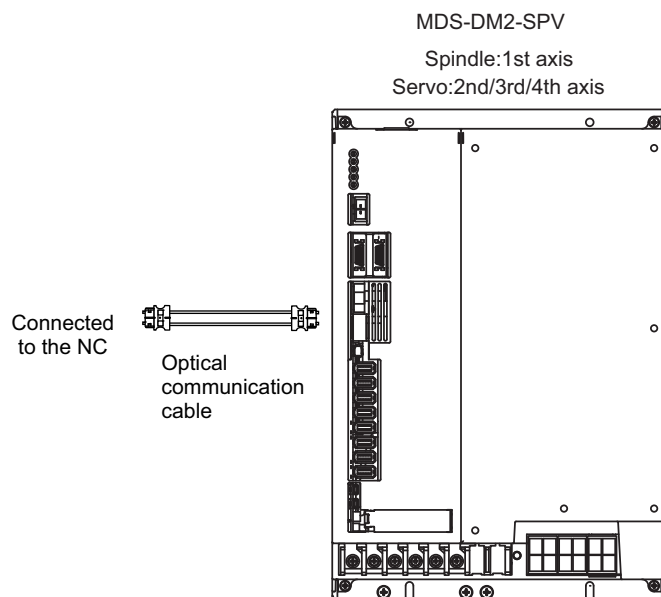

(2) When using the MDS-DJ unit together

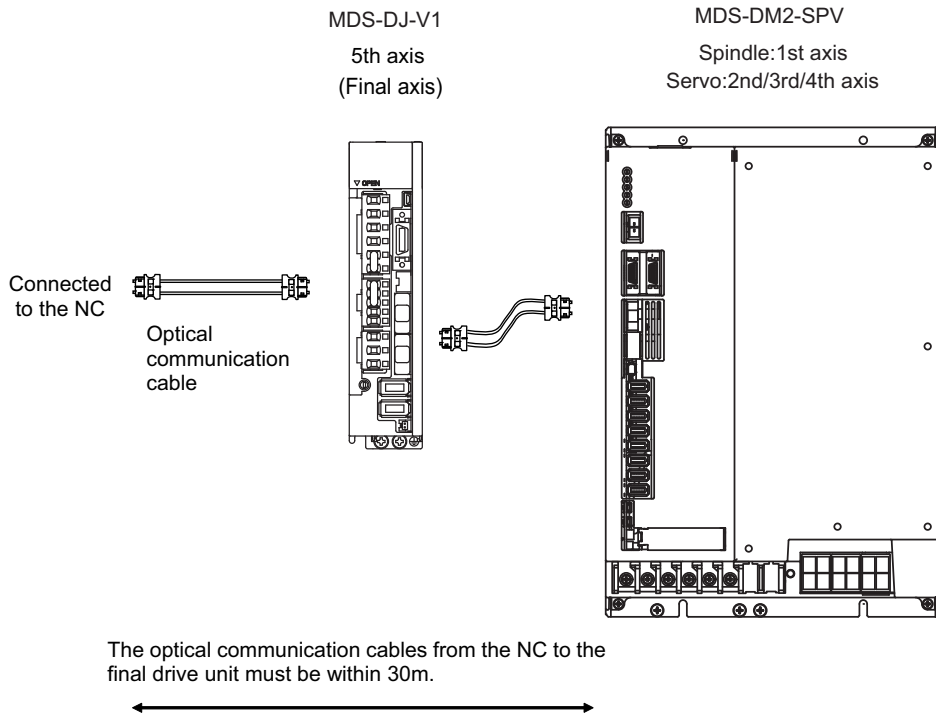

4.2.5.2 Connecting with MDS-DJ Series

CAUTION

Connect the NC and the drive units by the optical communication cables. The distance between the NC and the final drive unit must be within 30m and the bending radius within 80mm.

POINT

Axis Nos. are determined by the rotary switch for setting the axis No. (Refer to the MDS-DJ Series Instruction Manual.) The axis No. has no relation to the order for connecting to the NC.

<Connection>

CN1A: CN1B connector on NC or previous stage's drive unit

CN1B: CN1A connector on next stage's drive unit

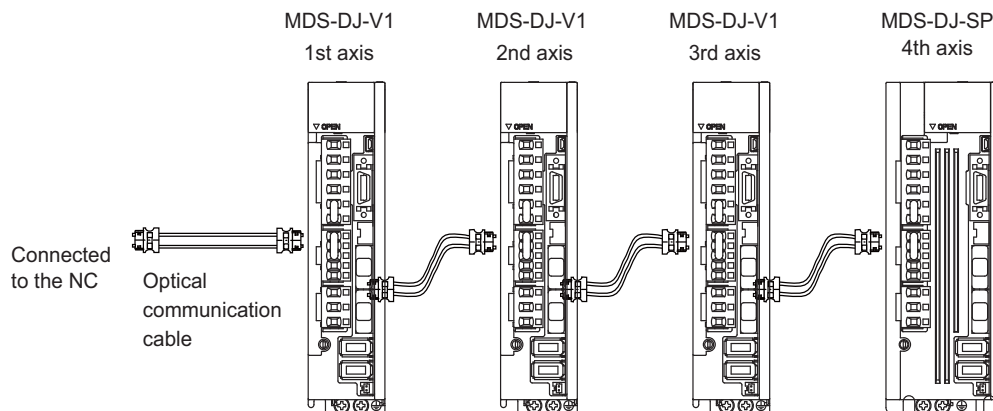

The optical communication cable up to 5m can be used in G396 series, up to 10m in G395 series, and up to 30m in G380 series.

4.2.6 Connecting with RS-232C Device

- (1) Connect the RS-232C device to the connector SIO.

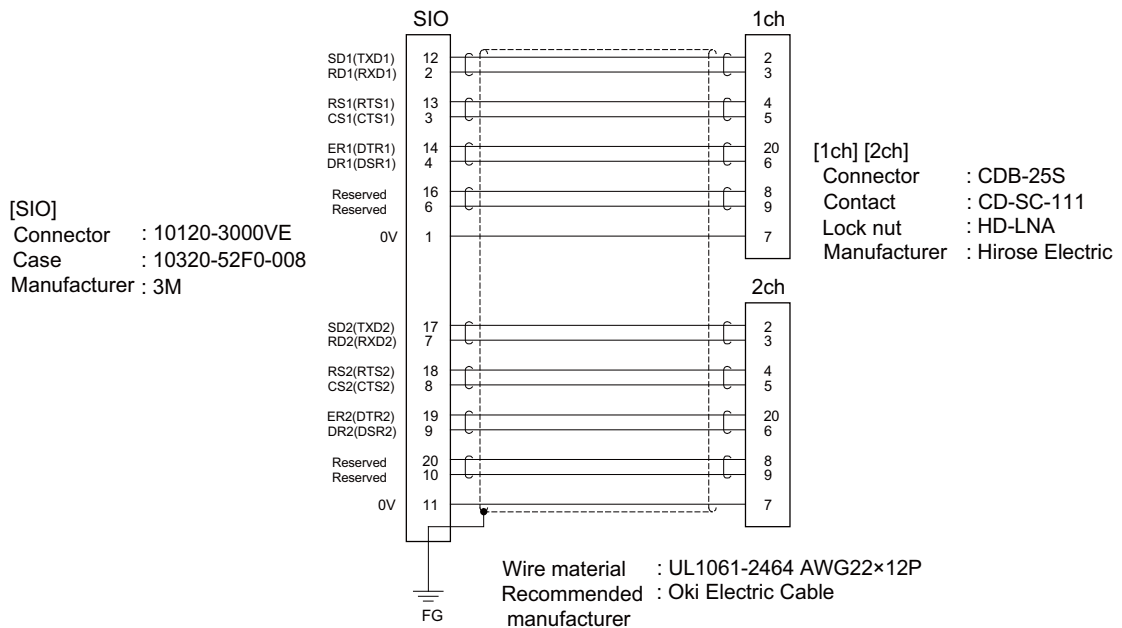
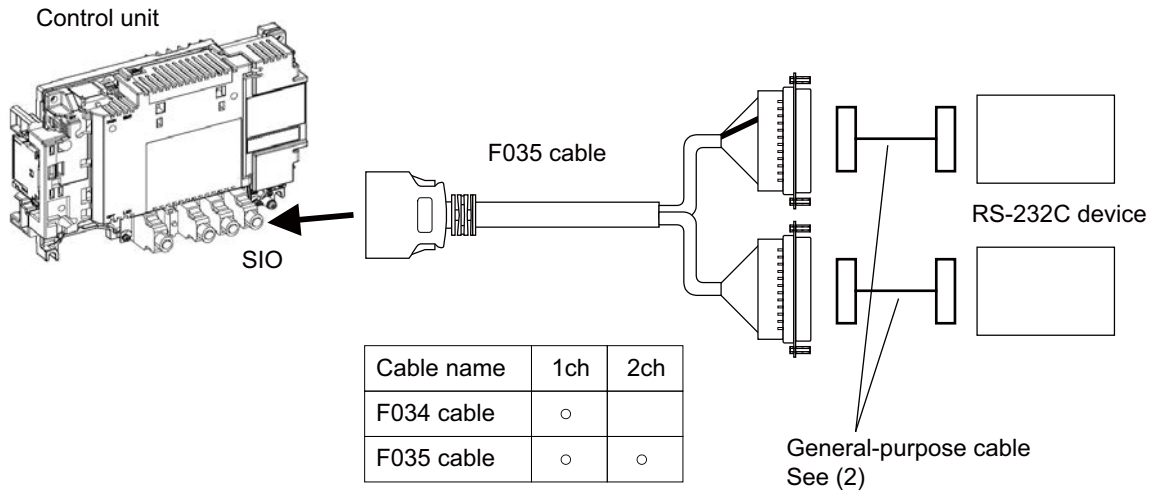

<Related items>

Cable drawing: "Cable: F034/F035 Cable"

Connector pin assignment: "General Specifications: Control Unit" (SIO connector)

(2) Example of wiring connections to the RS-232C device

When connecting to the RS-232C device, refer to the following diagrams and cross the wiring for the transmission signals.

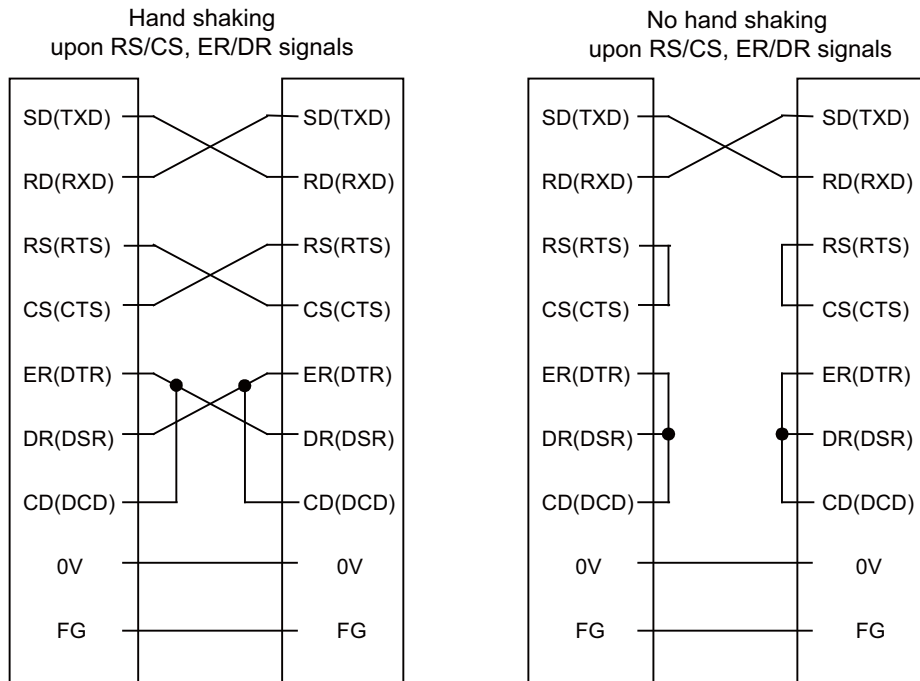

4.2.7 Connecting with Skip Signal (Sensor)

Connect skip signals to the connector SKIP.

Skip signals are used for processing high-speed signals. Always shield the cable.

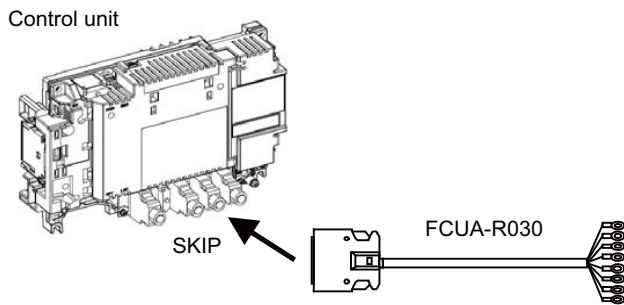

(Note) Connecting the skip signal cable to a wrong connector causes a damage on the control unit when turning ON the skip signal power supply. Confirm the wiring before turning the power ON.

(1) Connection of skip signal cable

<0V connection at COM terminal>

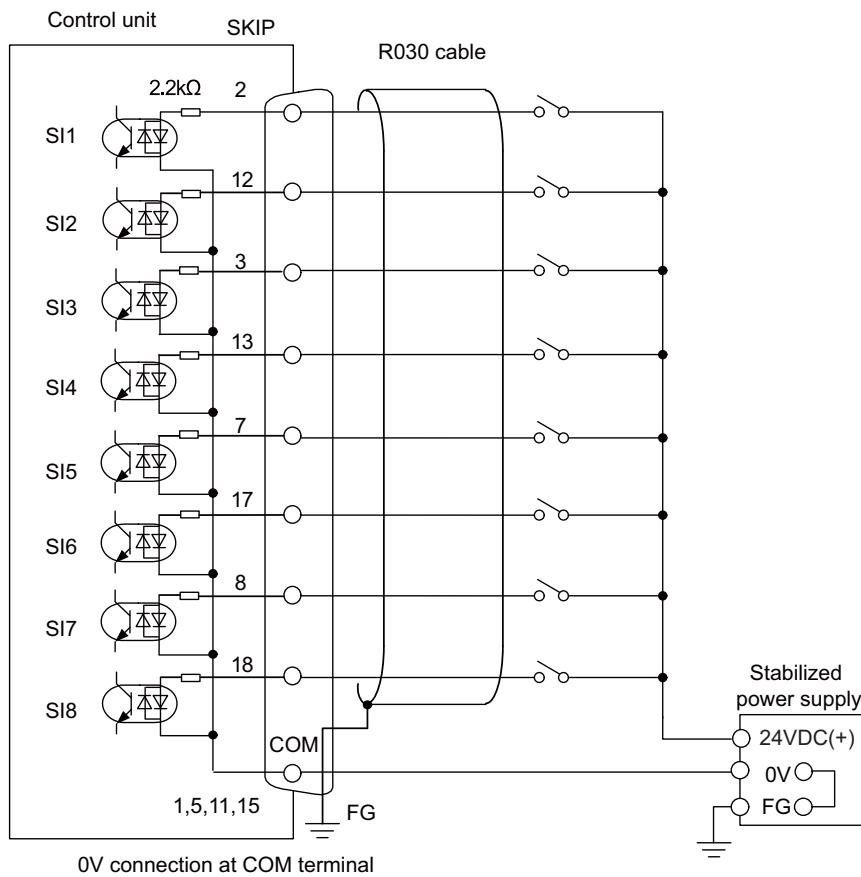

<24V connection at COM terminal>

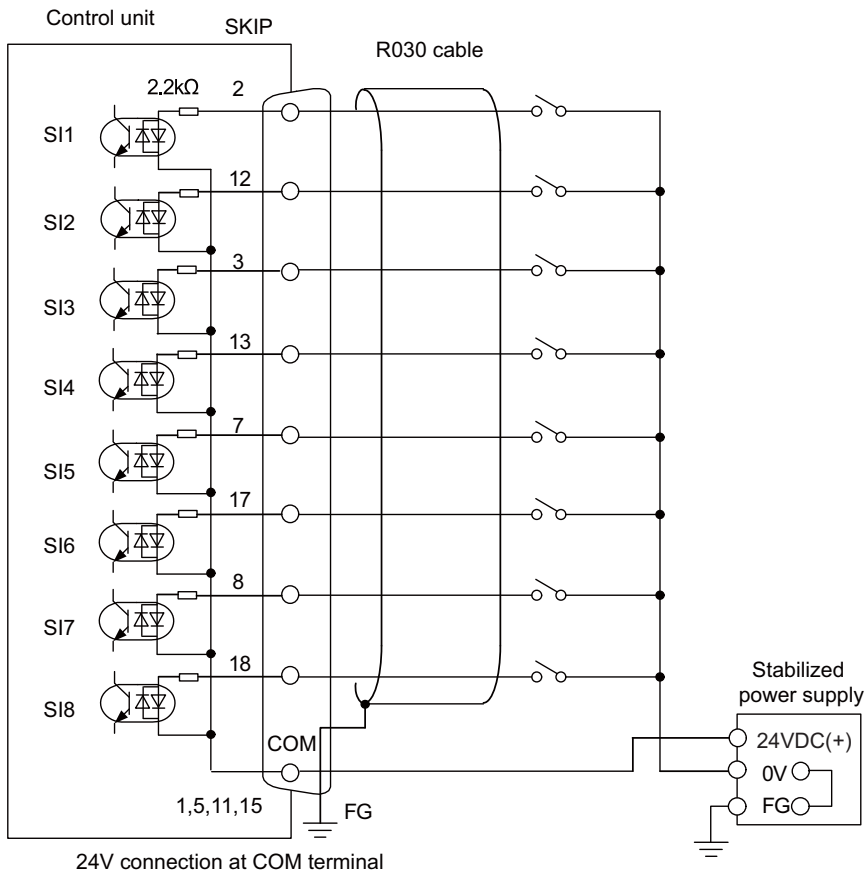

- (Note 1) NC recognizes input signals of 2ms or more as the valid skip signals. If machine contacts (relay, etc.) are used, malfunctions will occur due to chattering. Use semiconductor contacts (transistor, etc.).
- (Note 2) Fold the cable shield over the sheath, and wrap copper foil tape over it. Connect the wound copper foil tape to GND plate of the connector.

<Related items>

Cable drawing: "Cable: FCUA-R930 Cable"

Connector pin assignment: "General Specifications: Control Unit" (SKIP connector)

4.2.8 Connecting with Synchronous Feed Encoder/ Manual Pulse Generator

Synchronous feed encoder (1ch) or 5V power supply type manual pulse generator (2ch) can be connected.

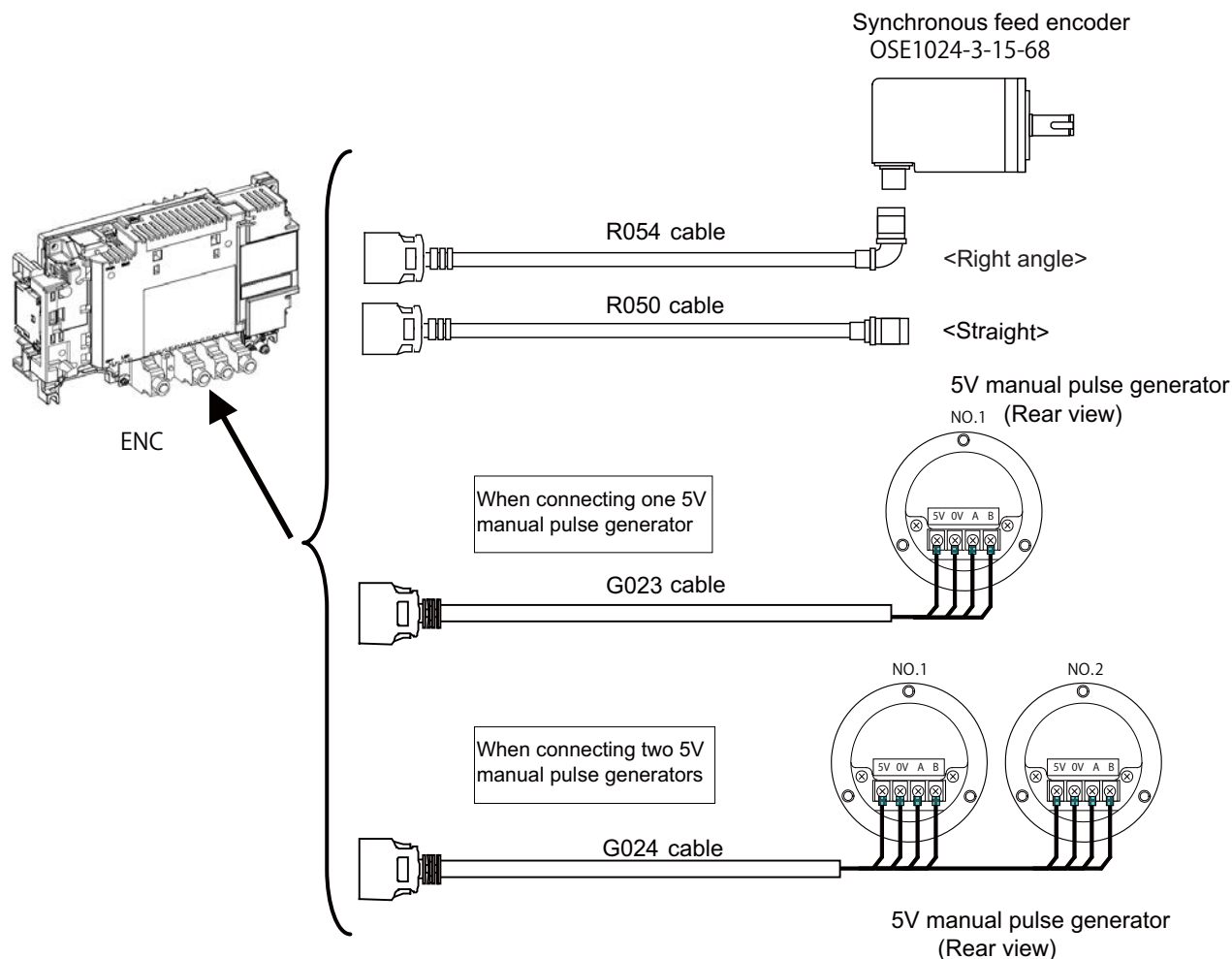

<Related items>

Cable drawing: "Cable: FCUA-R050/R054 Cable" and "Cable: G023/G024 Cable"

Connector pin assignment: "General Specifications: Control Unit" (ENC connector)

When using the synchronous feed encoder and the manual pulse generator at the same time, the cables must be prepared by the machine tool builder.

4.2.8.1 Handle Numbers

Unit configuration decides handle Nos.

"ENC": Connector on control unit "MPG": Connector on operation panel I/O unit

Operation panel I/O unit (FCU7-DX71x/ DX72x/ DX73x/DX621)	1st handle	2nd handle	3rd handle
Used	"MPG" 1ch	"MPG" 2ch	"ENC" 1ch (Note)
Not used	"ENC" 1ch	"ENC" 2ch	-

(Note) If one handle is only connected to "MPG", the handle connected to "ENC" 1ch will still be treated as the 3rd handle. "ENC" 2ch is not employed when an operation panel I/O unit is used.

4.2.9 Connecting with Safety Observing I/O Device

Connect safety observing I/O device as the example below. (Below is an example where an MDS-DJ series drive unit is used.)

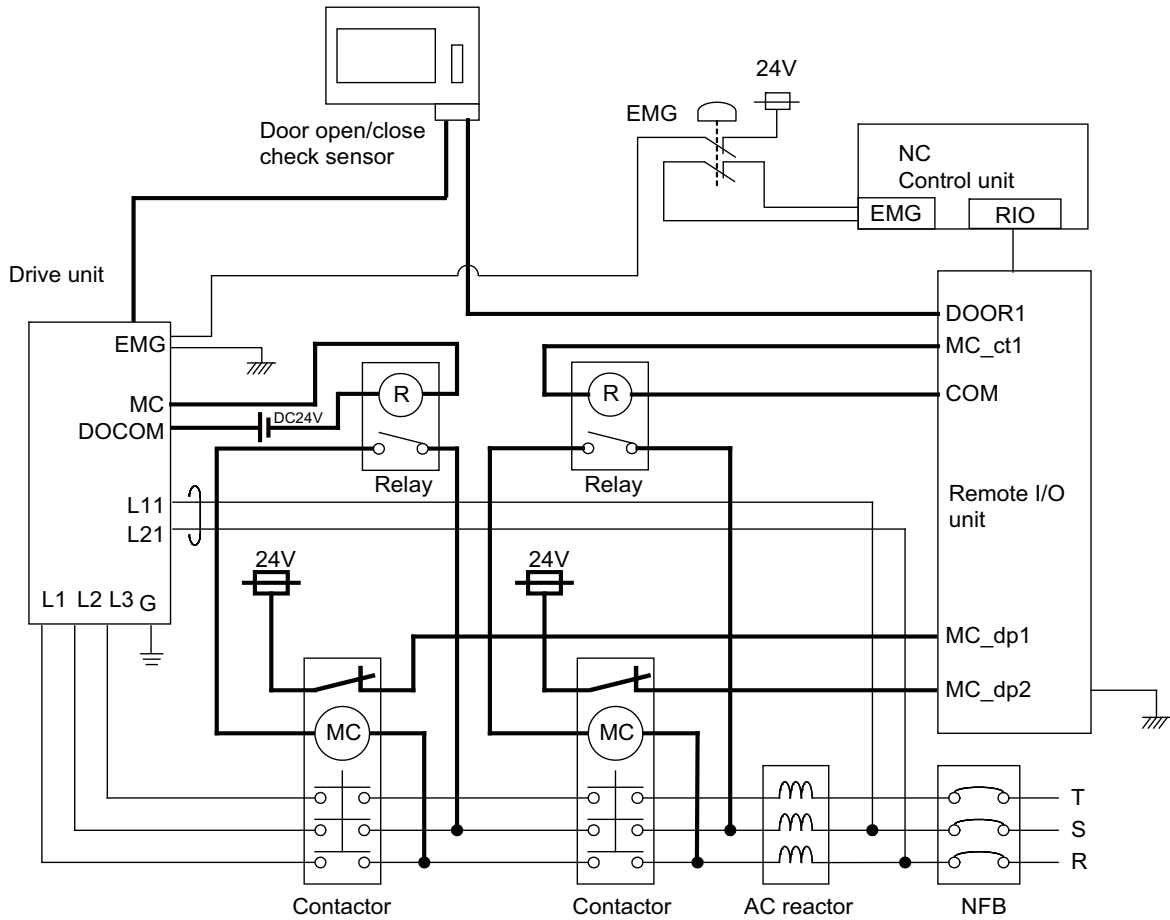

Safety observing functions follow "IEC61800-5-2/EN61800-5-2", and safety of the functions complies with "EN ISO13849-1:2008 (PL d, Category 3)". However, make sure to check the safety of the machine by using "risk assessment".

With this function, the following executions can be realized.

- (1) Open the door without shutting the motor drive power OFF.
- (2) Operate under the safety speed or lower while the door is opened.

Refer to the "Safety Handbook (Original Instructions)" (IB-1501025) for the details of the connection with the safety observing I/O devices.

Refer to the instruction manual of the drive unit for the details of the connection with the drive unit.

4.3 Connection of Operation Panel I/O Unit

4.3.1 Operation Panel I/O Unit Connection System Drawing

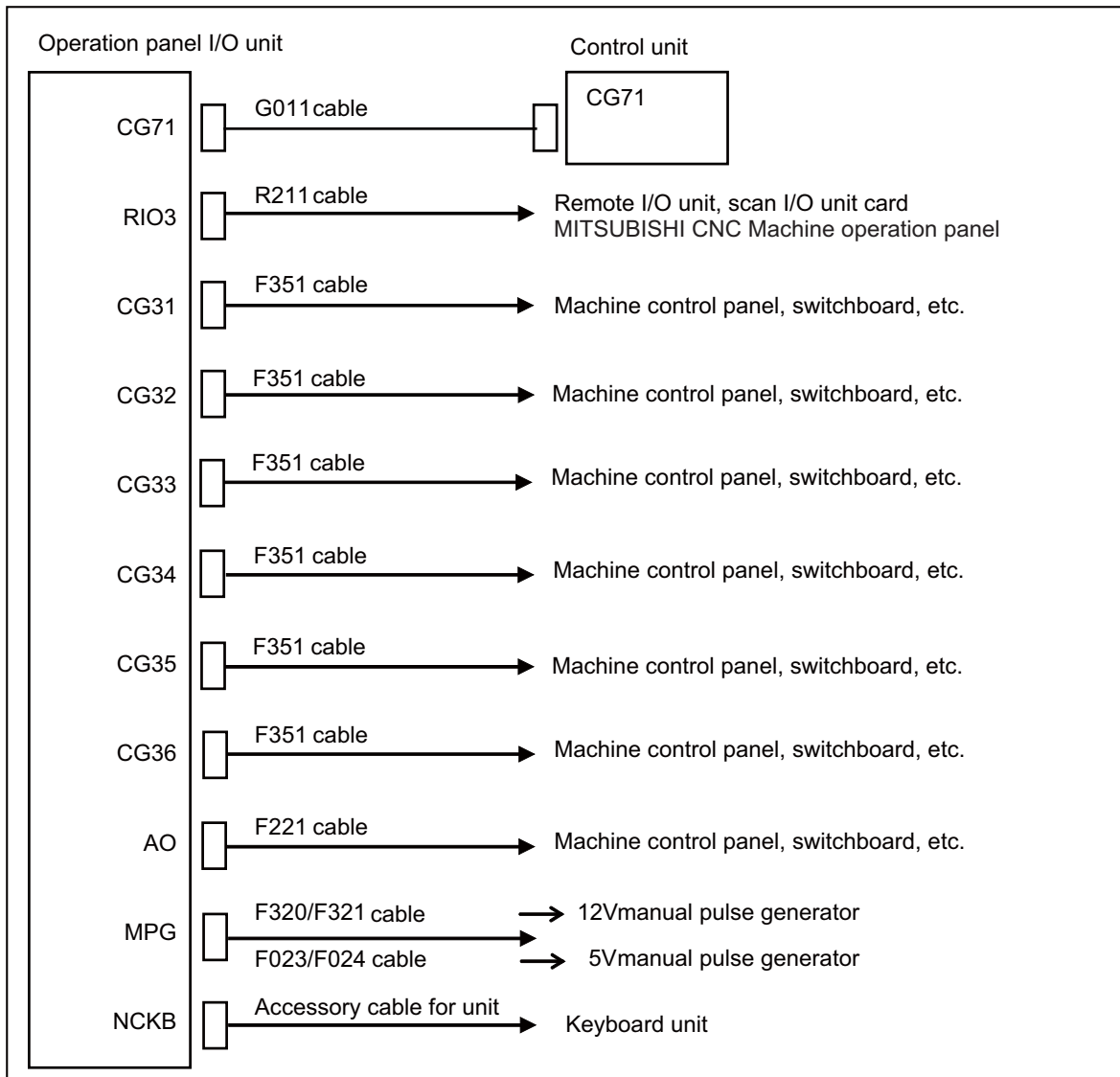

4.3.2 Connecting with Keyboard Unit

Connect the keyboard unit to the connector NCKB.
The cable comes with the keyboard unit.

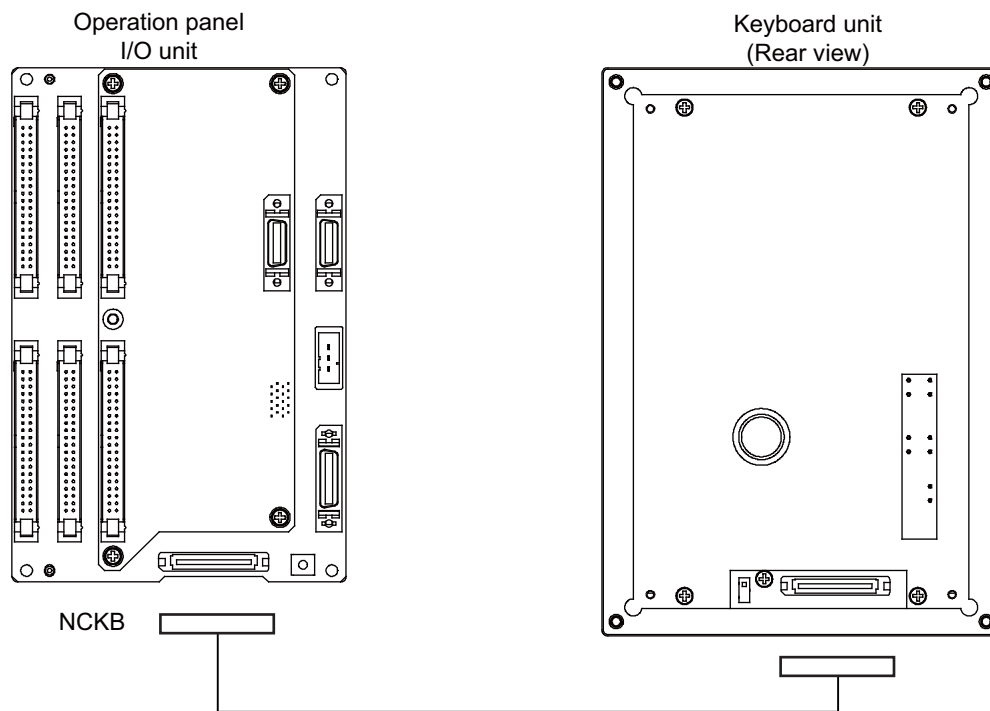

(Note) Firmly insert the connection cable until it is locked.

4.3.3 Connecting with Manual Pulse Generator (MPG)

Both 5V power supply type (UFO-01-2Z9) and 12V power supply type (HD60C) manual pulse generator can be used. Take the maximum cable length, etc. into consideration when selecting.

(Note) Set one of the following parameters which is suitable for your manual pulse generator.

- 5V manual pulse generator (UFO-01-2Z9) : #1240 set12/bit0 = 1 (100 pulse/rev)
- 12V manual pulse generator (HD60C) : #1240 set12/bit0 = 0 (25 pulse/rev)

(1) Connecting with 5V manual pulse generator (maximum cable length: 20m)

Connect the 5V manual pulse generator to the connector MPG.

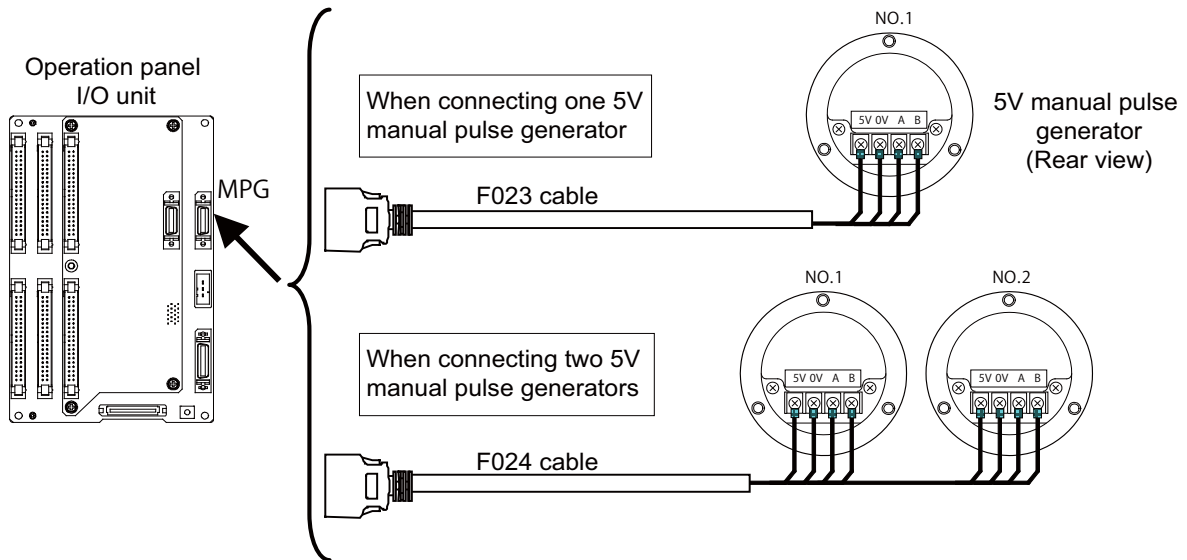

(2) Connecting with 12V manual pulse generator (maximum cable length: 50m)

Connect the 12V manual pulse generator to the connector MPG.

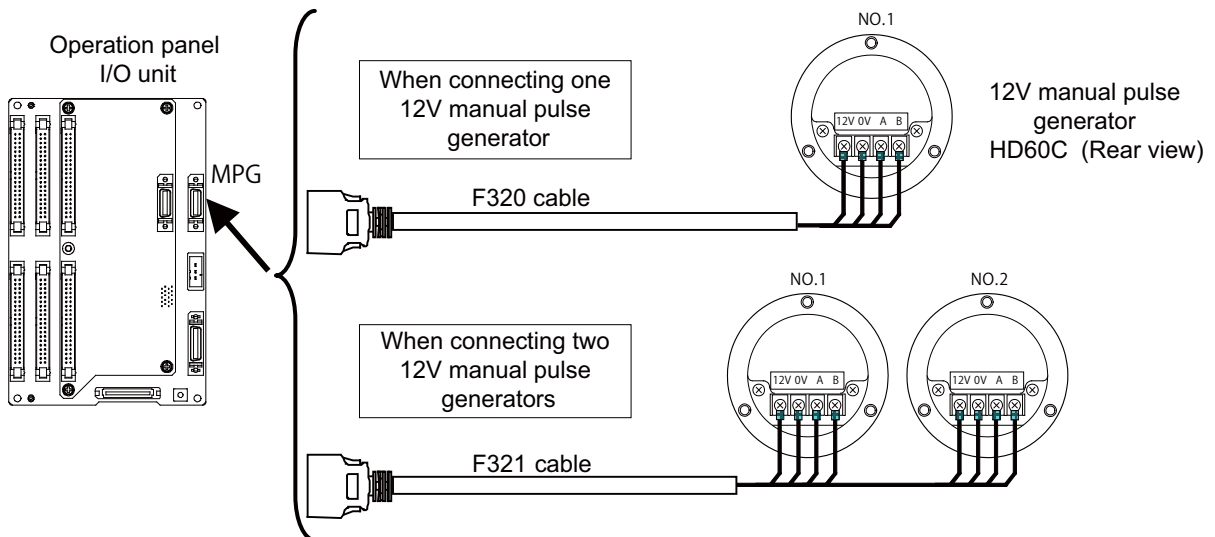

(Note 1) When selecting a manual pulse generator, make sure that its case and 0V terminal are insulated.

(Note 2) Select 25pulse/rev or 100pulse/rev on the parameter screen.

<Related items>

Cable drawing: "Cable: F023/F024 Cable"

Connector pin assignment: "General Specifications: Operation Panel I/O Unit" (MPG connector)

4.3.3.1 Handle Numbers

Unit configuration decides handle Nos.

"ENC": Connector on control unit "MPG": Connector on operation panel I/O unit

Operation panel I/O unit (FCU7-DX71x/ DX72x/ DX73x/DX621)	1st handle	2nd handle	3rd handle
Used	"MPG" 1ch	"MPG" 2ch	"ENC" 1ch (Note)
Not used	"ENC" 1ch	"ENC" 2ch	-

(Note) If one handle is only connected to "MPG", the handle connected to "ENC" 1ch will still be treated as the 3rd handle. "ENC" 2ch is not employed when an operation panel I/O unit is used.

4.3.4 Connecting with Machine Operation Panel

Connect the machine operation panel to the connector CG31, CG32, CG33, CG34, CG35 or CG36.

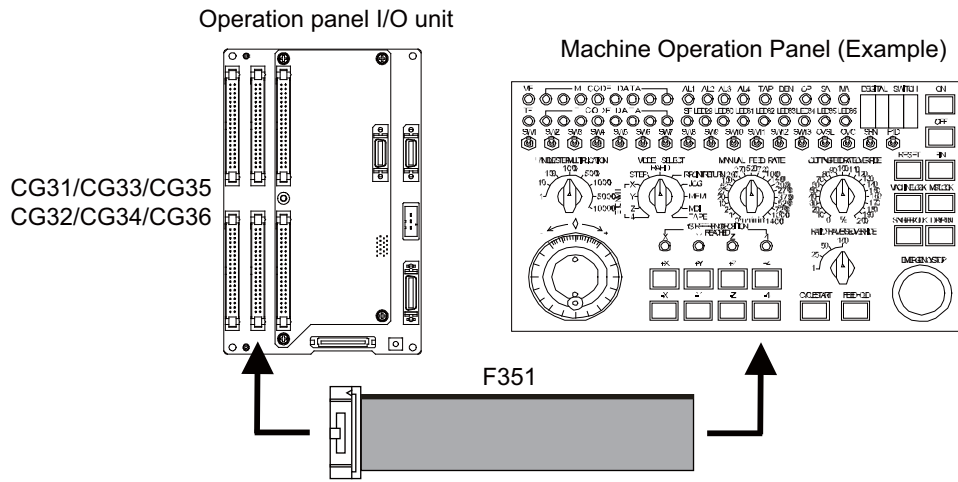

<Related items>

Cable drawing: "Cable: F351 Cable"

Connector pin assignment: "General Specifications: Operation Panel I/O Unit" (CG31/CG32/CG33/CG34/CG35/CG36 connector)

4.3.4.1 Wiring for 24V Common Input

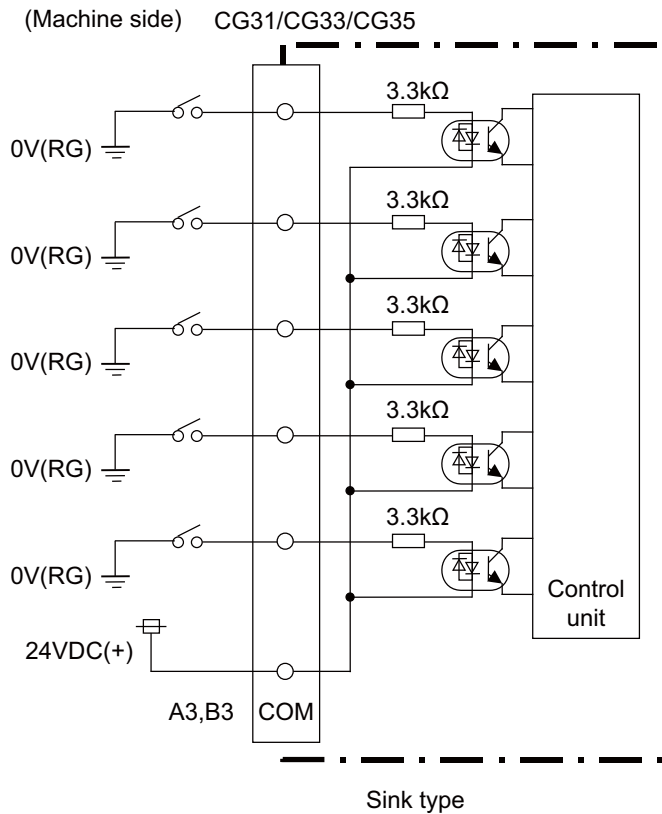

For connection details, refer to the descriptions on machine input connector pin assignment in "(1) Machine input (CG31)", "(2) Machine input (CG33)", and "(3) Machine input (CG35)" under Section "General Specifications: Operation Panel I/O Unit".

4.3.4.2 Wiring for 0V Common Input

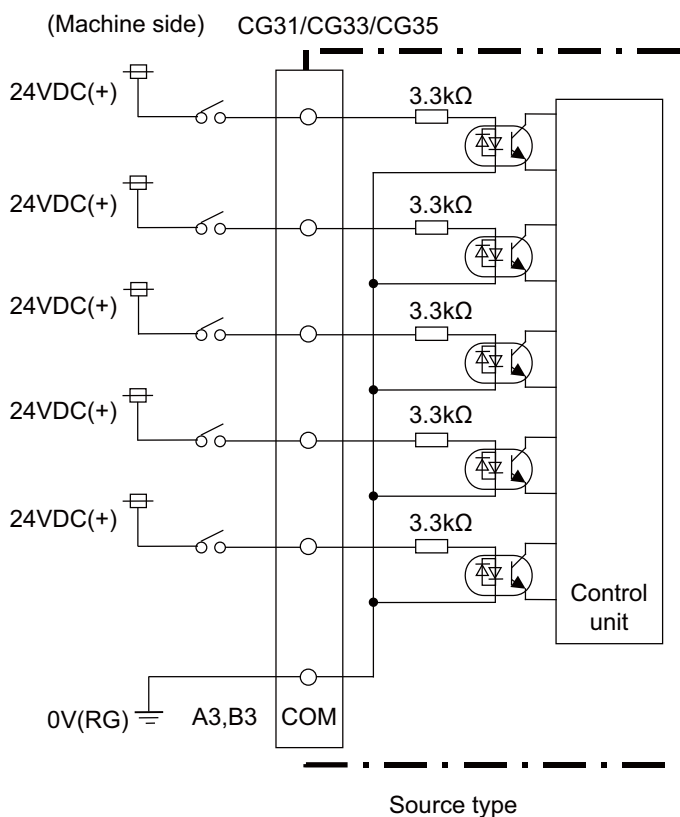

For connection details, refer to the descriptions on machine input connector pin assignment in "(1) Machine input (CG31)", "(2) Machine input (CG33)", and "(3) Machine input (CG35)" under Section "General Specifications: Operation Panel I/O Unit".

4.3.4.3 Wiring for Source Type Output (FCU7-DX621/DX711/DX721/DX731)

Operation panel I/O unit

(Card name : HN331/HN351/HN371/HN372)

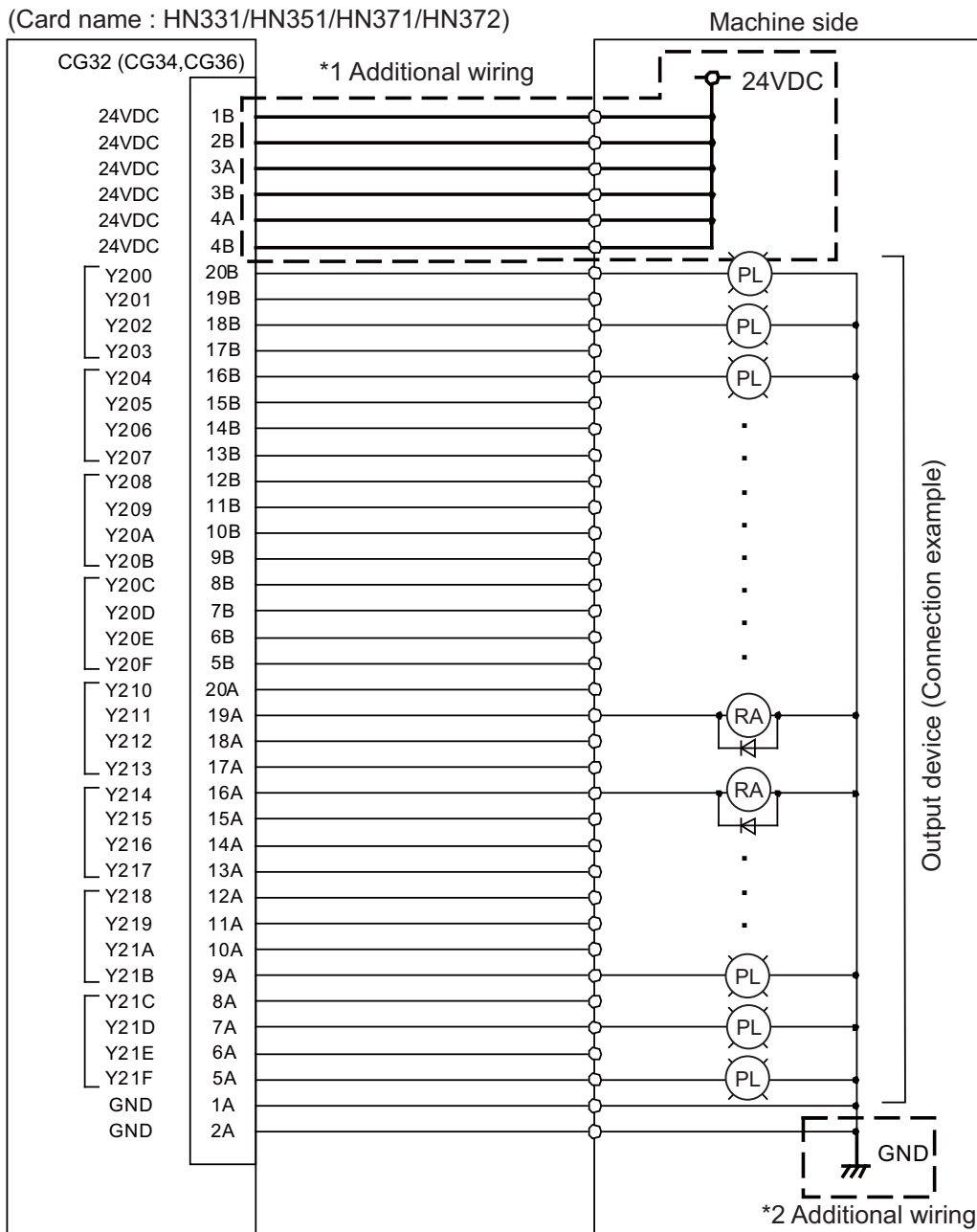

RA : Relay
PL : Pilot lamp

- (Note 1) Connect +24V to either or both of the flat connector 1B, 2B (24VDC). (*1)
- (Note 2) Connect +24V (GND) to the flat connector 3A, 3B, 4A, 4B (24VDC). (*1)
Decide the number of 24VDCs to wire with regard to the total amount of each connector's maximum output current and the voltage drop by the cables. The rated current is 1A per connector pin.
- (Note 3) Connect 0V (GND) to the flat connector 1A, 2A (GND). (*2)
- (Note 4) When large current flows due to small amount of connected load, fuse may be blown out or 24V power supply voltage may drop. In order to secure the appropriate current value, watch the connected load.

4.3.4.4 Outline of Analog Signal Output Circuit

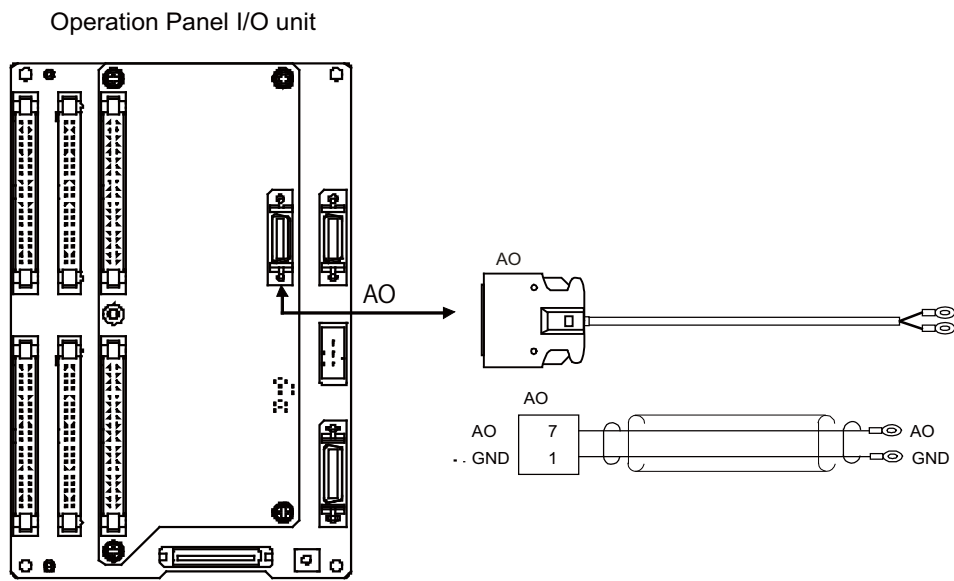

The analog signal output circuit can be used only for the FCU7-DX621/DX721.

4.4 Connection of Remote I/O Unit

This chapter describes the connection of the remote I/O unit and machine control signals.

4.4.1 Connection and Station No. Setting on Remote I/O Unit

When connecting directly to the control unit

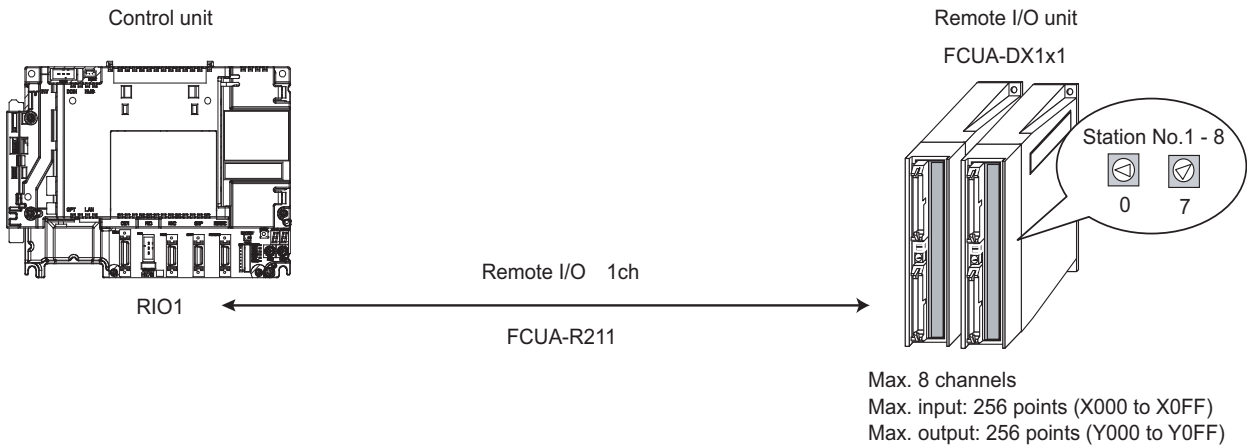

(Note) A remote I/O unit has one or two rotary switch(es) for unit No. setting, which links the device Nos. (with X/Y). The rotary switch setting is as follows, from "0" to "7".

Station No.	Rotary switch
1	0
2	1
3	2
4	3
5	4
6	5
7	6
8	7

When connecting to the operation panel I/O unit

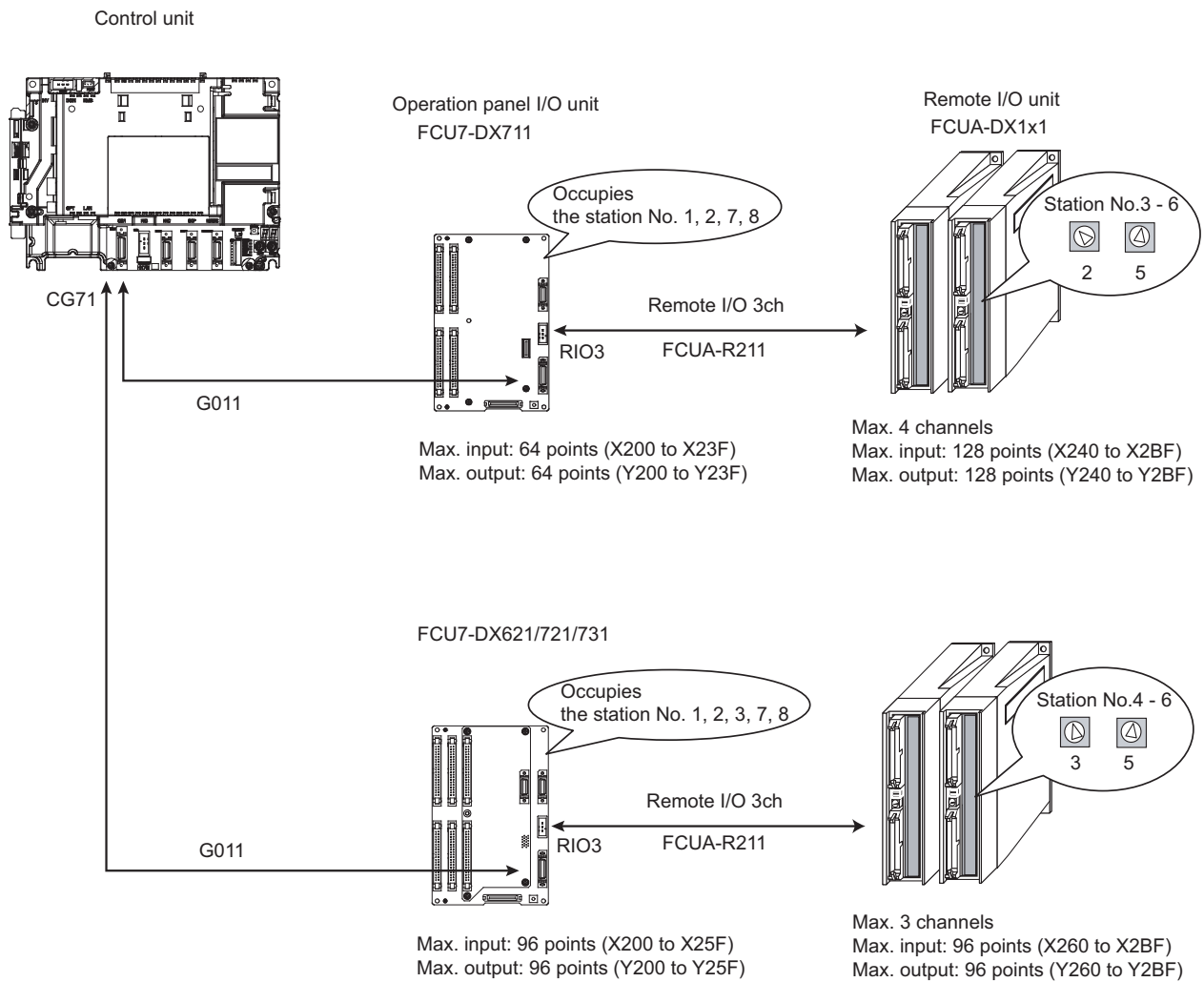

(Note) Operation panel I/O unit occupies the specified Nos. of stations. (Station No. 7 and 8 are reserved for manual pulse generator.)
RIO3 can use either four stations (3rd to 6th) or three stations (4th to 6th) which depends on the operation panel I/O unit type.

4.4.2 Station No. Setting when Using Multiple Remote I/O Units

Multiple remote I/O units can be used, as long as the total No. of occupied stations connected with serial links is eight or less. (three/four or less when connected to the operation panel I/O unit).

Unit type	Number of occupied stations
FCUA-DX101	1
FCUA-DX111	2
FCUA-DX121	2
FCUA-DX141	2

When using multiple remote I/O units, a characteristic station No. must be set for each unit. The FCUA-DX101 unit has one rotary switch, FCUA-DX111, DX121 and DX141 unit have two. Each of these switches must be set to a characteristic station No. within a range of 0 to 7 (2 or 3 to 5 when connected to the operation panel I/O unit).

When connecting directly to the control unit

Setting example 1

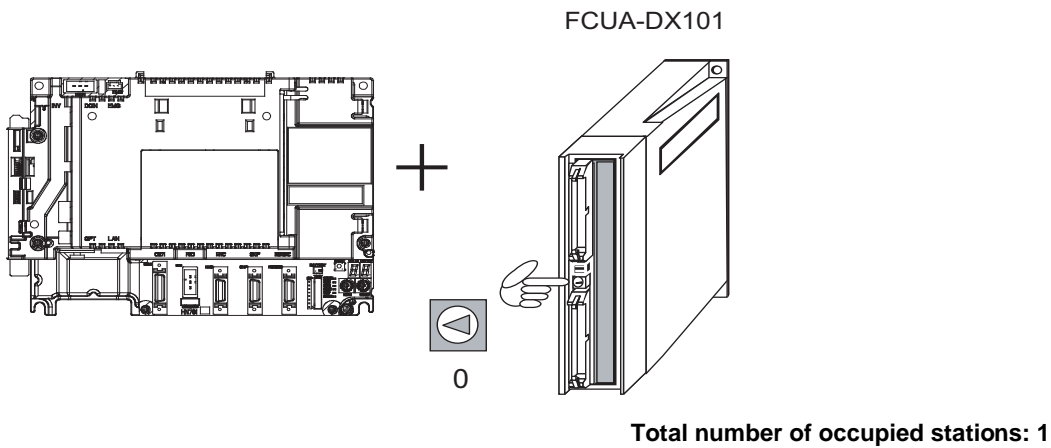

Setting example 2

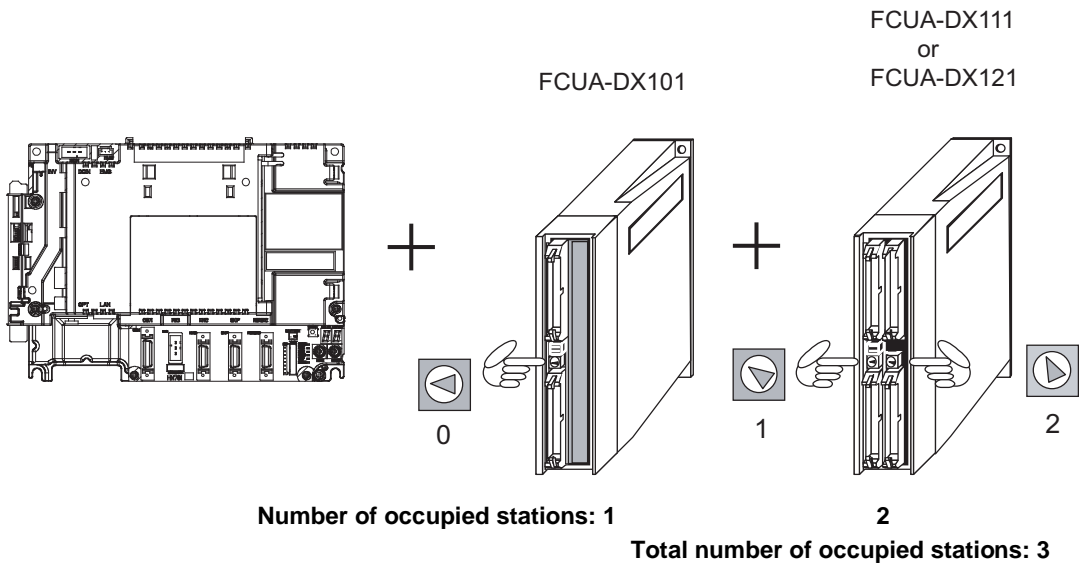

Setting example 3

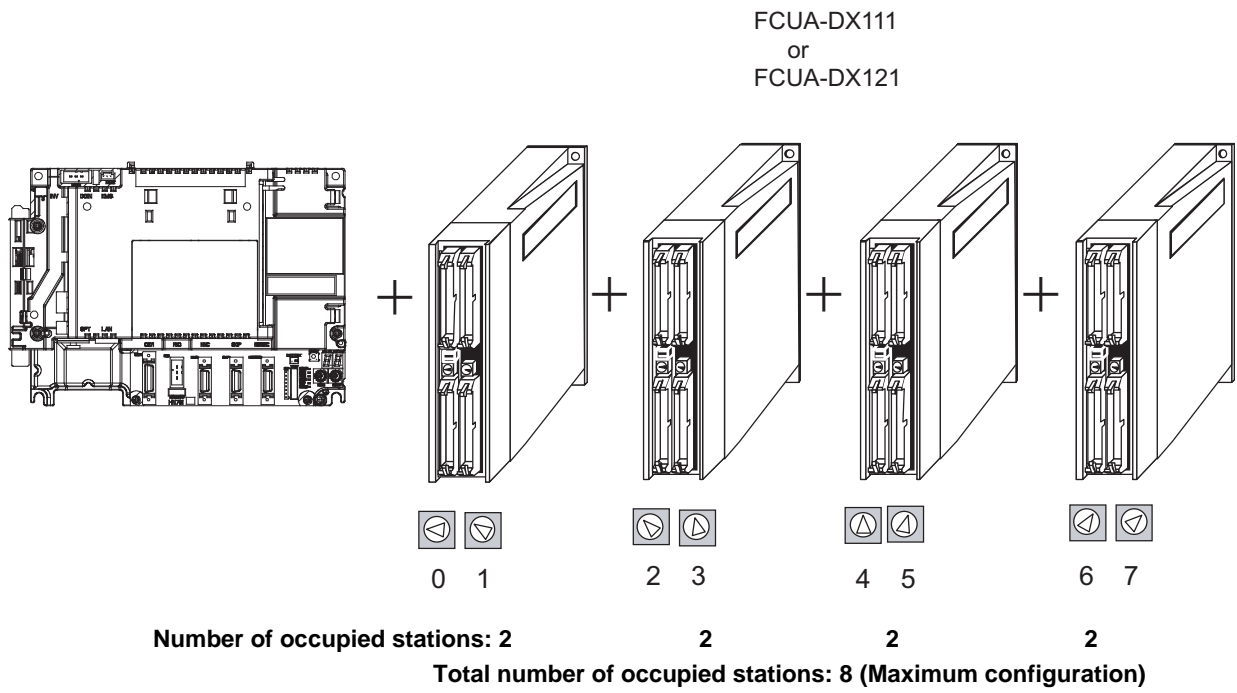

When connecting to the operation panel I/O unit

Station No. 1, 2, 7, 8 (or 1, 2, 3, 7, 8) are occupied by the operation panel I/O unit. (Station No. 7 and 8 are reserved for manual pulse generator.)

The maximum numbers of stations and I/O points assigned to remote I/O unit(s) via RIO3 are as follows.

Operation panel I/O unit type	Max. number of stations (RIO3 connection)	Max. number of I/O points (RIO3 connection)	Remote I/O Rotary switch Setting range
FCU7-DX711	4 stations (No. 3 to 6)	128 points/128 points	2 to 5
FCU7-DX621/721/731	3 stations (No. 4 to 6)	96 points/96 points	3 to 5

Setting example 1

FCU7-DX711

FCUA-DX101

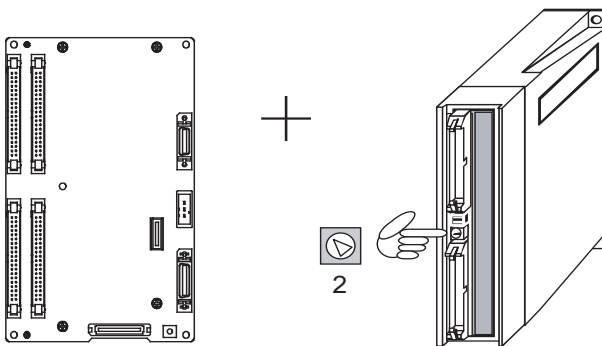

Number of occupied stations: 1

Total number of occupied stations: 1

Setting example 2

FCU7-DX711

FCUA-DX111
or
FCUA-DX121

FCUA-DX111
or
FCUA-DX121

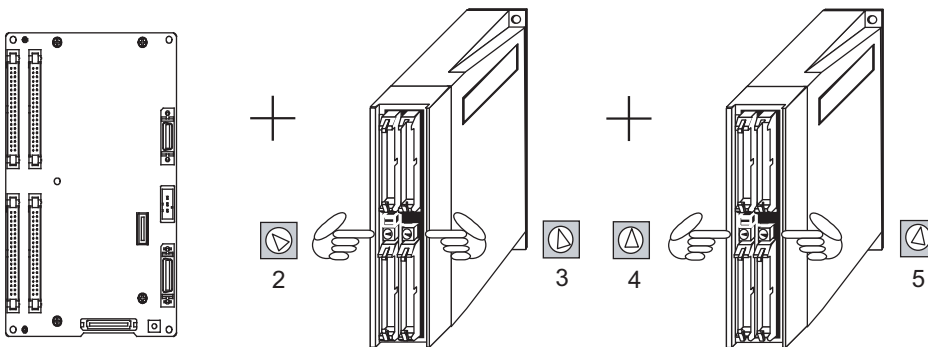

Number of occupied stations: 2

2

Total number of occupied stations: 4 (Maximum configuration)

Setting example 3

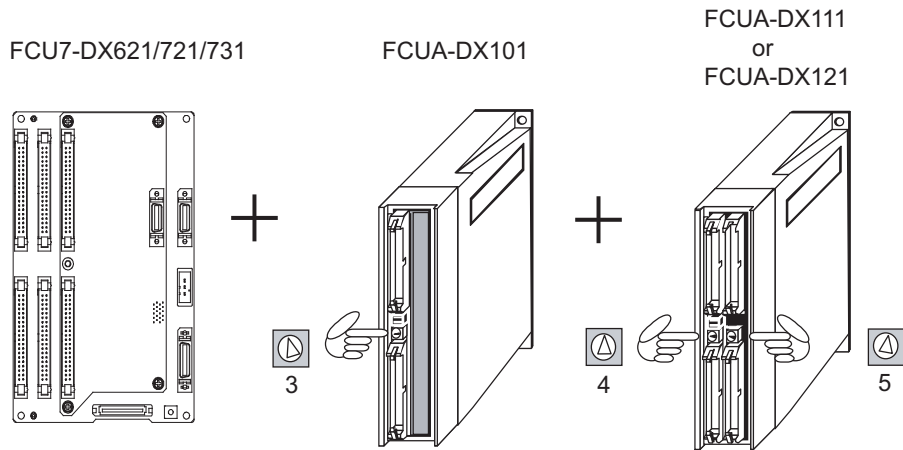

Number of occupied stations: 1

2

Total number of occupied stations: 3 (Maximum configuration)

4.4.3 Connecting FCUA-DX101/141 Unit with Machine Control Signal

Type of machine input/output signal and number of points	Input	Output
		32 points

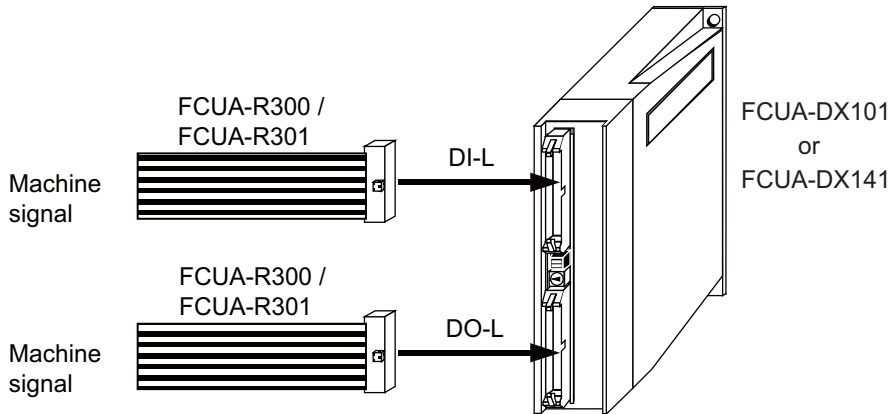

<Outline of connection>

Connection to 0V common (example)

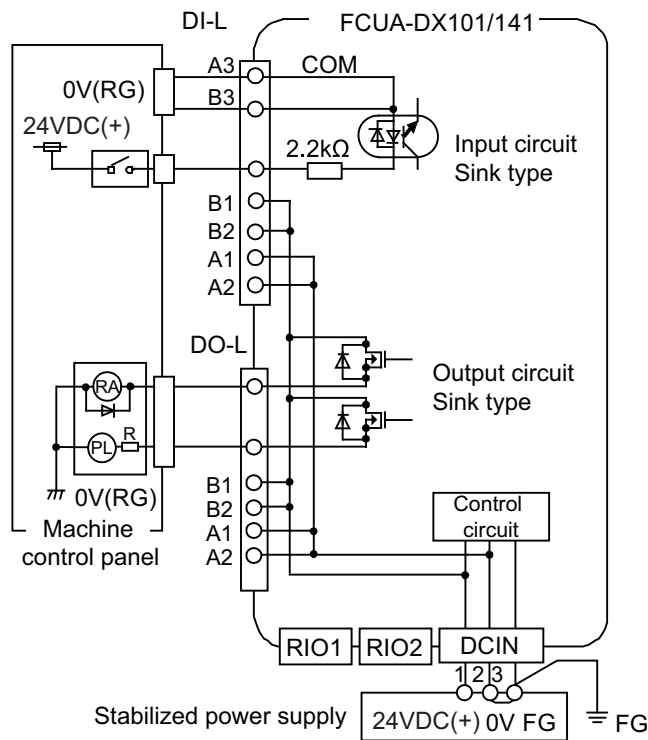

CAUTION

1. Connect the cable to the designated connector. Incorrect connections could damage the device.
2. Do not connect or disconnect the connection cables between each unit while the power is ON.

<Signal assignment>

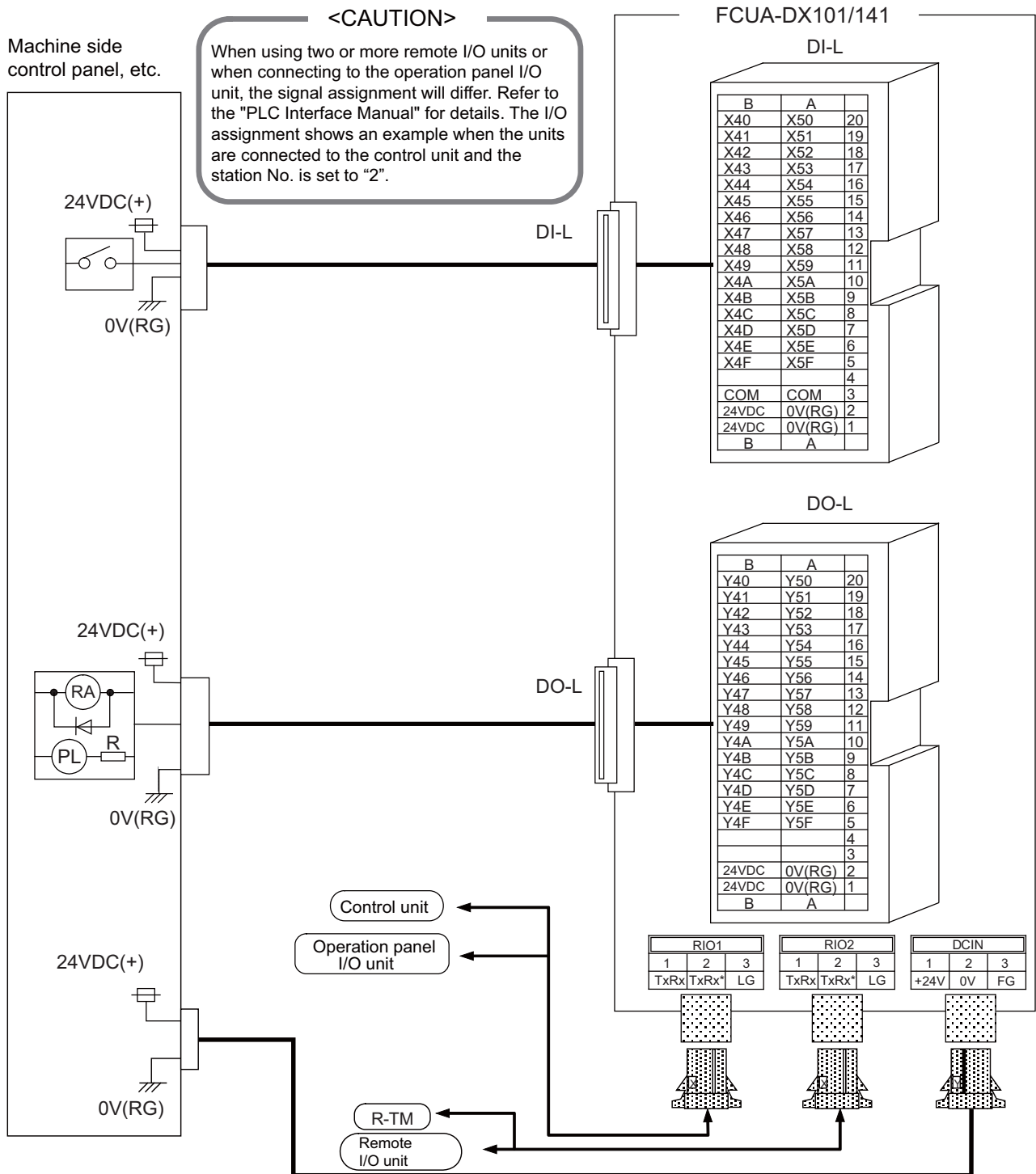

<Adaptive connector>

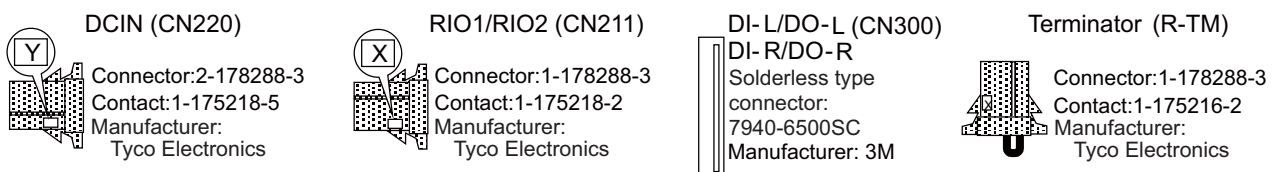

(Note 1) () is the MITSUBISHI original type name.

(Note 2) Refer to "Cable: R-TM Terminator Connector" for the details of R-TM.

4.4.4 Connecting FCUA-DX141 Unit with Analog Input/Output Signal

For the analog input/output signal, connect the FCUA-R031 cable to "AIO". Up to four input points and one output point can be connected for the analog input/output signal. When manufacturing the FCUA-R031 cable, use the FCUA-CS000 connector set (optional, with both ends).

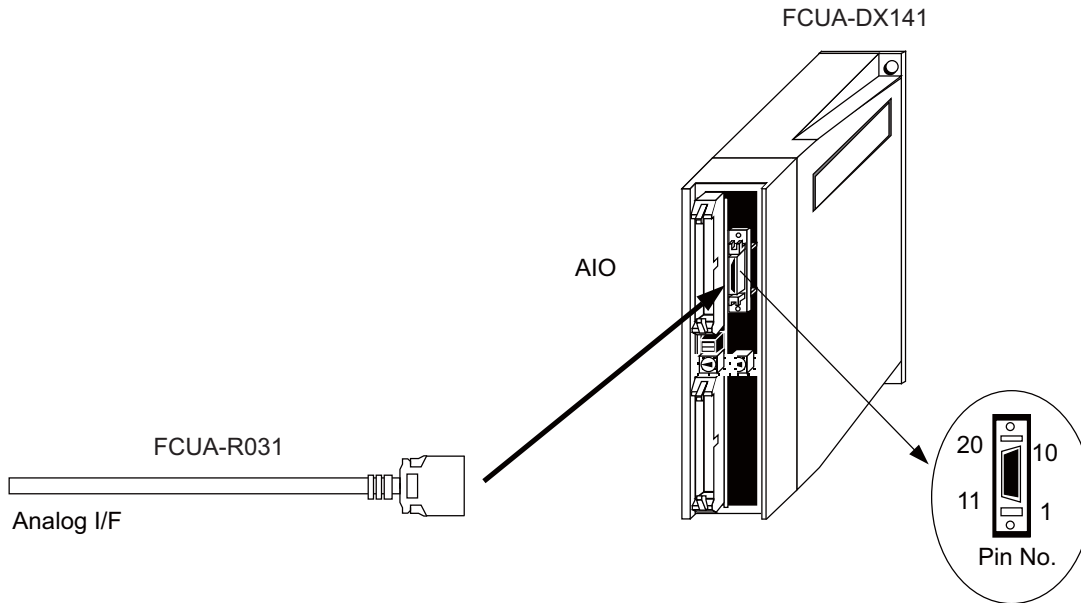

Input/output circuit

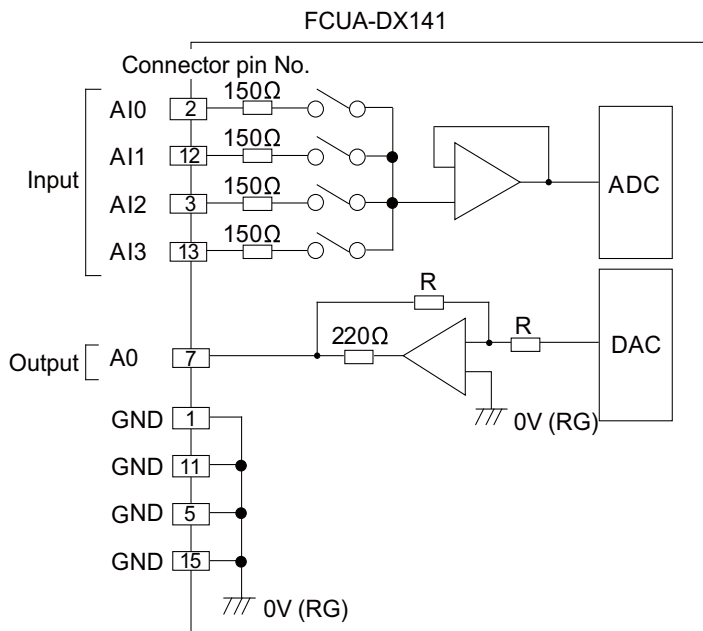

⚠ CAUTION

1. Connect the cable to the designated connector. Incorrect connections could damage the device.
2. Do not connect or disconnect the connection cables between each unit while the power is ON.

4.4.5 Connecting FCUA-DX111 Unit with Machine Control Signal

Type of machine input/output signal and number of points	Input	Output
		64 points

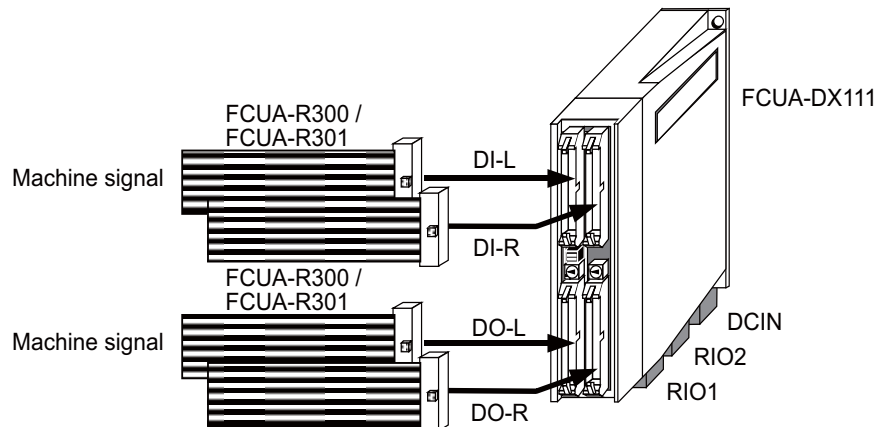

<Outline of connection>

Connection to 0V common (example)

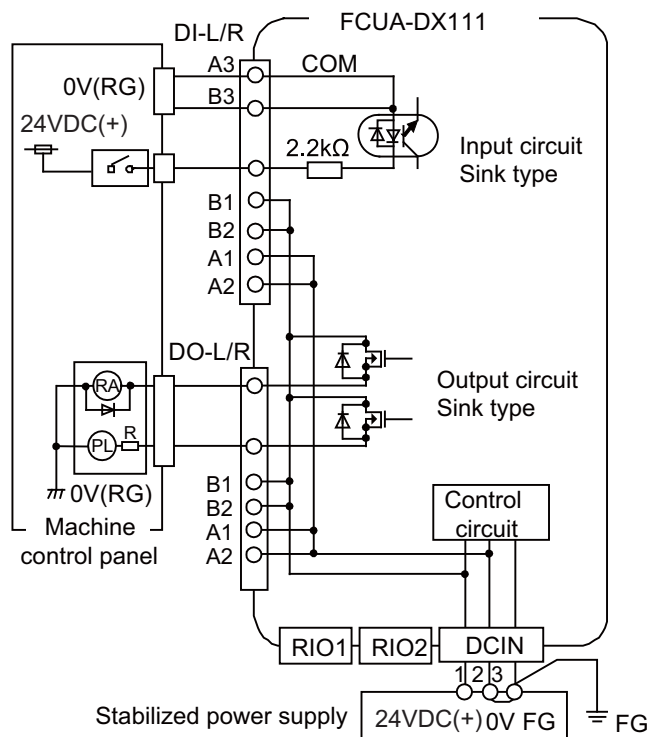

⚠ CAUTION

1. Connect the cable to the designated connector. Incorrect connections could damage the device.
2. Do not connect or disconnect the connection cables between each unit while the power is ON.

<Signal assignment>

<CAUTION>

When using two or more remote I/O units or when connecting to the operation panel I/O unit, the signal assignment will differ. Refer to the "PLC Interface Manual" for details. The I/O assignment shows an example when the station No. is set to "2".

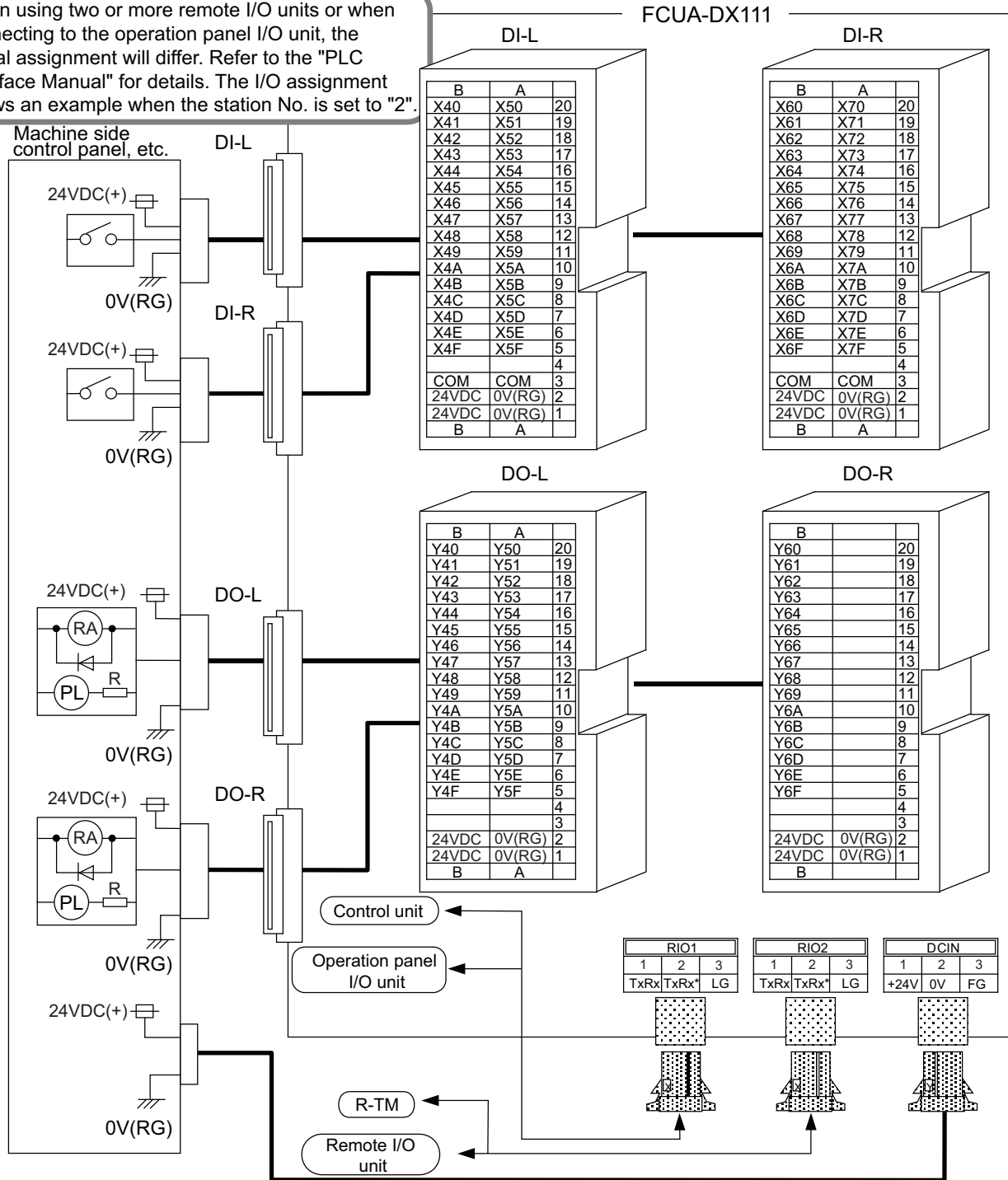

<Adaptive connector>

DCIN (CN220)
 Connector: 2-178288-3
 Contact: 1-175218-5
 Manufacturer: Tyco Electronics

RIO1/RIO2 (CN211)
 Connector: 1-178288-3
 Contact: 1-175218-2
 Manufacturer: Tyco Electronics

DI-L/DO-L (CN300)
DI-R/DO-R
 Solderless type connector:
 7940-6500SC
 Manufacturer: 3M

Terminator (R-TM)
 Connector: 1-178288-3
 Contact: 1-175216-2
 Manufacturer: Tyco Electronics

(Note 1) () is the MITSUBISHI original type name.

(Note 2) Refer to "Cable: R-TM Terminator Connector" for the details of R-TM.

4.4.6 Connecting FCUA-DX121 Unit with Machine Control Signal

Type of machine input/output signal and number of points	Input	Output	Analog output
		64 points	48 points

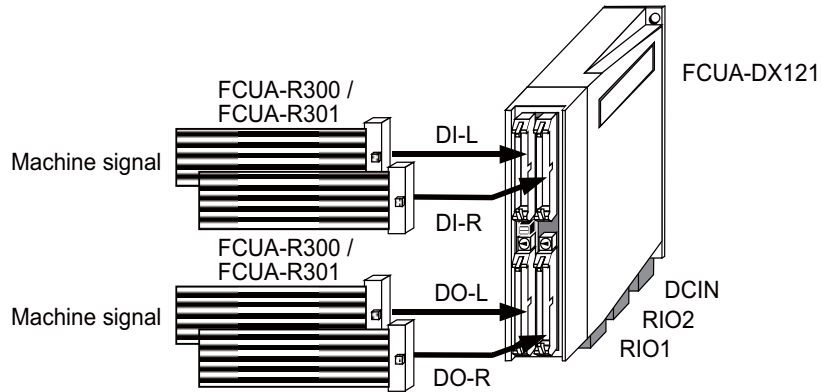

<Outline of connection>

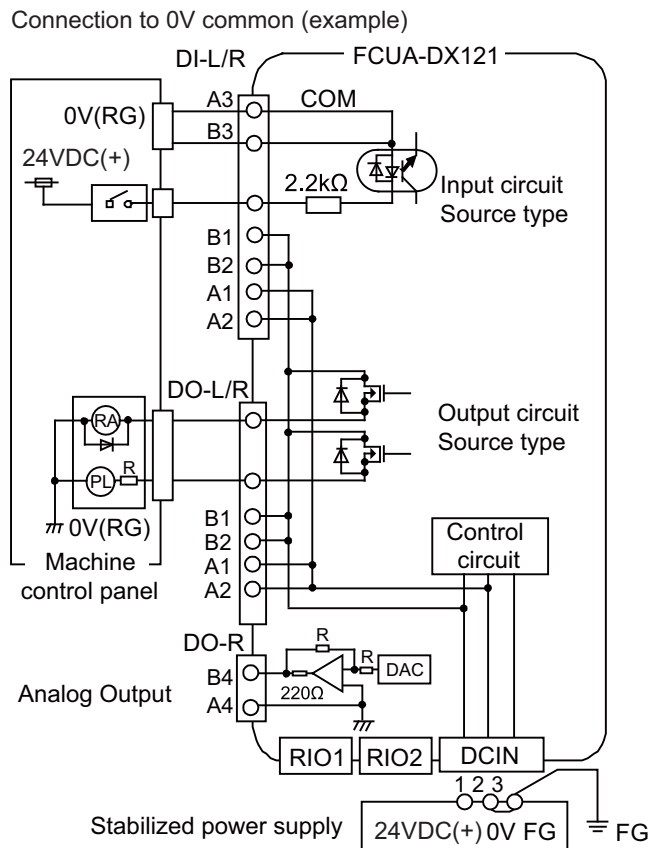

CAUTION

1. Connect the cable to the designated connector. Incorrect connections could damage the device.
2. Do not connect or disconnect the connection cables between each unit while the power is ON.

<Signal assignment>

<CAUTION>

When using two or more remote I/O units or when connecting to the operation panel I/O unit, the signal assignment will differ. Refer to the "PLC Interface Manual" for details. The I/O assignment shows an example when the station No. is set to "2".

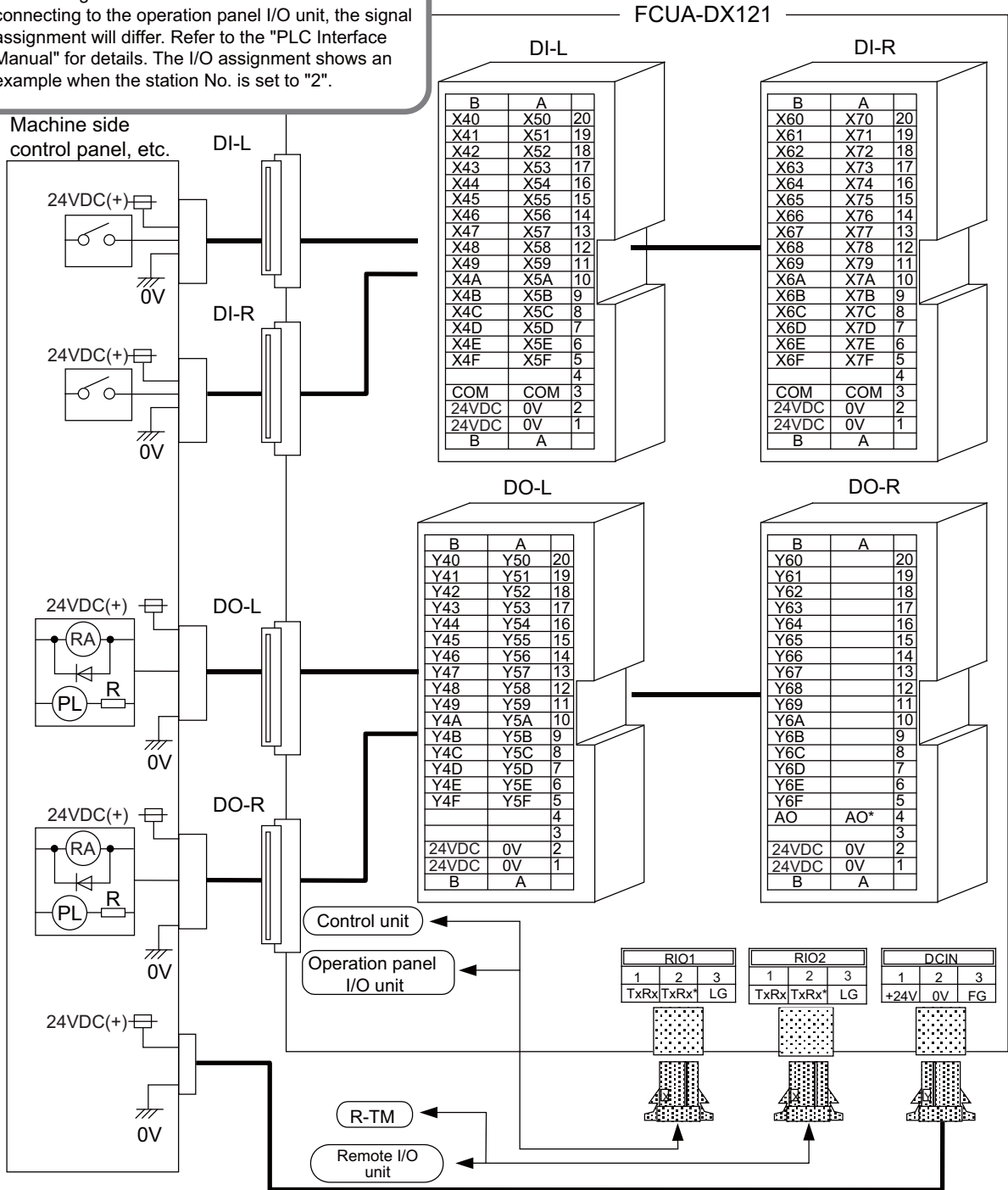

<Adaptive connector>

DCIN (CN220)
 Connector: 2-178288-3
 Contact: 1-175218-5
 Manufacturer: Tyco Electronics

RIO1/RIO2 (CN211)
 Connector: 1-178288-3
 Contact: 1-175218-2
 Manufacturer: Tyco Electronics

DI-L/DO-L (CN300)
DI-R/DO-R
 Solderless type connector:
 7940-6500SC
 Manufacturer: 3M

Terminator (R-TM)
 Connector: 1-178288-3
 Contact: 1-175216-2
 Manufacturer: Tyco Electronics

(Note 1) () is the MITSUBISHI original type name.

(Note 2) Refer to "Cable: R-TM Terminator Connector" for the details of R-TM.

4.5 Connection of MITSUBISHI CNC Machine Operation Panel

(Note) In this chapter "MITSUBISHI CNC Machine operation panel" is shorten to Machine operation panel.

Connect Machine operation panel A to the remote I/O unit I/F of control unit or operation panel I/O unit.

- Machine operation panel A (RIOIN) - cable (FCUA-R211 or SH41) - control unit (RIO1)

- Machine operation panel A (RIOIN) - cable (FCUA-R211 or SH41) - operation panel I/O unit (RIO3)

When supplying power to control unit from Machine operation panel A, the following connection is necessary.

- Machine operation panel A (DCOUT) - cable (G071) - control unit (DCIN)

Connect Machine operation panel B to Machine operation panel A and control unit as follows.

- Machine operation panel B - cable (G460) - Machine operation panel A (SUBP)

- Machine operation panel B - cable (F120) - control unit (EMG)

[When connecting to operation panel I/O unit (RIO3)]

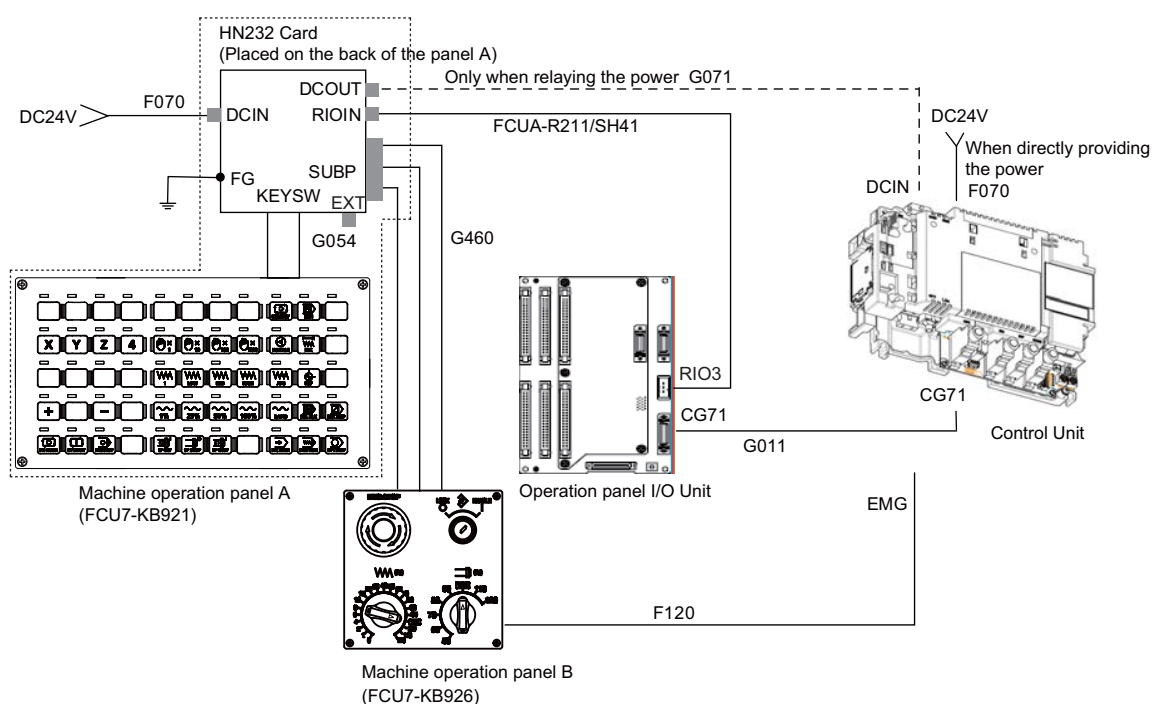

<Related items>

Cable drawing: "Cable: F120 Cable"

"Cable: FCUA-R211 Cable"

"Cable: G460 Cable"

"Cable: SH41 Cable"

"Cable: G011 Cable"

Connector pin assignment: "General Specifications: Operation panel I/O unit" (RIO3 connector/DCIN connector/DCOUT connector/ RIOIN connector/SUBP connector/EMG connector/CG71 connector)

<Software Interface>

Machine operation panel occupies RIO station No. 4 to 6. The device numbers for switch and LED on operation panel are fixed as listed below.

The following lists the devices for using the RIO 1st channel.

Station	Device No.		Detail
	RIO1	RIO3	
1	X00 ~ X1F/Y00 ~ Y1F	X200 ~ X21F/Y200 ~ Y21F	
2	X20 ~ X3F/Y20 ~ Y3F	X220 ~ X23F/Y220 ~ Y23F	
3	X40 ~ X5F/Y40 ~ Y5F	X240 ~ X25F/Y240 ~ Y25F	
4	X60 ~ X7F/Y60 ~ Y7F	X260 ~ X27F/Y260 ~ Y27F	Machine operation panel B (Switch)...16 points vacant
5	X80 ~ X9F/Y80 ~ Y9F	X280 ~ X29F/Y280 ~ Y29F	Machine operation panel A (Key switch/LED)
6	XA0 ~ XBF/YA0 ~ YBF	X2A0 ~ X2BF/Y2A0 ~ Y2BF	Machine operation panel A (Key switch/LED)
7	XC0 ~ XDF/YC0 ~ YDF	-	
8	XE0 ~ XFF/YE0 ~ YFF	-	

Table: Device No. for Machine operation panel

(1) Machine operation panel B (Switch)

Machine operation panel B is equipped with rotary switches (cutting override, spindle override) and a selector switch (memory protection key), and an emergency stop button. Direct wiring connection will be applied to the emergency stop button, and device numbers for other switches are defined as listed below.

(a) Cutting override (6bit)

21 position code list

Setting value	Device No.					
	X60	X61	X62	X63	X64	X65
0	0	0	0	0	0	0
1	1	0	0	0	0	1
2	1	1	0	0	0	0
3	0	1	0	0	0	1
4	0	1	1	0	0	0
5	1	1	1	0	0	1
6	1	0	1	0	0	0
7	0	0	1	0	0	1
8	0	0	1	1	0	0
9	1	0	1	1	0	1
10	1	1	1	1	0	0
11	0	1	1	1	0	1
12	0	1	0	1	0	0
13	1	1	0	1	0	1
14	1	0	0	1	0	0
15	0	0	0	1	0	1
16	0	0	0	1	1	0
17	1	0	0	1	1	1
18	1	1	0	1	1	0
19	0	1	0	1	1	1
20	0	1	1	1	1	0

(b) Spindle override (6bit)

8 position code list

Setting value	Device No.					
	X66	X67	X68	X69	X6A	X6B
0	0	0	0	0	0	Not used
1	0	0	0	0	1	
2	1	1	0	0	0	
3	0	1	0	0	1	
4	0	1	1	0	0	
5	1	1	1	0	1	
6	1	0	1	0	0	
7	0	0	1	0	1	

(c) Memory protection switch (1bit)

Memory protection switch X6C

Spare X6D - X6F

(2) Machine operation panel A (Key switch/LED)

Machine operation panel A is equipped with 55 switches and 55 LEDs.

They are allocated X device and Y device as in the figure below.

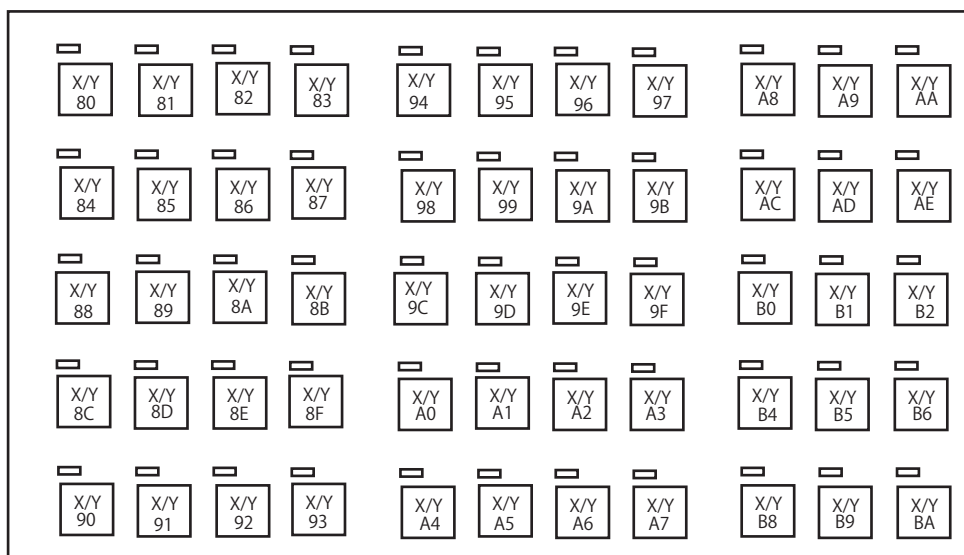

(Note1) If the stations of Machine operation panel and other RIO unit overlap, all the connections of the overlapping RIOs will be invalidated and cannot be used. Stations which do not overlap can be used.

(Note2) Refer to the last page "Table: Device No. for Machine operation panel" for the device No. when connecting to RIO3.





Appendix 1

Cable

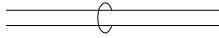
(Note) Symbols for writing cable drawings

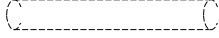
(1)  indicates twisted pair.

(2)  indicates the shield sheath.

(3)  indicates shield clamping to the grounding plate.

(4) In the cable drawings, the partner of the twisted pair cable is given a priority, so the pin No. of the connectors at both ends are not necessary in number of order.

(5) Equivalent parts can be used for the connector, contact and wire material.

Appendix 1.1 Cable Wire and Assembly

(1) Cable wire

The specifications of the wire used for each cable, and the machining methods are shown in this section. When manufacturing the detector cable and battery connection cable, use the recommended wires shown below or equivalent products.

(a) Heat resistant specifications cable

Wire type (special order part)	Finish outer diameter	Sheath material	No. of pairs	Wire characteristics					Flexibility
				Configura tion	Conductive resistor	Withstand voltage	Insulation resistance	Heat resistance temperatu re	
BD20288 Compound 6-pair shielded cable Specification No. Bangishi-17145 (Note 1)	8.7mm	Heat resistant PVC	2 (0.5mm ²)	100 strands/ 0.08mm	40.7Ω/km or less	500VAC/ 1min	1000MΩ/km or more	105C°	70 × 10 ⁴ times or more at R200
			4 (0.2mm ²)	40 strands/ 0.08mm	103Ω/km or less				

(b) General-purpose heat resistant specifications cable

Wire type (special order part)	Finish outer diameter	Sheath material	No. of pairs	Wire characteristics					Flexibility
				Configurat ion	Conductive resistor	Withstand voltage	Insulation resistance	Heat resistance temperatu re	
BD20032 Compound 6-pair shielded cable Specification No. Bangishi-16903 Revision No. 3 (Note 1)	8.7mm	PVC	2 (0.5mm ²)	100 strands/ 0.08mm	40.7Ω/km or less	500VAC/ 1min	1000MΩ/ km or more	60C°	100 × 10 ⁴ times or more at R200
			4 (0.2mm ²)	40 strands/ 0.08mm	103Ω/km or less				

(Note 1) Bando Electric Wire (Contact: +81-48-461-0561 <http://www.bew.co.jp>)

(Note 2) The Mitsubishi standard cable is the (a) Heat resistant specifications cable. For MDS-C1/CH series, (b) or equivalent is used as the standard cable.

Compound 6-pair cable structure drawing

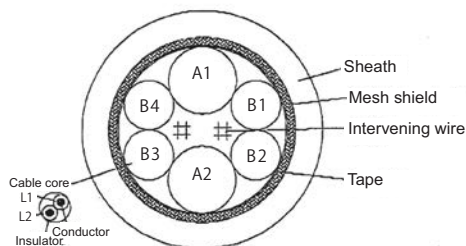

Core identification

Pair No.	Insulator color	
	L1	L2
A1 (0.5mm ²)	Red	White
A2 (0.5mm ²)	Black	White
B1 (0.2mm ²)	Brown	Orange
B2 (0.2mm ²)	Blue	Green
B3 (0.2mm ²)	Purple	White
B4 (0.2mm ²)	Yellow	White

(2) Cable assembly

Assemble the cable with the cable shield wire securely connected to the ground plate of the connector.

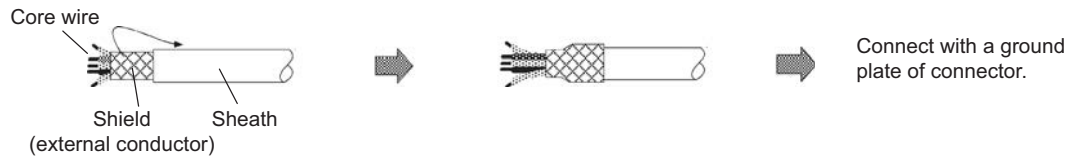

Appendix 1.2 CNP2E-1 Cable

Max. cable length: 30m
Application: Motor side PLG cable
Spindle side accuracy detector
TS5690 cable

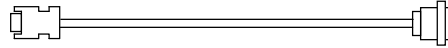

Spindle drive unit side connector
(3M)
Receptacle: 36210-0100PL
Shell kit: 36310-3200-008
(MOLEX)
Connector set: 54599-1019

Spindle motor side connector
(Tyco Electronics)
Connector: 172169-1
Contact: 170363-1(AWG26-22)
170364-1(AWG22-18)

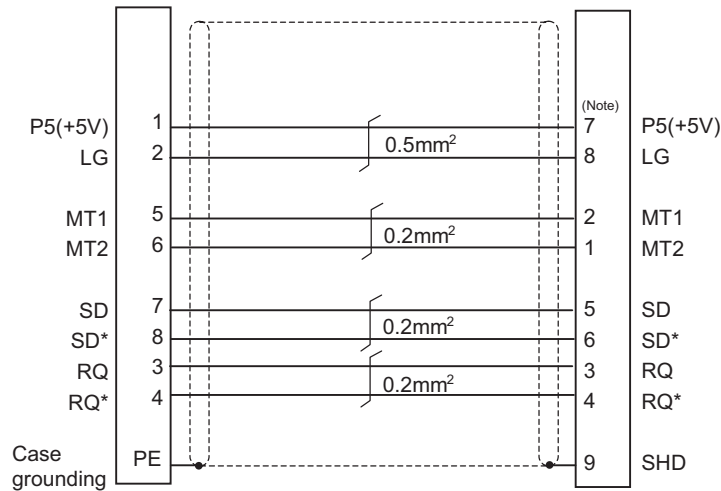

(Note) For the pin "7" or "8", use the contact "170364-1".
For the other pins, use the contact "170363-1".

<Cable connection diagram (for 15m or less)>

Spindle drive unit side connector
(3M)
Receptacle: 36210-0100PL
Shell kit: 36310-3200-008
(MOLEX)
Connector set: 54599-1019

Spindle motor side connector
(Tyco Electronics)
Connector: 172169-1
Contact: 170363-1(AWG26-22)
170364-1(AWG22-18)

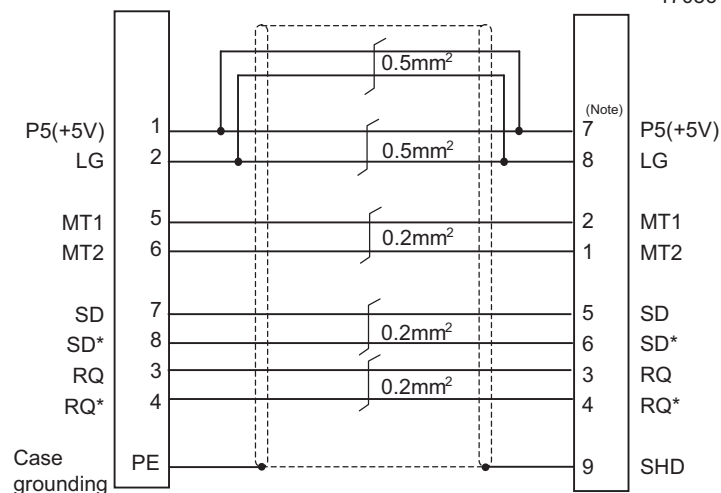

(Note) For the pin "7" or "8", use the contact "170364-1".
For the other pins, use the contact "170363-1".

<Cable connection diagram (for 15m to 30m)>

Appendix 1.3 CNP3EZ-2P/CNP3EZ-3P Cable

Max. cable length: 30m

Application: Spindle side detector cable

OSE-1024 cable

CNP3EZ-2P (Straight)

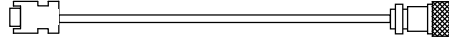

CNP3EZ-3P (Angle)

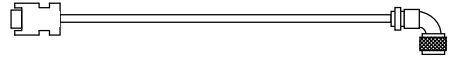

Spindle drive unit side connector
(3M)
Receptacle: 36210-0100PL
Shell kit: 36310-3200-008
(MOLEX)
Connector set: 54599-1019

Spindle motor side connector
(DDK)
Connector: MS3106A20-29S (D190)
Back shell: CE02-20BS-S (straight)
CE-20BA-S (angle)
Clamp: CE3057-12A-3

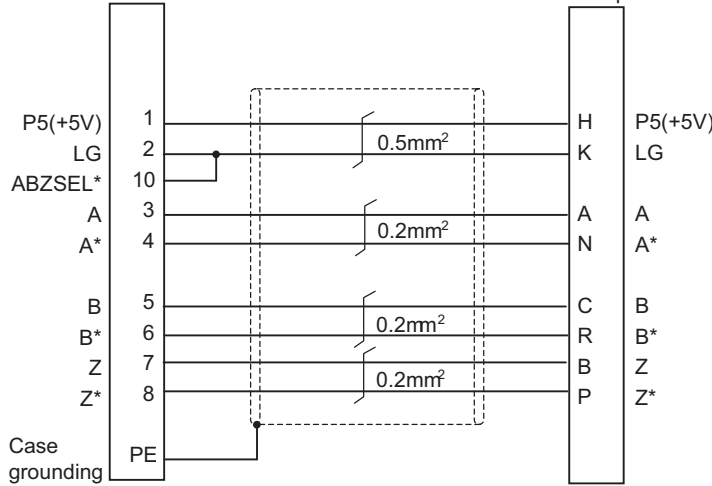

<Cable connection diagram (for 15m or less)>

Spindle drive unit side connector
(3M)
Receptacle: 36210-0100PL
Shell kit: 36310-3200-008
(MOLEX)
Connector set: 54599-1019

Spindle motor side connector
(DDK)
Connector: MS3106A20-29S (D190)
Back shell: CE02-20BS-S (straight)
CE-20BA-S (angle)
Clamp: CE3057-12A-3

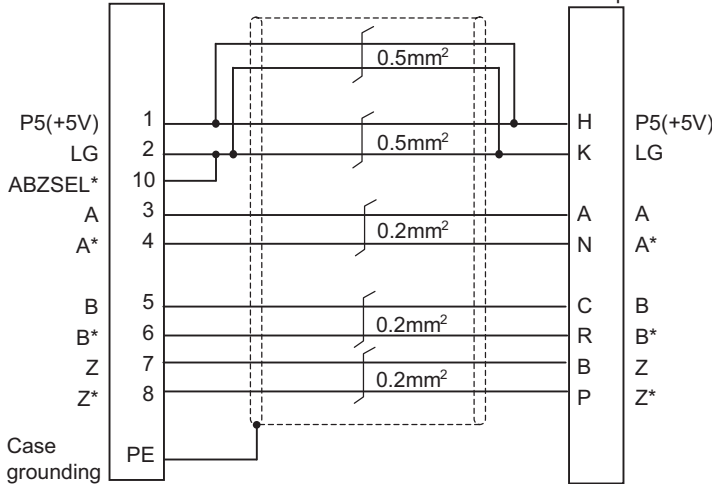

<Cable connection diagram (for 15m to 30m)>

Appendix 1.4 CNV22J-K1P / CNV22J-K2P Cable

Max. cable length: 0.3m

Application: For HF-KP (Servo) Motor side detector relay cable (motor side)

Compatible with only IP65

CNV22J-K1P (load side angle)

CNV22J-K2P (reverse load side angle)



Servo drive unit side connector
 (DDK)
 Plug: CM10-CR10P-M

Servo motor detector/
 Ball screw side detector side connector
 Plug: 1747464-1
 Contact: 1674335-4

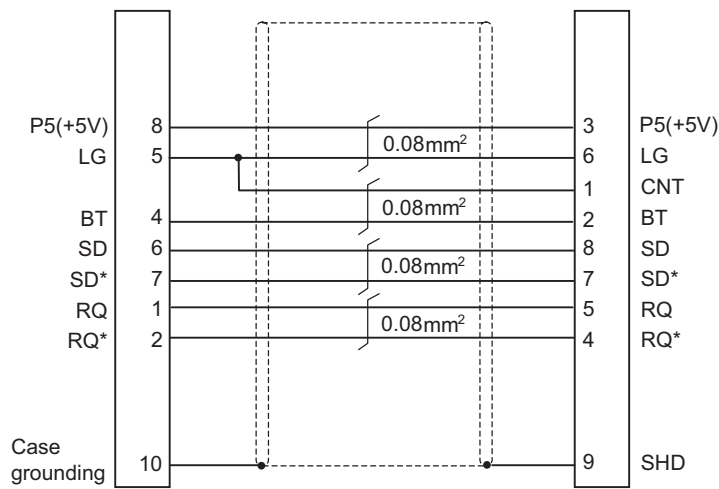

<Cable connection diagram>

Appendix 1.5 CNV2E-8P/CNV2E-9P Cable

Max. cable length: 30m

Application: For HF/HF-H, HF-KP (Tool spindle) Motor side detector cable (for A48/A51/A74N(/A74)) /

For HF-KP (Servo) Motor side detector relay cable (Drive unit side) (CNV2E-8P)

CNV2E-8P (Straight)

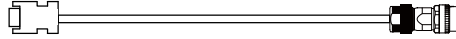

CNV2E-9P (Angle)



Drive unit side connector
(3M)
Receptacle: 36210-0100PL
Shell kit: 36310-3200-008
(MOLEX)
Connector set: 54599-1019

Motor detector/
Ball screw side detector side connector
(DDK)
Plug: CMV1-SP10S-M2 (Straight)
CMV1-AP10S-M2 (Angle)
Contact: CMV1-#22ASC-S1

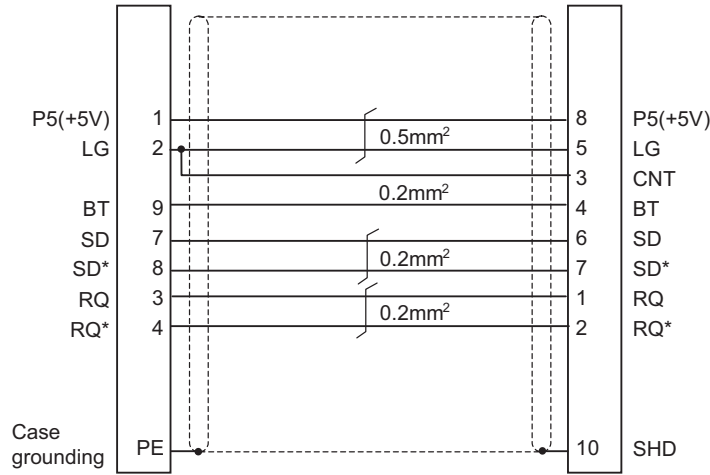

<Cable connection diagram (for 15m or less)>

Drive unit side connector
(3M)
Receptacle: 36210-0100PL
Shell kit: 36310-3200-008
(MOLEX)
Connector set: 54599-1019

Motor detector/
Ball screw side detector side connector
(DDK)
Plug: CMV1-SP10S-M2 (Straight)
CMV1-AP10S-M2 (Angle)
Contact: CMV1-#22ASC-S1

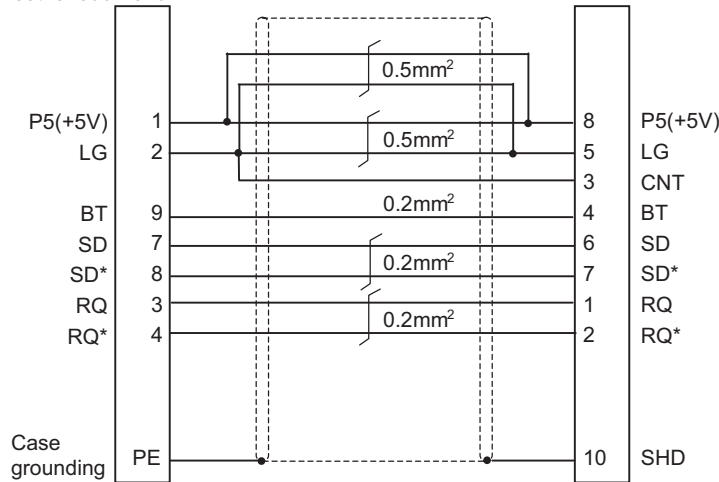

<Cable connection diagram (for 15m to 30m)>

Appendix 1.6 CNV2E-HP Cable

Max. cable length: 30m

Application: MDS-B-HR unit cable

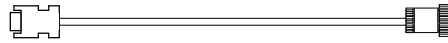

Drive unit side connector
 (3M)
 Receptacle: 36210-0100PL
 Shell kit: 36310-3200-008
 (MOLEX)
 Connector set: 54599-1019

MDS-B-HR unit side connector
 (Hirose Electric)
 Plug: RM15WTP-8S
 Clamp: RM15WTP-CP (10)

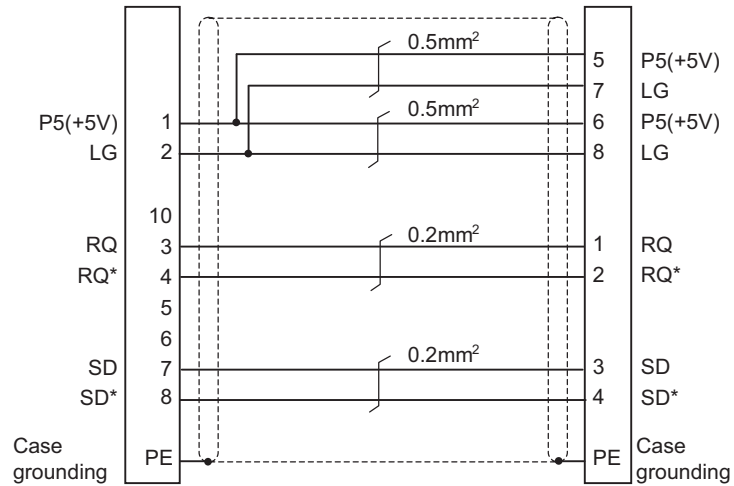

<Cable connection diagram>

Appendix 1.7 CNV2E-K1P / CNV2E-K2P Cable

Max. cable length: 10m

Application: For HF-KP (Servo) Motor side detector cable

Compatible with only IP65

CNV2E-K1P (load side angle)

CNV2E-K2P (reverse load side angle)



Servo drive unit side connector
 (3M)
 Receptacle : 36210-0100PL
 Shell kit : 36310-3200-008
 (MOLEX)
 Connector set : 54599-1019

Servo motor detector connector
 (Tyco Electronics AMP)
 Connector : 1674320-1

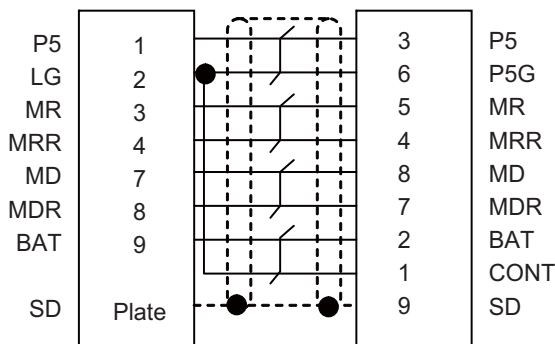

<Cable connection diagram>

Appendix 1.8 DG21 Cable

Max. cable length: 5m

Application: Battery cable (For drive unit - battery unit)

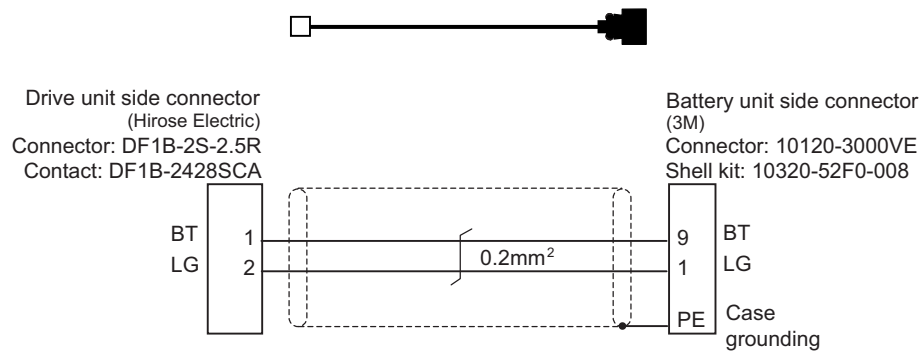

<Cable connection diagram between drive unit and MDS-A-BT/ A6BAT(MR-BAT)(MDS-BTCASE)>

Appendix 1.9 DG22 Cable

Max. cable length: 10m

Application: Battery cable (For drive unit - drive unit)

(Note) This cable is required to supply the power from the battery unit to multiple drive units.

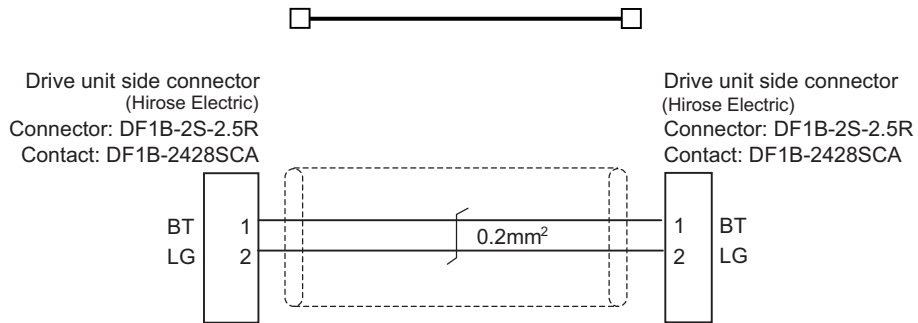

<Cable connection diagram between drive unit and drive unit>

Appendix 1.10 DG23 Cable

Max. cable length: 10m

Application: Battery cable (For drive unit - battery box)

(Note) The battery box side is connected using a bare conductor or a terminal bar.



Drive unit side connector
Connector : DF1B-2S-2.5R
Contact : DF1B-2428SCA

Battery box side

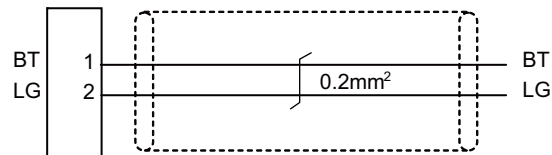

<DG23 cable connection diagram (Connection cable between drive unit and MDS-BTBOX-36)>

Appendix 1.11 DG24 Cable

Max. cable length: 10m

Application: 5V sply/DO output cable (For drive unit - battery box)

(Note) The battery box side is connected using a bare conductor or a terminal bar.

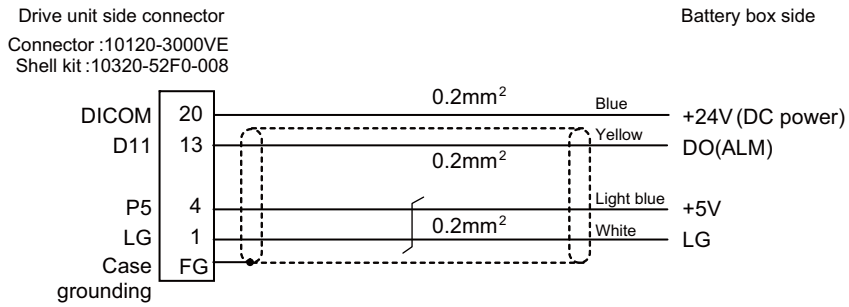
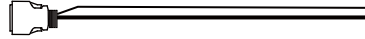

<DG24 cable connection diagram (Connection cable for alarm output between drive unit and MDS-BTBOX-36)>
(For MDS-D2/DH2)

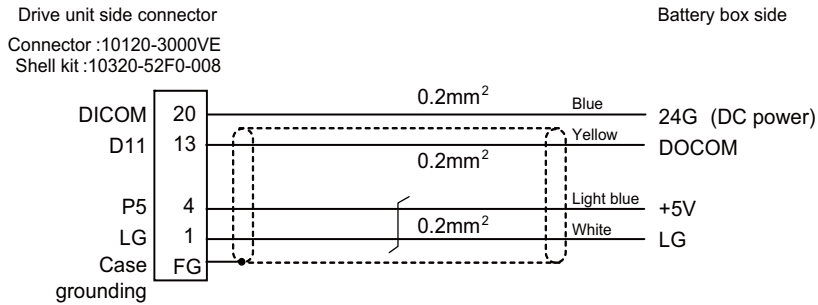

<DG24 cable connection diagram (Connection cable for alarm output between drive unit and MDS-BTBOX-36)>
(For MDS-DM2)

Appendix 1.12 DG25 Cable

Max. cable length: 10m

Application: Battery cable (For drive unit - battery box)

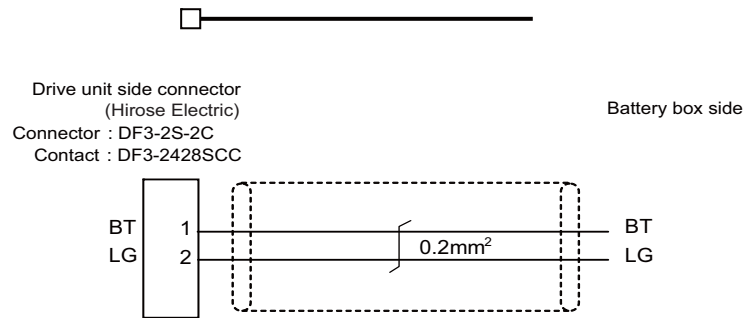

<DG25 cable connection diagram (Connection cable between drive unit and MDS-BTBOX-36)>

Appendix 1.13 F023/F024 Cable

Max. cable length: 20m

Application: Manual Pulse Generator (5V spec)

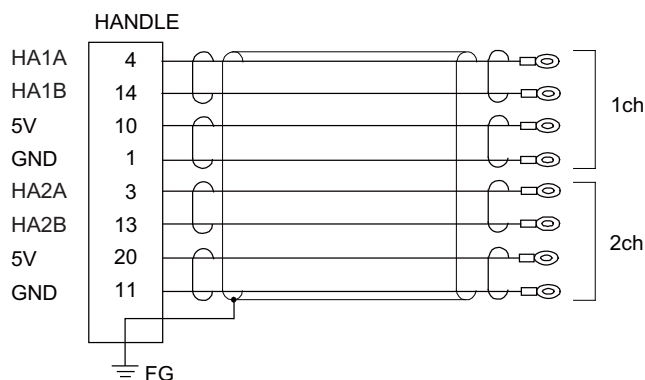
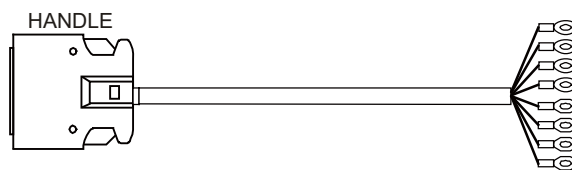

[HANDLE]
 Connector: 10120-3000VE
 Case: 10320-52F0-008
 Recommended manufacturer: 3M

Wire material: UL1061-2464
 AWG22×6P
 Recommended manufacturer: Oki
 Electric Cable

[1ch][2ch]
 Crimp terminal: V1.25-3
 Recommended manufacturer: JST

Cable name	1ch	2ch
F023 cable	○	
F024 cable	○	○
○ : Usable channel		

(Note) Fold the cable shield over the sheath, and wrap copper foil tape over it. Connect the wound copper foil tape to GND plate of the connector.

Appendix 1.14 F034/F035 Cable

Max. cable length: 15m (the maximum length of the cable when connected to the control unit via other units)

Application: RS232C I/F cable (for control unit)

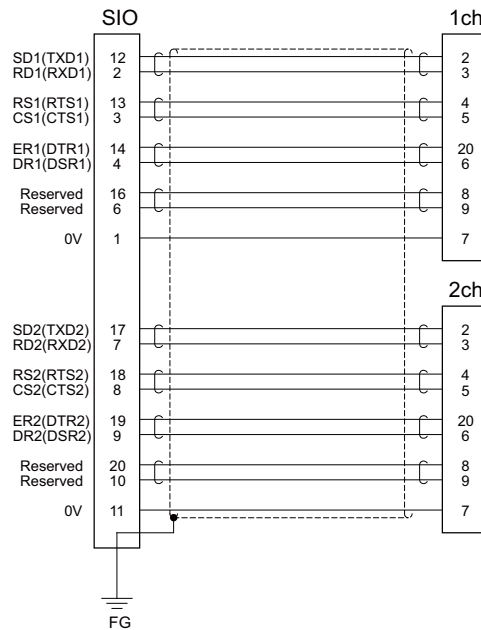
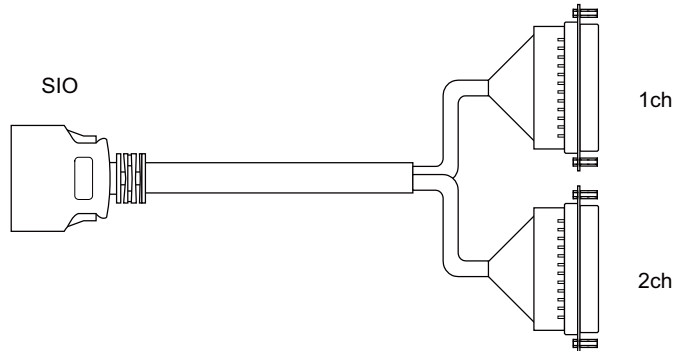

[SIO]
Connector: 10120-3000VE
Case: 10320-52F0-008
Recommended manufacturer: 3M

Wire material: UL1061-2464
AWG24×12P
Recommended manufacturer: Oki
Electric Cable

[1ch][2ch]
Connector: CDB-25S
Contact: CD-SC-111×9
Lock nut: HD-LNA×2
Recommended manufacturer:
Hirose Electric

Cable name	1ch	2ch
F034 cable	○	
F035 cable	○	○
○ : Usable channel		

(Note 1) Fold the cable shield over the sheath, and wrap copper foil tape over it. Connect the wound copper foil tape to GND plate of the connector.

(Note 2) Signal names in parentheses "()" are generally used.

(Note 3) Connect to the serial communication connector of the control unit. Use G031/G032 cable when connecting to the serial communication connector of the display unit.

Appendix 1.15 F070 Cable

Max. cable length: 30m

Application: 24VDC power cable

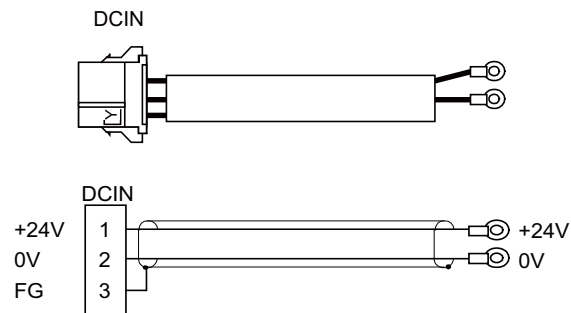

[DCIN]

Connector: 2-178288-3

Contact: 1-175218-5 x3

Recommended manufacturer: Tyco Electronics

Wire material: B-18(19)Ux2SJ-1x9

Recommended manufacturer:

Sumitomo Electric Industries

Crimp terminal: V1.25-3 or V1.25-4x2

Recommended manufacturer: JST

Appendix 1.16 F110 Cable

Max. cable length: 15m

Application: 24VDC power cable for PD25/PD27

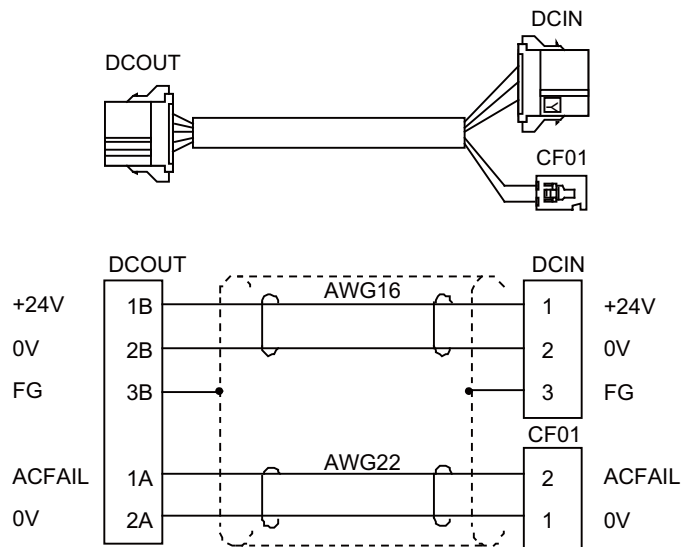

[DCOUT]

Connector: 3-178127-6

Contact:

1-175218-5 (for AWG16) x3,

1-175217-5 (for AWG22) x2

Recommended manufacturer:

Tyco Electronics

Wire material:

UL2464 2x22AWG+2x16AWG SS-95138

Recommended manufacturer: DDK

[DCIN]

Connector: 2-178288-3

Contact: 1-175218-5 x3

Recommended manufacturer:

Tyco Electronics

[CF01]

Connector: 005057-9402

Contact: 0016020103 x2

Recommended manufacturer:

MOLEX

Appendix 1.17 F120 Cable

Max. cable length: 30m

Application: Emergency stop cable

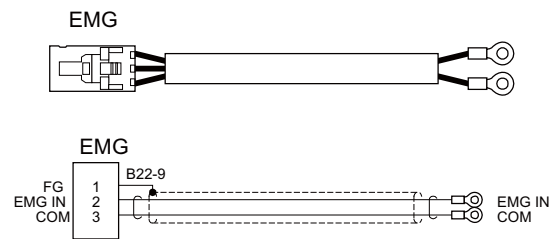

[EMG]

Connector: 005057-9403

Contact: 0016020103 x3

Recommended manufacturer: MOLEX

Wire material: B-22(19)Ux2SJ-1x9

Recommended manufacturer:

Sumitomo Electric Industries

Crimp terminal: V1.25-3 x2

Recommended manufacturer: JST

Appendix 1.18 F170 Cable

Max. cable length: 15m

Application: ON/OFF switch cable for PD25/PD27

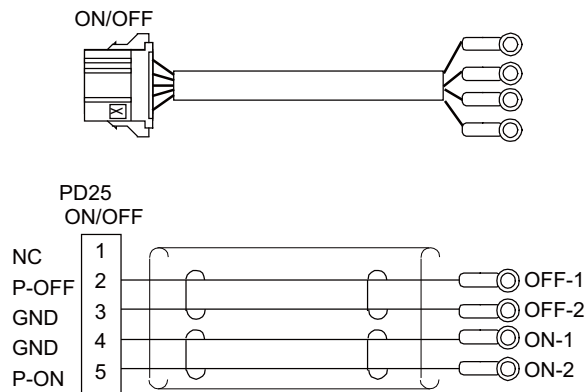

[ON/OFF]

Connector: 1-178288-5

Contact: 1-175218-5

Recommended manufacturer:

Tyco Electronics

Wire material: DPVVSB 3P×0.3mm²

Recommended manufacturer:

Bando Electric Wire

Crimp terminal: V1.25-3 or V1.25-4

Recommended manufacturer: JST

(Note) Select the crimp terminal suitable for the terminal block and switch you use.

Appendix 1.19 F221 Cable

Max. cable length: 30m

Application: Analog output

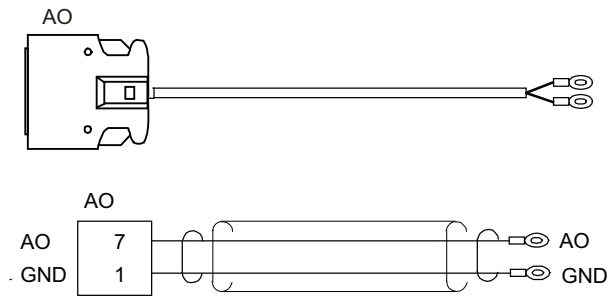

[AO]

Connector: 10120-3000VE

Contact: 10320-52F0-008

Recommended manufacturer: 3M

Wire material: B-22(19)x2SJ-1x9

Recommended manufacturer:

Sumitomo Electric Industries

Crimp terminal: V1.25-3

Recommended manufacturer: JST

(Note 1) Follow the instruction of the machine side in connecting the shield. Do not connect on the base I/O unit side.

(Note 2) Select the crimp terminal suitable for the terminal block you use.

Appendix 1.20 F320/F321 Cable

Max. cable length: 50m

Application: Manual Pulse Generator (12V spec)

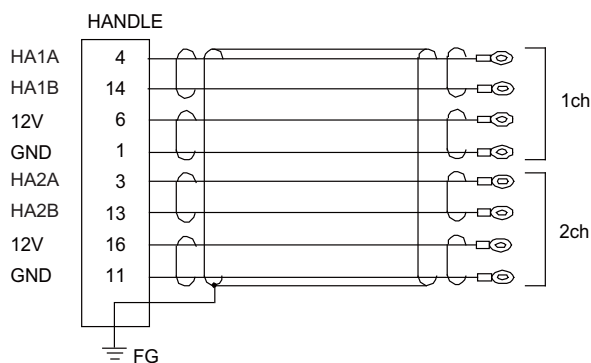
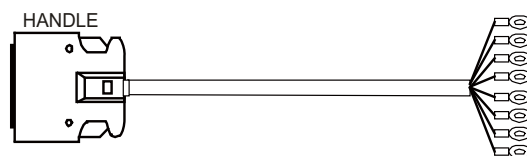

[HANDLE]

Connector: 10120-3000VE

Case: 10320-52F0-008

Recommended manufacturer: 3M

Wire material: UL1061-2464

AWG22x6P

Recommended manufacturer:

Oki Electric Cable

[1ch][2ch]

Crimp terminal: V1.25-3

Recommended manufacturer: JST

Cable name	1ch	2ch
F320 Cable	○	
F321 Cable	○	○
○ : Usable channel		

(Note) Fold the cable shield over the sheath, and wrap copper foil tape over it. Connect the wound copper foil tape to GND plate of the connector.

Appendix 1.21 F351 Cable

Max. cable length: 50m

Application: DI/DO

CG31,CG32,CG33,CG34,CG35,CG36



[CG31, CG32, CG33, CG34, CG35, CG36]

Connector: 7940-6500SC

Strain relief: 3448-7940

Recommended manufacturer: 3M

Wire material: B40-S

Recommended manufacturer:

Oki Electric Cable

(Note) This cable is used to connect the operation panel I/O unit. Select FCUA-R300, which doesn't have strain relief, when connecting to remote I/O unit.

Appendix 1.22 FCUA-R030 Cable

Max. cable length: 20m

Application: SKIP input cable

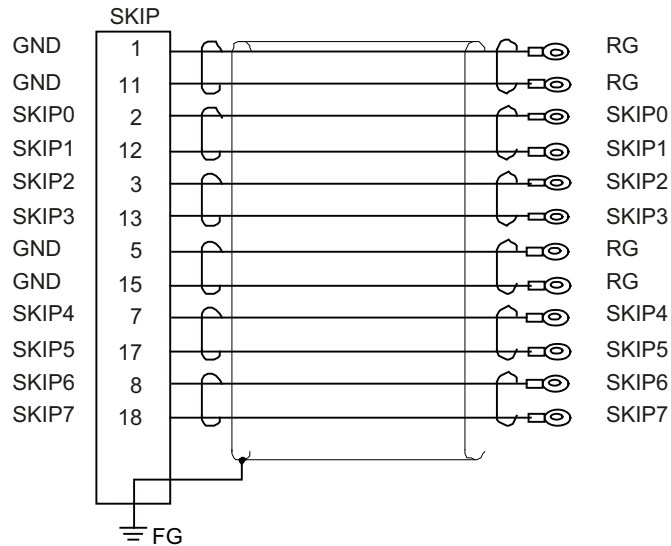
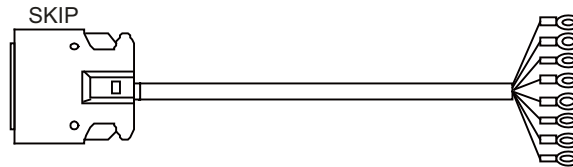

[SKIP]
 Connector: 10120-3000VE
 Case: 10320-52F0-008
 Recommended manufacturer: 3M

Wire material: UL1061-2464
 AWG22×6P
 Recommended manufacturer:
 Oki Electric Cable

Crimp terminal: V1.25-4 ×12
 Recommended manufacturer: JST

(Note) Fold the cable shield over the sheath, and wrap copper foil tape over it. Connect the wound copper foil tape to GND plate of the connector.

Appendix 1.23 FCUA-R031 Cable

Max. cable length: 30m

Application: Analog input/output (for remote I/O unit)

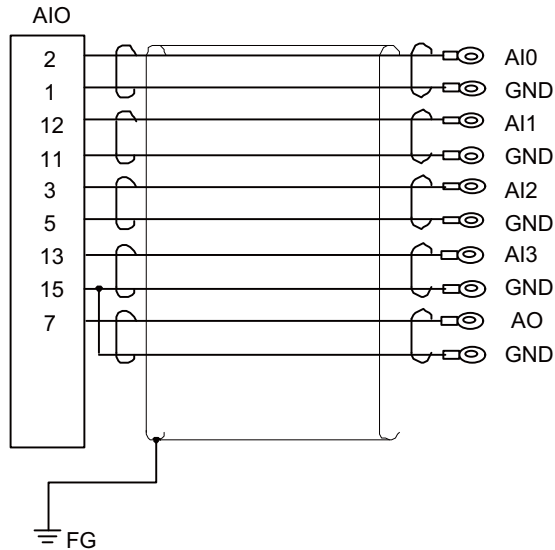
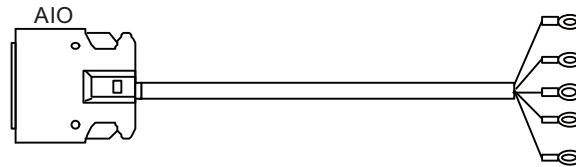

[AIO]
 Connector: 10120-3000VE
 Case: 10320-52F0-008
 Recommended manufacturer: 3M

Wire material: UL1061-2464
 AWG24x6P
 Recommended manufacturer:
 Oki Electric Cable

Crimp terminal: V1.25-3 x10
 Recommended manufacturer: JST

(Note) Fold the cable shield over the sheath, and wrap copper foil tape over it. Connect the wound copper foil tape to GND plate of the connector.

Appendix 1.24 FCUA-R050/R054 Cable

Max. cable length: 30m

Application: Synchronous encoder - control unit

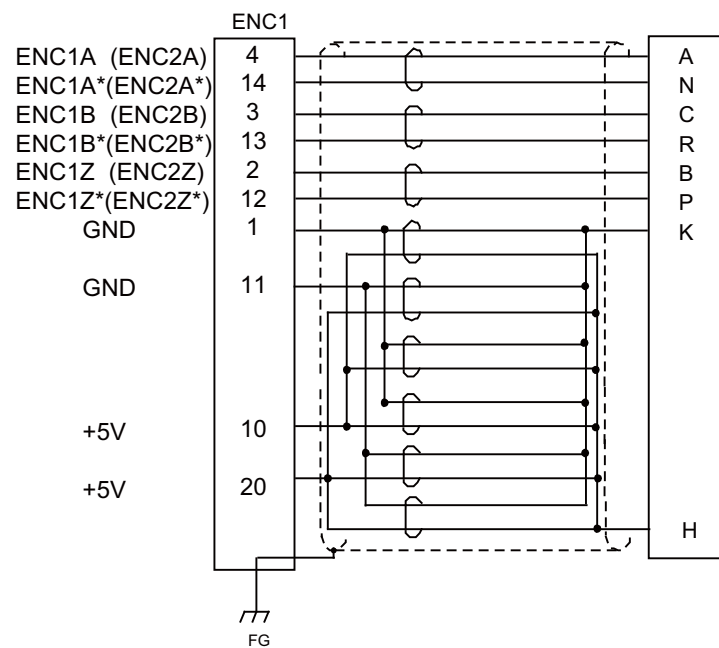
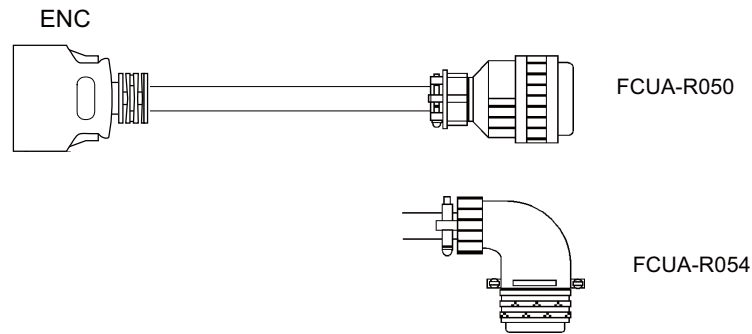

[ENC1]
 Plug: 10120-3000VL
 Shell: 10320-52F0-008
 Recommended manufacturer: 3M

Wire material: UL1061-2464
 AWG24×12P
 Recommended manufacturer:
 Oki Electric Cable

[FCUA-R050 cable]
 Connector: MS3106B20-29S
 Cable clamp: MS3057-12A
 Recommended manufacturer:
 ITT Cannon
 [FCUA-R054 cable]
 Connector: MS3108B20-29S
 Cable clamp: MS3057-12A
 Recommended manufacturer:
 ITT Cannon

(Note) Fold the cable shield over the sheath, and wrap copper foil tape over it. Connect the wound copper foil tape to GND plate of the connector.

Appendix 1.25 FCUA-R211 Cable

Max. cable length: 30m (the maximum length of the cable when connected to the control unit via other units)

Application: Remote I/O (with terminal block)

between remote I/O,

remote I/O-CNC control unit,

remote I/O-Operation panel I/O unit,

remote I/O-MITSUBISHI CNC machine operation panel A

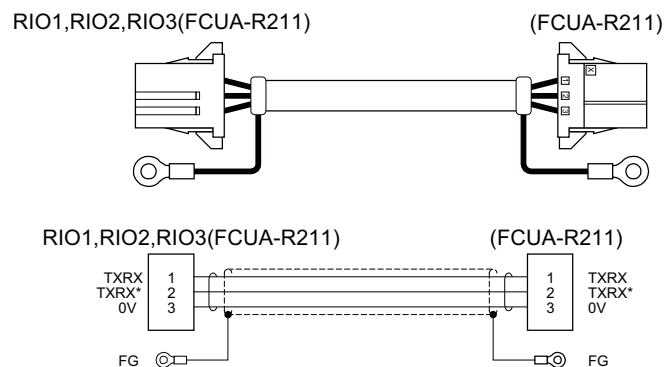

[RIO1, RIO2, RIO3]

Connector: 1-178288-3

Contact: 1-175218-2 x3

Recommended manufacturer:
Tyco Electronics

Wire material:

MVVS 3C×0.5mm² (MIC 3C×0.5mm²)

Recommended manufacturer: Takeuchi Densen

Connector: 1-178288-3

Contact: 1-175218-2 x3

Recommended manufacturer:
Tyco Electronics

(Note) Fold the cable shield over the sheath, and wrap copper foil tape over it. Connect the wound copper foil tape to GND plate of the connector.

Appendix 1.26 FCUA-R300/FCUA-R301 Cable

Type: FCUA-R300
Max. cable length: 50m
Application: DI/DO cable (one side connector)
 (for remote I/O unit)

DI-L/DO-L, DI-R/DO-R

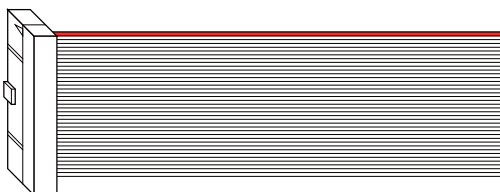

[DI-L/DO-L,DI-R/DO-R]
 Connector: 7940-6500SC
 Recommended manufacturer: 3M

Wire material: B40-S
 Recommended manufacturer:
 Oki Electric Cable

Type: FCUA-R301
Max. cable length: 50m
Application: DI/DO cable (both side connectors)
 (for remote I/O unit)

DI-L/DO-L, DI-R/DO-R

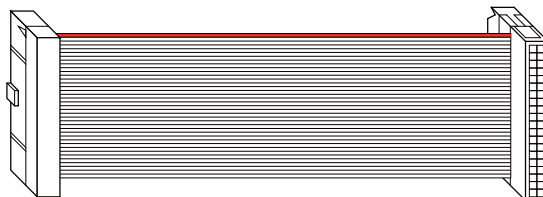

[DI-L/DO-L,DI-R/DO-R]
 Connector: 7940-6500SC
 Recommended manufacturer: 3M

Wire material: B40-S
 Recommended manufacturer:
 Oki Electric Cable

Connector: 7940-6500SC
 Strain relief: 3448-7940
 Recommended manufacturer: 3M

There are two types of cable for the remote I/O unit: FCUA-R300 and FCUA-R301.

The FCUA-R300 cable has one end cut off, and the FCUA-R301 cable is used for connection to the IDEC terminal block BX1F-T40A (Note 1). If a cable longer than 3m is required, use the connector set FCUA-CN300 or FCUA-CS301.

The one-end FCUA-CN300 connector (optional, with one end) includes the DI-L (DI-R) and DO-L (DO-R) connectors. The FCUA-CS301 connector (optional, with both ends) includes the DI-L (DI-R) and DO-L (DO-R) connectors, and two connectors for connection with the terminal block (IDEC).

(Note 1) IDEC I/O terminal BX1F-T40A

Machine control panel,
electric cabinet, etc.

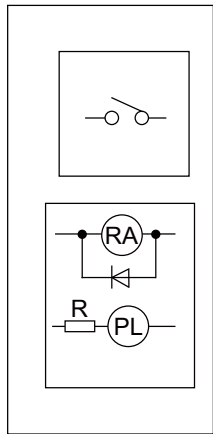

RA : Relay
PL : Pilot lamp

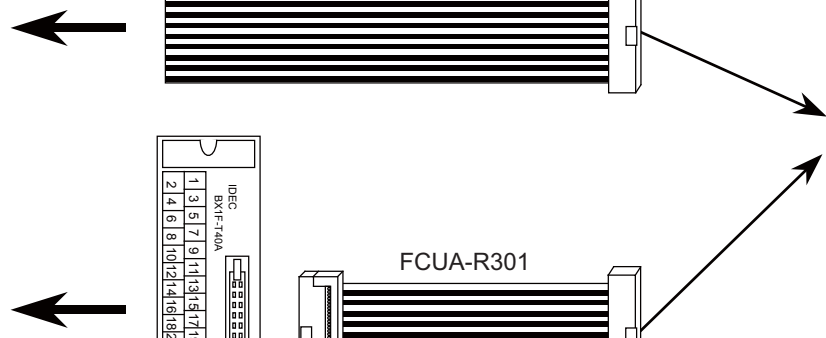
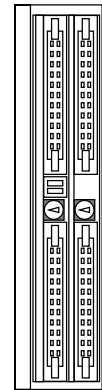
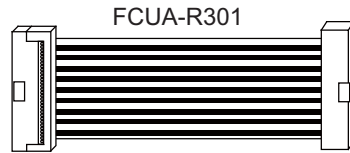
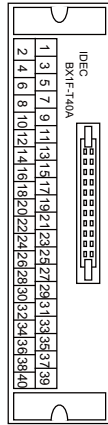
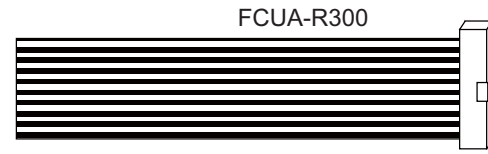

Connector pin correspondence

Terminal block BX1F	FCUA-DX1xx	Terminal block BX1F	FCUA-DX1xx
1	A1	2	B1
3	A2	4	B2
5	A3	6	B3
7	A4	8	B4
9	A5	10	B5
11	A6	12	B6
13	A7	14	B7
15	A8	16	B8
17	A9	18	B9
19	A10	20	B10
21	A11	22	B11
23	A12	24	B12
25	A13	26	B13
27	A14	28	B14
29	A15	30	B15
31	A16	32	B16
33	A17	34	B17
35	A18	36	B18
37	A19	38	B19
39	A20	40	B20

Appendix 1.27 G011 Cable

Max. cable length: 0.5m

Application: Connection between NC unit and operation panel I/O unit

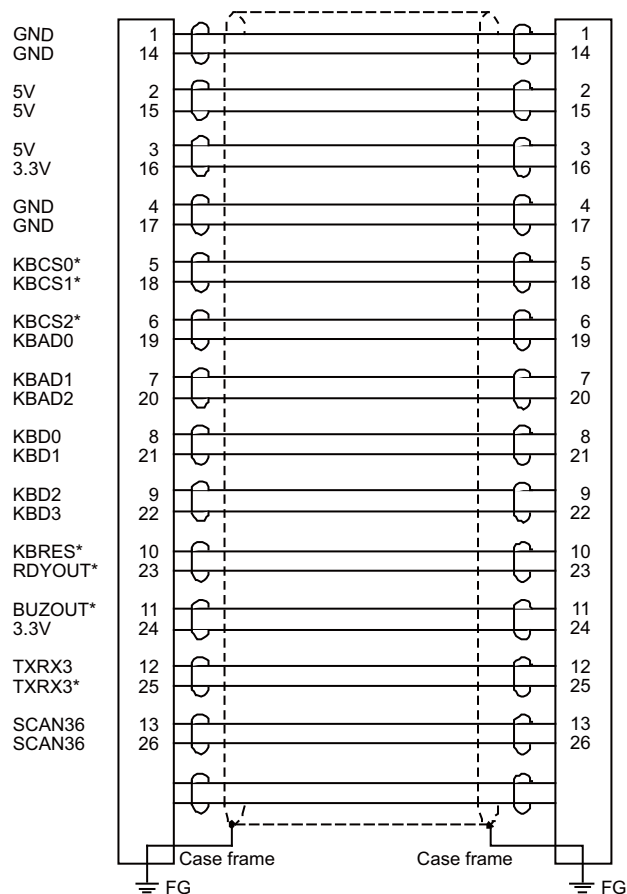
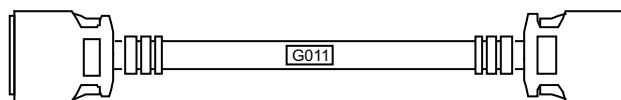

[CG71]

Connector: 10126-3000VE

Case: 10326-52F0-008

Recommended manufacturer: 3M

Wire material: UL20276 AWG28×13P

Recommended manufacturer:

Toyokuni Electric Cable

(Note) Fold the cable shield over the sheath, and wrap copper foil tape over it. Connect the wound copper foil tape to GND plate of the connector.

Appendix 1.28 G023/G024 Cable

Max. cable length: 20m (the maximum length of the cable when connected to the control unit via other units)

Application: Manual Pulse Generator cable (5V)
(for connection to control unit)

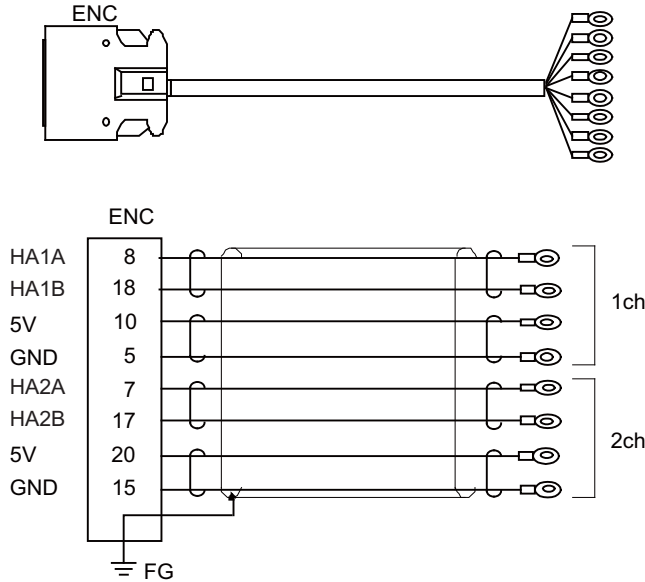

[ENC]

Connector: 10120-3000VE

Case: 10320-52F0-008

Recommended manufacturer: 3M

Wire material:

UL1061-2464 AWG22×6P

Recommended manufacturer:

Oki Electric Cable

[1ch][2ch]

Crimp terminal: V1.25-3 x8

Recommended manufacturer: JST

Cable name	1ch	2ch
G023 cable	○	
G024 cable	○	○
○ : Usable channel		

(Note) Fold the cable shield over the sheath, and wrap copper foil tape over it. Connect the wound copper foil tape to GND plate of the connector.

Appendix 1.29 G071 Cable

Max. cable length: 0.5m

Application: 24VDC relay cable for MITSUBISHI CNC machine operation panel

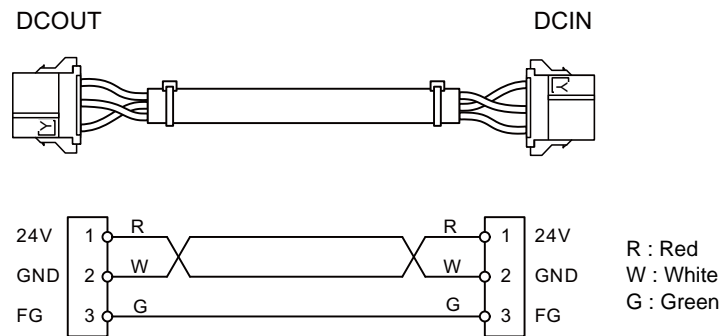

[DCOUT]

Connector: 2-178288-3

Contact: 1-175218-5 x 3

Recommended manufacturer: Tyco
Electronics

Wire material: UL1264 AWG16
(Red, White, Green)

[DCIN]

Connector: 2-178288-3

Contact: 1-175218-5 x 3

Recommended manufacturer: Tyco
Electronics

(Note) These cables are available only when wired to a same control panel.

Appendix 1.30 G300 Cable

Max. cable length: 10m

Application: LAN cross cable (Shielded cable is recommended when the length will be 1m or more)

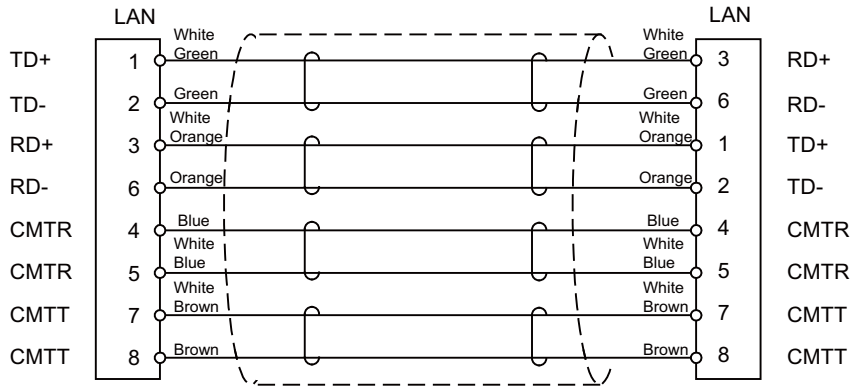
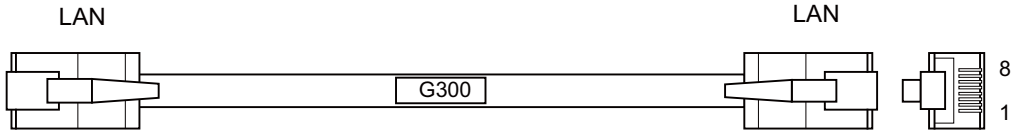

[LAN]

Connector: 5-558530

Recommended manufacturer:

Tyco Electronics

Wire material: LAN category 5 twisted pair x 4P

Appendix 1.31 G301 Cable

Max. cable length: 1m

Application: LAN straight cable (Shielded cable is recommended when the length will be 1m or more)

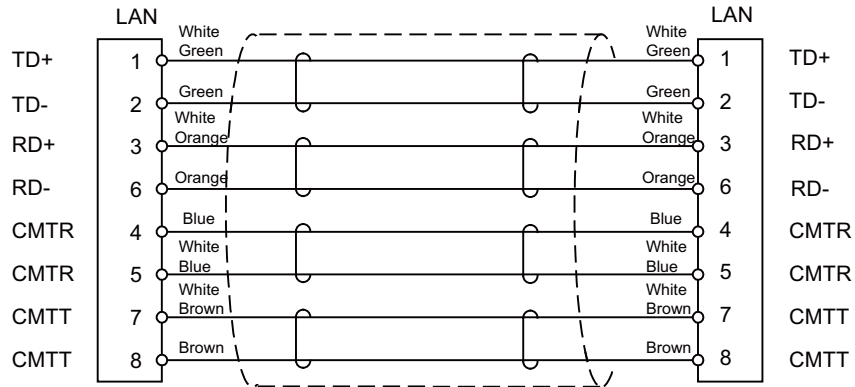
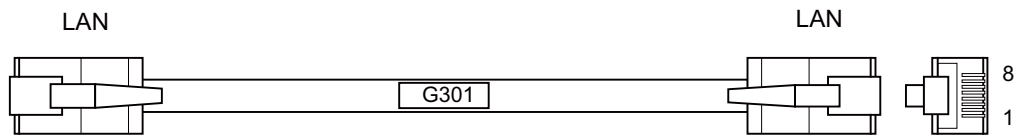

[LAN]

Connector: 5-558530

Recommended manufacturer:

Tyco Electronics

Wire material: LAN category 5 twisted pair x 4P

Appendix 1.32 G380 Cable

Max. cable length: 30m

Application: Optical communication cable

for wiring between drive units (outside panel)

for optical communication repeater unit

Use when the cable length is 10m or more to 30m or less.

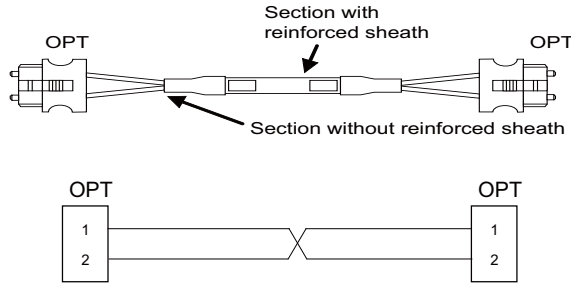

[OPT]

Connector: CF-2D101-S

Recommended manufacturer:
Japan Aviation Electronics

Wire material:

Hard clad type PCF optic cable

Recommended manufacturer:
Oki Electric Cable

Cable	Minimum bending radius: R
2-core cable (section with reinforced sheath)	50mm
2-core cable (section without reinforced sheath)	25mm

- (Note 1) Binding the cables too tight with tie-wraps could result in an increased loss or a disconnection. Use a cushioning material such as a sponge or rubber when bundling the cables and fix so that the cables do not move. Recommended clamp material: CKN-13SP KITAGAWA INDUSTRIES.
- (Note 2) Never bundle the cables with vinyl tape. The plasticizing material in the vinyl tape could cause the PCF cable reinforced sheath to damage.
- (Note 3) Loop the excessive cable with twice or more than the minimum bending radius.

Appendix 1.33 G395 Cable

Max. cable length: 10m

Application: Optical communication cable
 for wiring between drive units (outside panel)
 for wiring between NC-drive units

Use when wiring outside of the panel with a cable of 10m or less.

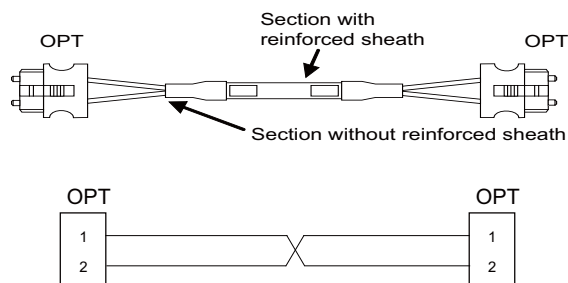

[OPT]
 Connector: PF-2D103
 Recommended manufacturer:
 Japan Aviation Electronics

Wire material: ESCA Premium
 Recommended manufacturer:
 MITSUBISHI RAYON

Cable	Minimum bending radius: R
2-core cable (section with reinforced sheath)	50mm
2-core cable (section without reinforced sheath)	30mm

- (Note 1) Binding the cables too tight with tie-wraps could result in an increased loss or a disconnection. Use a cushioning material such as a sponge or rubber when bundling the cables and fix so that the cables do not move. Recommended clamp material: CKN-13SP KITAGAWA INDUSTRIES.
- (Note 2) Never bundle the cables with vinyl tape. The plasticizing material in the vinyl tape could cause the POF cable to break.
- (Note 3) Loop the excessive cable with twice or more than the minimum bending radius.

Appendix 1.34 G396 Cable

Max. cable length: 10m

Application: Optical communication cable

for wiring between drive units (inside panel)

Use when wiring in the panel with a cable of 10m or less.

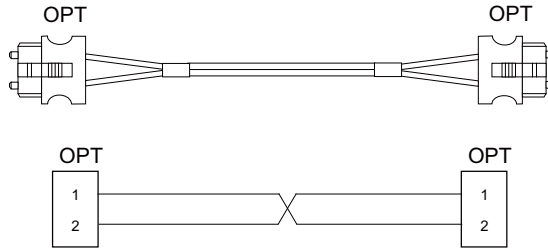

[OPT]

Connector: PF-2D103

Recommended manufacturer:

Japan Aviation Electronics

Wire material: ESCA Premium

Recommended manufacturer:

MITSUBISHI RAYON

Cable	Minimum bending radius: R
2-core parallel cord	30mm

- (Note 1) Binding the cables too tight with tie-wraps could result in an increased loss or a disconnection. Use a cushioning material such as a sponge or rubber when bundling the cables and fix so that the cables do not move. Recommended clamp material: CKN-13SP KITAGAWA INDUSTRIES.
- (Note 2) Never bundle the cables with vinyl tape. The plasticizing material in the vinyl tape could cause the POF cable to break.
- (Note 3) Loop the excessive cable with twice or more than the minimum bending radius.

Appendix 1.35 G460 Cable

Max. cable length: 0.5m

Application: Cable between MITSUBISHI CNC machine operation panel A and MITSUBISHI CNC machine operation panel B

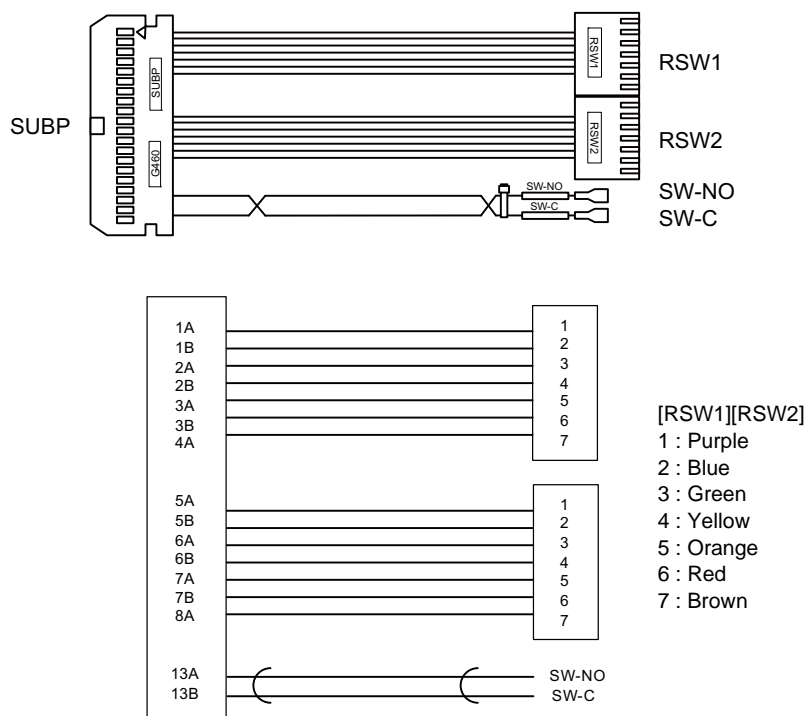

[SUBP]

Connector: HIF3BA-40D-2.54C
Contact: HIF3-2428SC x 16
Recommended manufacturer: Hirose Electric

Wire material: UL1007 AWG24
(Red, Black)

[RSW1][RSW2]

Connector with cable : ACX011-705 x 2
Contact: 1-175218-5 x 3
Recommended manufacturer: Fuji Electric

[SW-NO][SW-C]

Connector: STO-01T-110N
Recommended manufacturer: JST

(Note) Coat the connector [SW-NO][SW-C] with an insulation.

Appendix 1.36 MR-BKS1CBL-A1-H / MR-BKS1CBL-A2-H Cable

Max. cable length: 10m

Application: <200V Series> Brake cable for HF-KP

MR-BKS1CBL-A1-H (load side angle)

MR-BKS1CBL-A2-H (reverse load side angle)



Servo motor brake connector
 (Japan Aviation Electronics)
 Connector: JN4FT02SJ1
 Hood, Socket insulator,
 Bushing and Ground nut
 Contact: ST-TMH-S-C1B-100(A534G)
 Crimp tool: CT160-3TMH5B

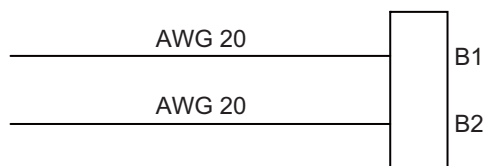

<Cable connection diagram>

Appendix 1.37 MR-PWS1CBL-A1-H / MR-PWS1CBL-A2-H Cable

Max. cable length: 10m

Application: <200V Series> Power cable for HF-KP

MR-PWS1CBL-A1-H (load side angle)

MR-PWS1CBL-A2-H (reverse load side angle)

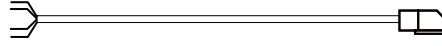

Servo motor power supply connector
(Japan Aviation Electronics)

Connector: JN4FT04SJ1

Hood, Socket insulator,

Bushing and Grand nut

Contact: ST-TMH-S-C1B-100(A534G)

Crimp tool: CT160-3TM5B

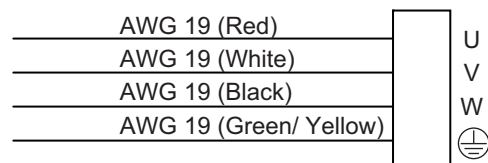

<Cable connection diagram>

Appendix 1.38 R-TM Terminator Connector

Application: Terminator for OPI interface

R-TM

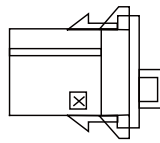

R-TM

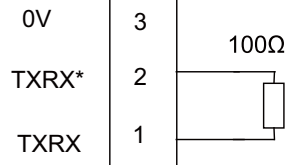

[R-TM]

Connector: 1-178288-3 (X type)

Contact: 1-175216-2 x2

Recommended manufacturer: Tyco Electronics

Resistor: 100Ω 1/4W

(Note 1) The parts used shall be Mitsubishi recommended parts. Equivalent parts may be used providing they are compatible with the specifications.

(Note 2) Cover the 100Ω terminator with a black insulation tube.

(Note 3) Stamp the connector name "R-TM" in white on the rear of the connector.

Appendix 1.39 SH21 Cable

Max. cable length: 30m

Application: Power supply communication cable

Power backup unit communication cable

Cable for Auxiliary axis/Servo drive units

SV1, SV2

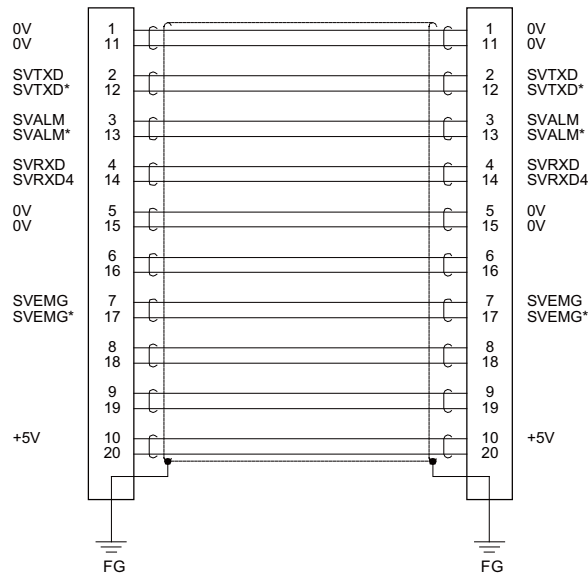
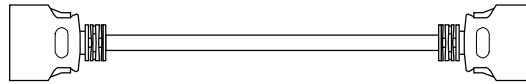

[SV1, SV2]

Plug: 10120-3000VE

Shell: 10320-52F0-008

Recommended manufacturer: 3M

Wire material: UL20276 AWG28x10P

Recommended manufacturer:

Toyokuni Electric Cable

Plug: 10120-3000VE

Shell: 10320-52F0-008

Recommended manufacturer: 3M

(Note) Fold the cable shield over the sheath, and wrap copper foil tape over it. Connect the wound copper foil tape to GND plate of the connector.

Appendix 1.40 SH41 Cable

Max. cable length: 1m (the maximum length of the cable when connected to the control unit via other units)

Application: Remote I/O cable
 between remote I/O,
 remote I/O-CNC control unit,
 remote I/O-Operation panel I/O unit,
 remote I/O-MITSUBISHI CNC machine operation panel A
 (between remote I/O units in a panel)

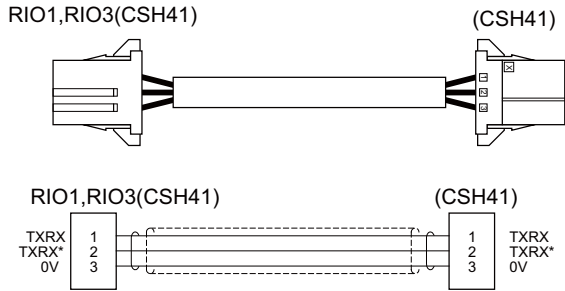

[RIO1, RIO2, RIO3]

Connector: 1-178288-3

Contact: 1-175218-2 x3

Recommended manufacturer:
 Tyco Electronics

Wire material:

MVVS 3C×0.5mm² (MIC 3C×0.5mm²)

Recommended manufacturer: Takeuchi Densen

Connector: 1-178288-3

Contact: 1-175218-2 x3













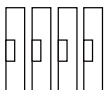
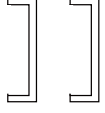

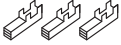

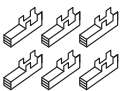
Recommended manufacturer:
 Tyco Electronics

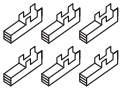
(Note 1) Protect both ends of the cable with insulated bushing.

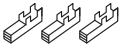
(Note 2) RIO1 and RIO3 can be used commonly.

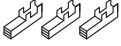
(Note 3) Use this cable for short applications, such as bridging the remote I/O units in the same panel. Normally use the FCUA-R211 cable with high noise withstand level.

Appendix 1.41 List of Cable Connector Sets

Type	Application	Package contents	
FCUA-CS000	Control unit - General I/O units	Connector (3M) 10120-3000VE x 2pcs. 	Shell kit (3M) 10320-52F0-008 x 2pcs. 
FCUA-CS301	Remote I/O unit - terminal block	Connector (3M) 7940-6500SC x 4pcs. 	Strain relief (3M) 3448-7940 x 2pcs. 
FCUA-CN200	200VAC power supply connector (for power supply unit PD25/PD27)	Connector (Tyco Electronics) 2-178288-3 x 1pc. 	Tin contact (Tyco Electronics) 1-175218-5 x 3 pcs. 
3-178127-6 1-175218-5 x 6 pcs.	24VDC power supply connector for power supply unit (PD25/PD27) (with power OFF detection)	Connector (Tyco Electronics) 3-178127-6 x 1pc. 	Tin contact (Tyco Electronics) 1-175218-5 x 6 pcs. 
1-178288-5 1-175218-5 x 6 pcs.	ON/OFF connector for power supply unit (PD25/PD27)	Connector (Tyco Electronics) 1-178288-5 x 1pc. 	Tin contact (Tyco Electronics) 1-175218-5 x 6 pcs. 
005057-9403 0016020103 x 3 pcs.	Emergency stop connector	Connector (MOLEX) 005057-9403 x 1pc. 	Gold contact (MOLEX) 0016020103 x 3 pcs. 
FCUA-CN211	Remote I/O communication connector	Connector (Tyco Electronics) 1-178288-3 x 1pc. 	Gold contact (Tyco Electronics) 1-175218-2 x 3pcs. 
FCUA-CN220	24VDC power supply connector	Connector (Tyco Electronics) 2-178288-3 x 1pc. 	Tin contact (Tyco Electronics) 1-175218-5 x 3pcs. 
FCUA-CN300	DIO connector	Connector (3M) 7940-6500SC x 2pcs. 	

Appendix 2

EMC Installation Guidelines

For details of the drive section (servo/spindle drive unit), refer to the "EMC Installation Guidelines" of instruction manuals for each drive unit.

Appendix 2.1 Introduction

EMC Directives became mandatory as of January 1, 1996. The subject products must have a CE mark attached indicating that the product complies with the Directives.

As the NC unit is a component designed to control machine tools, it is believed that it is not a direct EMC Directives subject. However, we would like to introduce the following measure plans to back up EMC Directives compliance of the machine tool as the NC unit is a major component of the machine tools.

- (1) **Methods of installation in control/operation panel**
- (2) **Methods of wiring cables to outside of panel**
- (3) **Introduction of members for measures**

Mitsubishi is carrying out tests to confirm the compliance to the EMC Directives under the environment described in this manual. However, the level of the noise will differ according to the equipment type and layout, control panel structure and wiring lead-in, etc.

Thus, we ask that the final noise level be confirmed by the machine manufacturer.

Appendix 2.2 EMC Directives

The EMC Directives largely regulate the following two items.

- Emission Capacity to prevent output of obstructive noise that adversely affects external devices.
- Immunity Capacity to not malfunction due to obstructive noise from external source.

The details of each level are classified in the table below.

It is assumed that the Standards and test details required for a machine tool are the same as these.

Class	Name	Details	EN Standards	
Emission				
	Radiated noise	Restriction of electromagnetic noise radiated through the air	EN61000-6-4 (General industrial machine)	EN55011 (CLASS: A)
	Conductive noise	Restriction of electromagnetic noise discharged from power supply line	EN61800-3 (Motor control unit)	
Immunity				
	Static electricity electrical discharge	(Example) Regulation of withstand level of static electricity electrical discharge accumulated in human body	EN61000-6-2 (General industrial machine) EN61800-3 (Motor control unit)	EN61000-4-2
	Radiation immunity	(Example) Simulation of immunity from digital wireless telephones		EN61000-4-3
	Burst immunity	(Example) Regulation of withstand level of noise from relay or plug and play		EN61000-4-4
	Conductive immunity	(Example) Regulation of withstand level of noise flowed from power supply wires, etc.		EN61000-4-6
	Power supply frequency magnetic field	(Example) Regulation of electromagnetic noise of 50/60Hz power supply frequency		EN61000-4-8
	Power supply dip (fluctuation)	(Example) Regulation of power voltage drop withstand level		EN61000-4-11
	Surge	(Example) Regulation of withstand level of noise caused by lightning		EN61000-4-5

Appendix 2.3 EMC Measures

The main items relating to EMC measures include the following.

- (1) Store the device in a sealed metal panel.
- (2) Ground all conductors that are floating electrically. Decrease the impedance.
- (3) Increase the distance between the drive line and signal wire.
- (4) Shield the cables wired outside of the panel.
- (5) Install a noise filter.

Take care to the following items to suppress the noise radiated outside of the panel.

- (1) Accurately ground the devices.
- (2) Use shielded cables.
- (3) Increase the electrical seal of the panel. Reduce the gaps and holes.

Appendix 2.4 Panel Structure

The design of the panel is a very important factor for the EMC measures, so take the following measures into consideration.

Appendix 2.4.1 Measures for Control Panel Body

- (1) Use metal for all members configuring the panel.
- (2) When joining the metal plate, treat the welded or contacting sections so that the impedance is reduced, and then fix with screws.

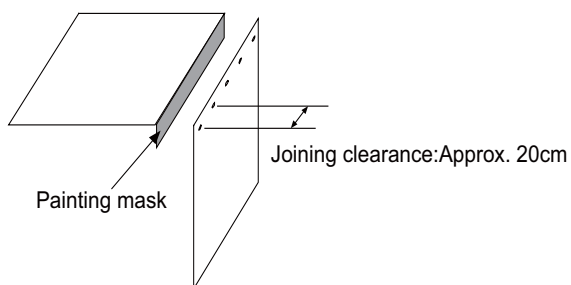

- (3) Note that if the plate warps due to the screw fixing, etc. By creating a clearance, noise could leak from that place.
- (4) Plate (nickel tin) the metal plate surface at the grounding plate, and connect the connections with a low impedance.
- (5) If there is a large opening, such as ventilation holes, make sure to close the hole.

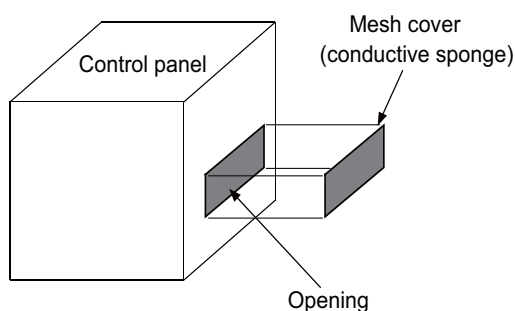

- (Note 1) Using screws to fix the plates that have been painted is the same as an insulated state. Peel the paint and fix the screws.

Appendix 2.4.2 Measures for Door

- (1) Use metal for all members configuring the panel.
- (2) When joining the door, use a gasket to lower the impedance of the contacting sections, or use a structure with a large contact area as shown below.
- (3) The EMI gasket or conductive packing must contact the metal surface uniformly and at the correct position.

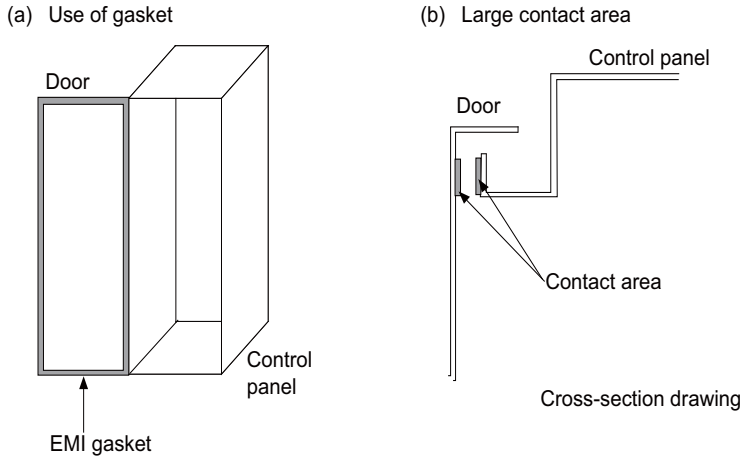

- (Note 1) When not using a gasket, ground the control panel grounding with a grounding wire to lower the door's impedance.
- (Note 2) Using screws to fix the plates that have been painted (attachment of packing) is the same as an insulated state. Peel the paint and fix the screws.

Appendix 2.4.3 Measures for Power Supply

- (1) Shield the power supply section and insert a filter to prevent the noise from flowing in or out. Selection of the noise filter capacity will differ according to the drive unit and devices being used. Refer to the "EMC Installation Guidelines" (BNP-B8582-45).

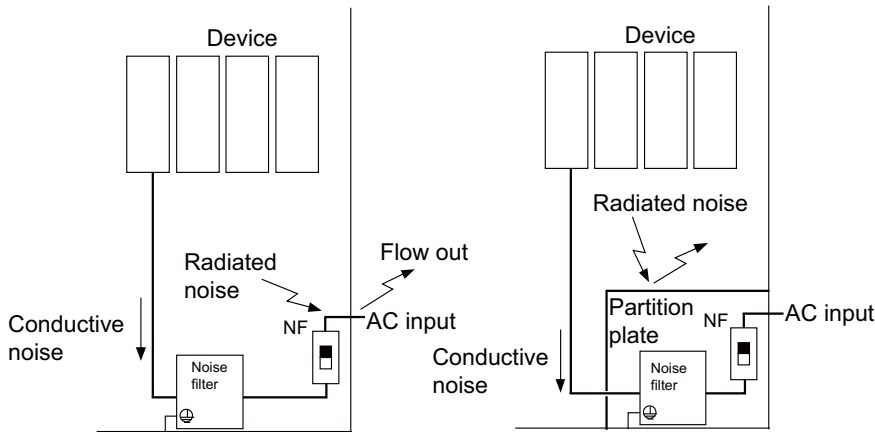

- (Note 1) The conductive noise can be suppressed by inserting a noise filter, but the radiated noise will flow out.
- (Note 2) The conductive and radiated noise can both be suppressed by adding a partition plate to the noise filter.

Appendix 2.5 Measures for Wiring in Panel

Cables act as antennas to propagate unnecessary noise, and thus must be appropriately shielded and treated.

The following measures must be sufficiently considered for the cables (SH21/G018/F012/FCUA-R211) that carry out high-speed communication.

Appendix 2.5.1 Precautions for Wiring in Panel

- (1) If the cables are led unnecessarily in the panel, they will pick up noise. Pay attention to the device layout and wire length so that the wiring length is as short as possible.

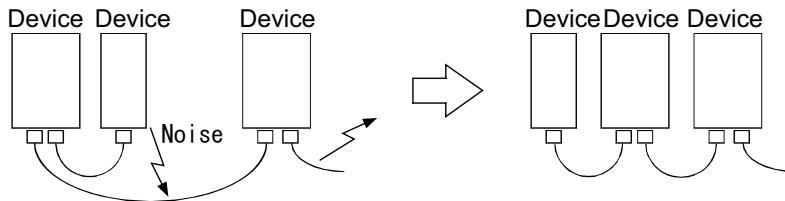

- (2) Always connect the grounding wire to the FG terminal indicated on the device.
- (3) Keep the distance between the drive line and detector cable to the drive section motor as far apart as possible when wiring.
- (4) Do not lead the power supply wire around the panel without using a filter.

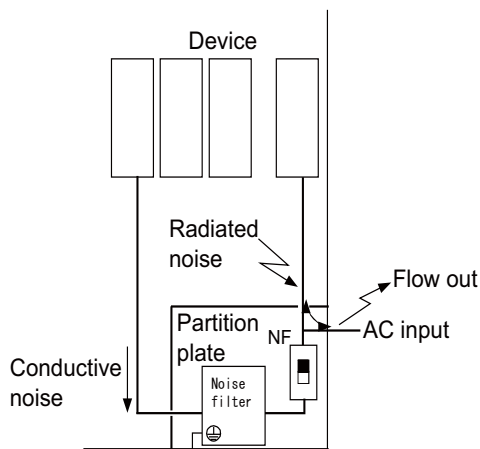

Appendix 2.5.2 Shield Treatment of Cables

Use shielded cables for the cables wired outside the panel.

Use a shield clamp within 10cm of the lead-out port from the panel. (Refer to "EMC Countermeasure Parts: Shield Clamp Fitting".)

(1) DC power supply cable [F110/F070 cable]

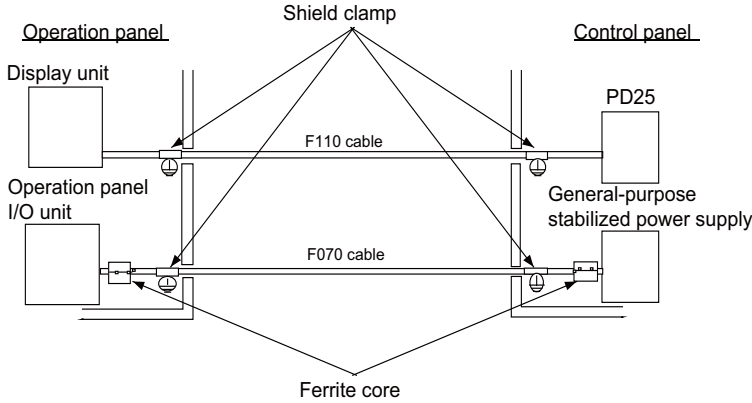

- Use a shield clamp within 10cm from the panel's inlet/outlet.
- When using a ferrite core, install it on both ends of the connected units.
- Always install a ferrite core (Refer to "EMC Countermeasure Parts: Ferrite Core".) on the general-purpose stabilized power supply. The ferrite core may not be required depending on the selected power supply.

(2) Remote I/O cable [FCUA-R211 cable]

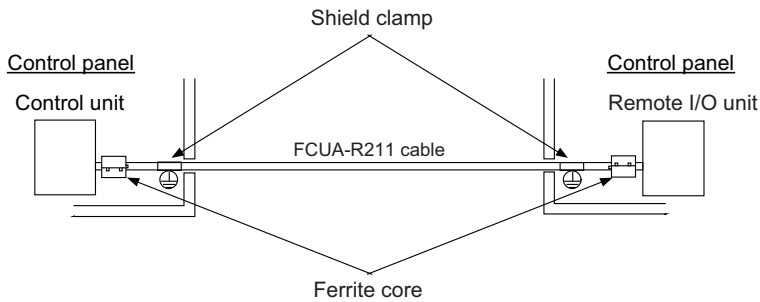

- Use a shield clamp within 10cm from the panel's inlet/outlet.
- When using a ferrite core, install it on both ends of the connected units.

(3) Servo communication cable [SH21 cable]

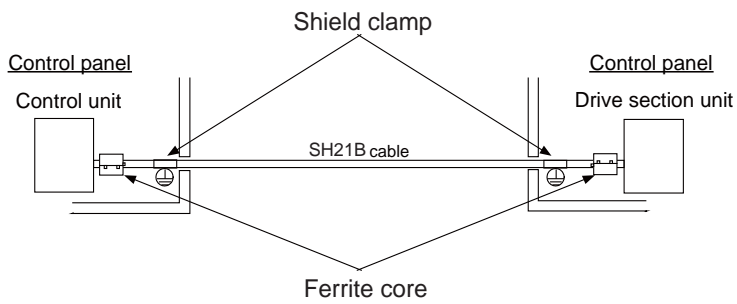

- Use a shield clamp within 10cm from the panel's inlet/outlet.
- When using a ferrite core, install it on both ends of the connected units.

(4) Ethernet cable

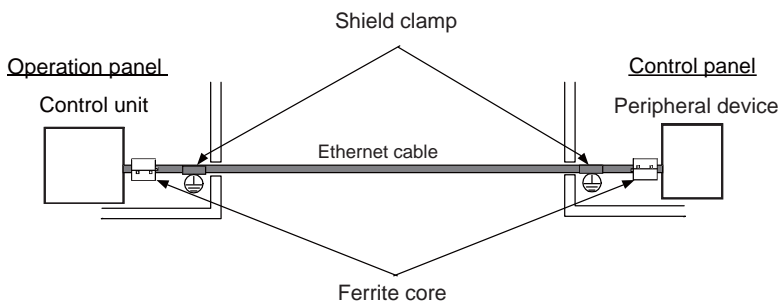

- Use a shielded cable. Use a shield clamp within 10cm from the panel's inlet/outlet.
- When using a ferrite core, install it on both ends of the connected units.

Appendix 2.6 EMC Countermeasure Parts

Appendix 2.6.1 Shield Clamp Fitting

The effect can be improved by directly connecting the cable's shield sheath to the grounding plate as shown below. Install the grounding plate near the outlet (within 10cm) of each panel, and press against the grounding plate with the clamp fitting.

If the cables are thin, several can be bundled and clamped together.

To provide sufficient frame ground, install the grounding plate directly on the cabinet or connect with a grounding wire.

	A	B	C	Enclosed fittings
Ground Plate #D	100	86	30	Clamp fitting A×2
Ground Plate #E	70	56	-	Clamp fitting B×1

	L1 (maximum dimension when it is open)	L2 (reference dimension)
Clamp fitting A	25	(77)
Clamp fitting B	12	(54)

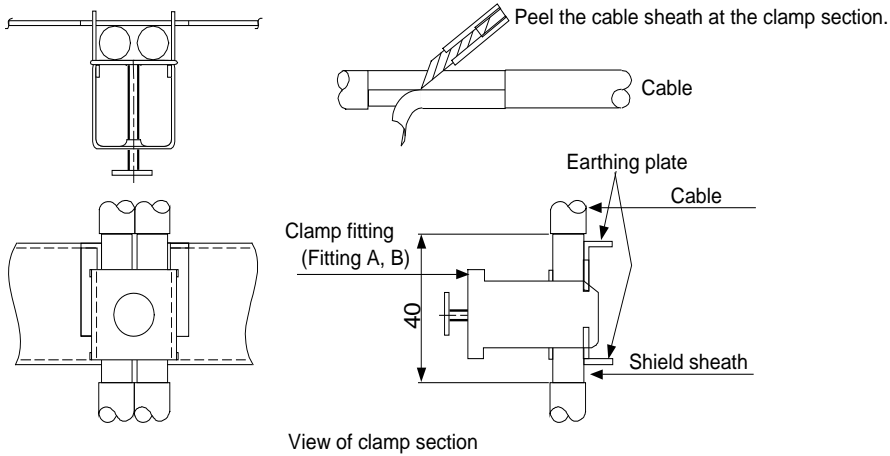

• Outline drawing

Earthing plate

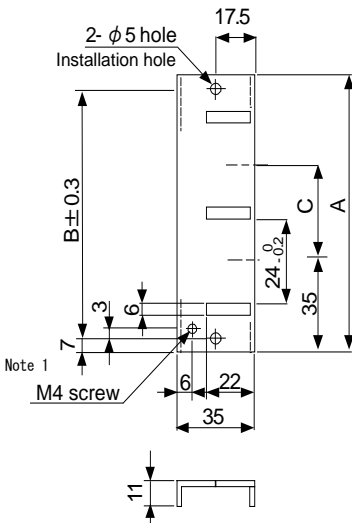

Clamp fitting

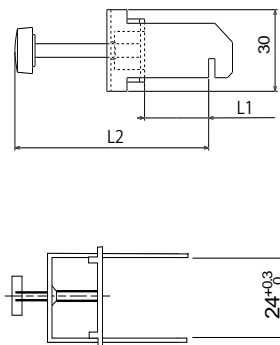

[Unit: mm]

(Note 1) Screw hole for wiring to earthing plate in cabinet.
 (Note 2) The earthing plate thickness is 1.6mm.

Appendix 2.6.2 Ferrite Core

The ferrite core is mounted integrally with the plastic case.

This can be installed with one touch without cutting the interface cable or power supply cable.

This ferrite core is effective against common mode noise, allowing measures against noise without affecting the quality of the signal.

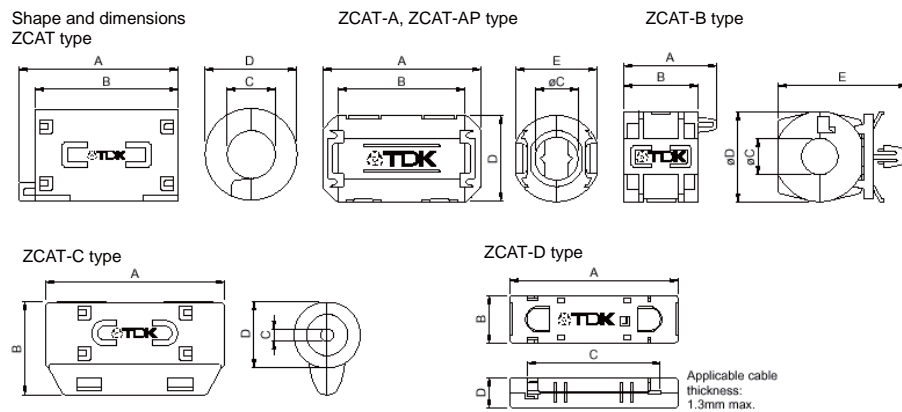

Recommended ferrite core: TDK ZCAT Series

							Unit: mm	
Part Name	A	B	φC	φD	E	Applicable cable outer diameter	Mass (g)	
ZCAT1518-0730-M(-BK)*1	22±1	18±1	7±1	15±1	-	7max.	6	
ZCAT1518-0730(BK)*2	22±1	18±1	7±1	15±1	-	7max.	6	
ZCAT2017-0930-M(-BK)	21±1	17±1	9±1	20±1	-	9max.	11	
ZCAT2032-0930-M(-BK)*1	36±1	32±1	9±1	19.5±1	-	9max.	22	
ZCAT2032-0930(-BK)*2	36±1	32±1	9±1	19.5±1	-	9max.	22	
ZCAT2132-1130-M(-BK)*1	36±1	32±1	11±1	20.5±1	-	11max.	22	
ZCAT2132-1130(-BK)*2	36±1	32±1	11±1	20.5±1	-	11max.	22	
ZCAT3035-1330-M(-BK)*1	39±1	34±1	13±1	30±1	-	13max.	63	
ZCAT3035-1330(-BK)*2	39±1	34±1	13±1	30±1	-	13max.	63	
ZCAT1525-0430AP-M(-BK)	25±1	20±1	4±1	15±1	11.5±1	2.5 to 4(USB)	7	
ZCAT1325-0530A-M(-BK)*1	25±1	20±1	5±1	12.8±1	11.2±1	3 to 5(USB)	7	
ZCAT1325-0530A(-BK)	25±1	20±1	5±1	12.8±1	11.2±1	3 to 5(USB)	7	
ZCAT1730-0730A-M(-BK)	30±1	23±1	7±1	16.5±1	15±1	4 to 7(USB)	12	
ZCAT2035-0930A-M(-BK)*1	35±1	28±1	9±1	19.5±1	17.4±1	6 to 9	22	
ZCAT2035-0930A(-BK)	35±1	28±1	9±1	19.5±1	17.4±1	6 to 9	22	
ZCAT2235-1030A-M(-BK)	35±1	28±1	10±1	21.5±1	20±1	8 to 10	27	
ZCAT2436-1330A-M(-BK)	36±1	29±1	13±1	23.5±1	22±1	10 to 13	29	
ZCAT2017-0930B-M(-BK)	21±1	17±1	9±1	20±1	28.5±1	9max.	12	
ZCAT2749-0430C-M(-BK)	49±1	27±1	4.5±1	19.5±1	-	4.5max.	26	
ZCAT4625-3430D(-BK)	45.5±1	24.5±1	34±1	12±1	-	26 For core flat cable	32	
ZCAT4625-3430DT(-BK)*3	45.5±1	24.5±1	34±1	13±1	-	26 For core flat cable	32	
ZCAT6819-5230D(-BK)	67.5±1	18.5±1	52±1	16±1	-	40 For core flat cable	58	
ZCAT6819-5230DT(-BK)*3	67.5±1	18.5±1	52±1	17±1	-	40 For core flat cable	58	

*1 The M stamp is attached.

*2 A fixing band is attached at shipment.

*3 The core is fixed with double-sided tape. (The tape is enclosed with the part.)

● ZCAT-B type: Cabinet fixing type installation hole φ4.8 to 4.9mm, plate thickness 0.5 to 2mm

● ZCAT-AP, ZCAT-C type: Structure that prevents easy opening after case is closed.

Appendix 2.6.3 Surge Absorber

Make sure that the surge does not directly enter the AC line of the general-purpose stabilized power supply (user-prepared) supplying power to the control unit and DIO. Select the following product or equivalent for the surge absorber. Refer to the manufacturer catalog for detailed characteristics, outline and connection methods of the surge absorber.

(1) Part name: RAV-781BYZ-2

Manufacturer: OKAYA ELECTRIC INDUSTRIES

Circuit voltage 50/60Hz Vrms	Max. tolerable circuit voltage	Clamp voltage V±10%	Surge withstand level 8/20µs	Surge electrical discharge start voltage 1.2/50µs	Static capacity	Working temperature range
250V 3φ	300V	783V	2,500A	20kV	75pF	-20 to +70°C

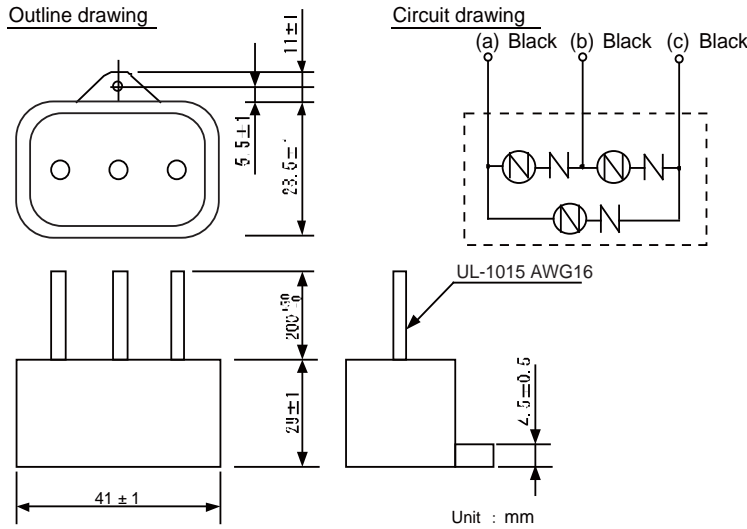

(2) Part name: RAV-781BXZ-4

Manufacturer: OKAYA ELECTRIC INDUSTRIES

Circuit voltage 50/60Hz Vrms	Max. tolerable circuit voltage	Clamp voltage V±10%	Surge withstand level 8/20µs	Surge electrical discharge start voltage 1.2/50µs	Static capacity	Working temperature range
250V 3φ	300V	700V	2,500A	2kV	75pF	-20 to +70°C

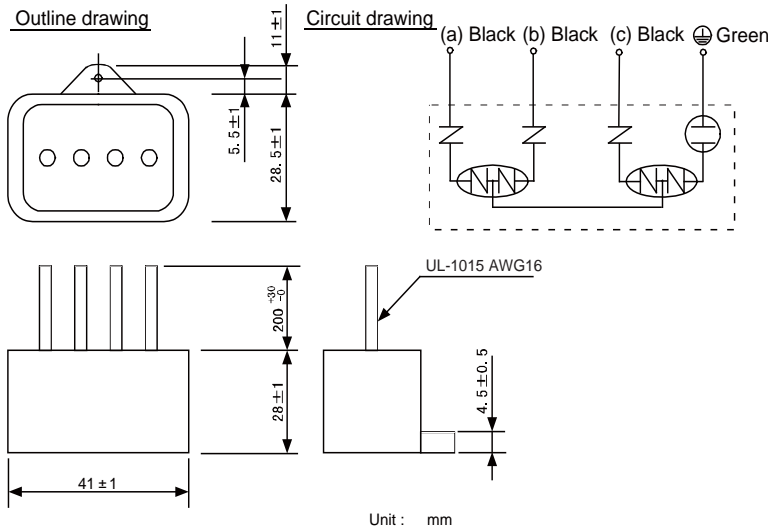

(3) Example of surge absorber installation

An example of installing the surge absorber in the machine control panel is shown below.

A short-circuit fault will occur in the surge absorber if a surge exceeding the tolerance is applied. Thus, install a circuit protection breaker in the stage before the surge absorber. Note that almost no current flows to the surge absorber during normal use, so a breaker installed as the circuit protection for another device can be used for the surge absorber.

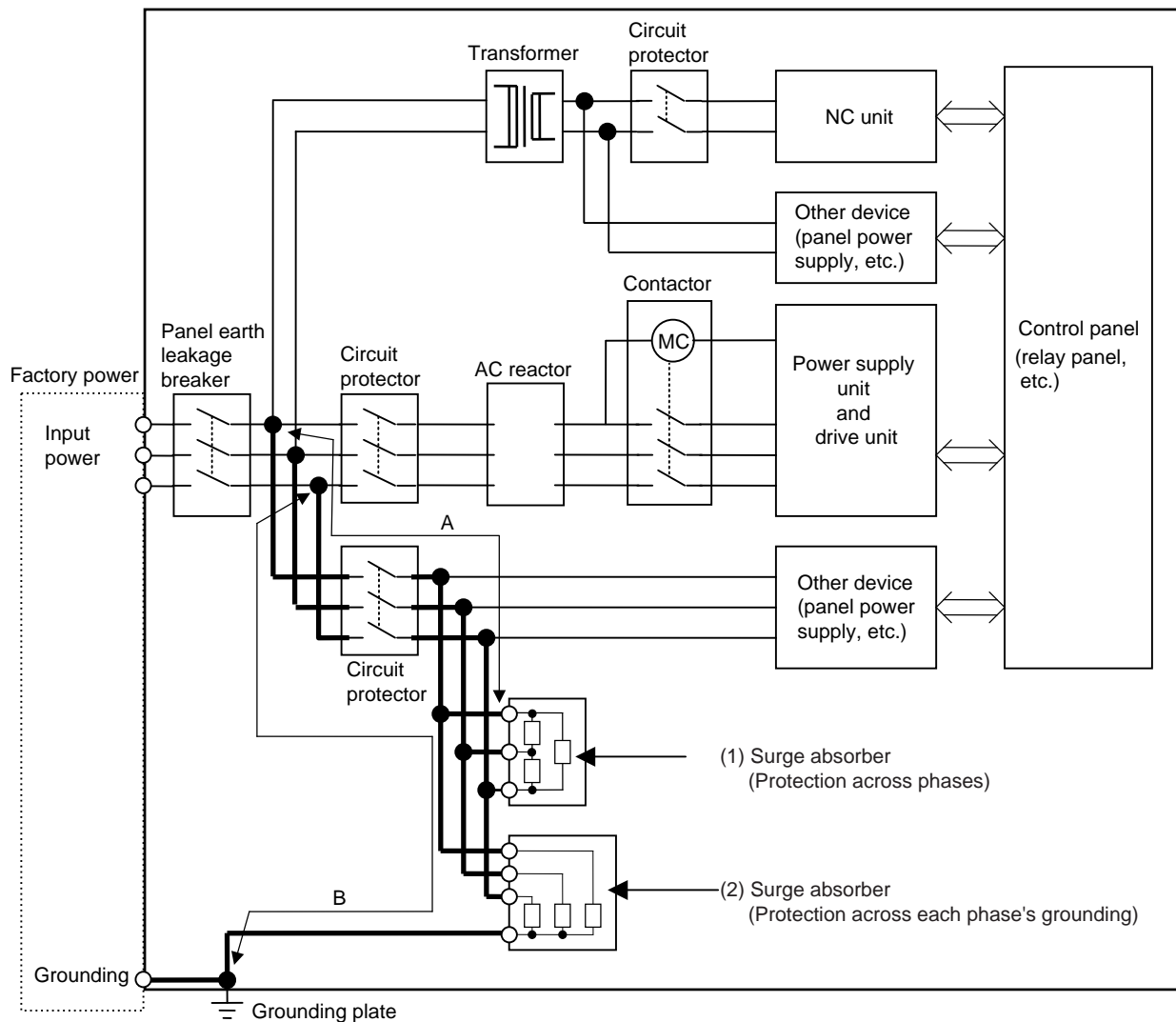

Surge absorber installation

⚠ CAUTION

1. The wires from the surge absorber should be connected without extensions.
2. If the surge absorber cannot be installed just with the enclosed wires, keep the wiring length of A and B to 2m or less. If the wires are long, the surge absorber's performance may drop and inhibit protection of the devices in the panel.
3. Surge absorber to be selected varies depending on input power voltage.

Appendix 2.6.4 Selection of Stabilized Power Supply

Consider the following characteristics when selecting the stabilized power supply (prepared by machine manufacturer). Use a power supply that complies with CE Marking or that follows the safety standards given below.

Stabilized power supply selection items

Item		Standard setting	Remarks
Output	Voltage fluctuation	±5%	±5% or less of 24VDC output
	Ripple noise	120mV (max.)	
	Spike noise	500mV (max.)	
Output current		---	Refer to the maximum current consumption of the unit in use and calculate.
Output holding time		20ms (min)	Instantaneous power failure time (AC side)

Standards

Safety Standards: UL1950, CSA C22.2 No. 234 approved, IEC950 compliant

Noise Terminal Voltage: FCC Class A, VCCI-Class A

High Harmonics Current Restrictions: IEC61000-3-2

Appendix 3

Restrictions for Lithium Batteries

Appendix 3.1 Restriction for Packing

The United Nations Dangerous Goods Regulations "Article 12" became effective from 2003. When transporting lithium batteries with means subject to the UN Regulations, such as by air transport, measures corresponding to the Regulations must be taken.

The UN Regulations classify the batteries as dangerous goods (Class 9) or not dangerous goods according to the lithium metal content. To ensure safety during transportation, lithium batteries (battery unit) directly exported from Mitsubishi are packaged in a dedicated container (UN package) for which safety has been confirmed.

When the customer is transporting these products with means subject to the UN Regulations, such as air transport, the shipper must follow the details explained in this section "Handling by User".

The followings are restrictions for transportation. Each restriction is specified based on the recommendation of the United Nations.

Area	Transportation method	Restriction	Special clause
World	Air	ICAO, IATA	-
World	Marine	IMO	188
United States	All (air, marine, land)	DOT	49 CFR 173.185
Europe	land	RID, ADR	188

Appendix 3.1.1 Target Products

The following Mitsubishi NC products use lithium batteries. If the lithium metal content exceeds 1g for battery cell and 2g for battery, the battery is classified as dangerous good (Class9).

In order to avoid an accidental actuation during the transportation, all lithium battery products incorporated in a machinery or device must be fixed securely and must be shipped with wrapped over the outer package as to prevent damage or short-circuits.

(1) Materials falling under Class 9

Mitsubishi type (Type for arrangement)	Battery type	Lithium metal content	Number of incorporated ER6V batteries	Application (Data backup)	Battery class	Outline dimension drawing
CR23500SE-CJ5	CR23500SE-CJ5	1.52g	-	For NC SRAM (M500)	Battery cell	Refer to "Battery Option" in the specification manual for drive unit you are using for the outline dimension drawing for servo.

(2) Materials not falling under Class 9

Mitsubishi type (Type for arrangement)	Battery type	Lithium metal content	Number of incorporated ER6V batteries	Application (Data backup)	Battery class	Outline dimension drawing
CR2032 (for built-in battery)	CR2032	0.067g	-	For NC SRAM/	Battery cell	Refer to "Battery Option" in the specification manual for drive unit you are using for the outline dimension drawing for servo.
CR2450 (for built-in battery)	CR2450	0.173g	-	For NC SRAM		
ER6, ER6V series (for built-in battery)	ER6, ER6V	0.65g	-	For NC SRAM/ servo detector		
A6BAT(MR-BAT)	ER17330V	0.48g	-	For servo detector		
Q6BAT	Q6BAT	0.49g	-	For NC SRAM		

(Note) If the number of batteries exceeds 24 batteries for the battery cell or 12 batteries for the battery, the dedicated packing (for materials falling under Class 9) is required.

(Example) Rating nameplate for battery units

MITSUBISHI BATTERY UNIT	
TYPE	MDS-A-BT-6 ← Mitsubishi type
OUTPUT DC	3.6 V
LITHIUM BATTERIES: ER6 x6	Class 9 ← Safety class
(Battery Type: ER6-B6-11)	← Battery manufacturer type
Mercury Content:	Less than 1 ppm
Lithium Metal Content:	3.9 g ← Lithium metal content
MITSUBISHI ELECTRIC CORPORATION JAPAN 	

Appendix 3.1.2 Handling by User

The following technical opinion is solely Mitsubishi's opinion. The shipper must confirm the latest IATA Dangerous Goods Regulations, IMDG Codes and laws and orders of the corresponding export country.

These should be checked by the company commissioned for the actual transportation.

IATA: International Air Transport Association

IMDG Code: A uniform international code for the transport of dangerous goods by seas determined by IMO (International Maritime Organization).

■ **When shipping isolated lithium battery products**

(1) Reshipping in Mitsubishi UN packaging (Class 9)

Mitsubishi packing applies package specifications complying with the UN Packing Instruction. The user only needs to add the following details before shipping. (Consult with the shipping company for details.)

(a) Indication of container usage mark on exterior box (Label with following details recorded.)

- [1] Proper shipping name (Lithium batteries)
- [2] UN NO. (UN3090 for isolated battery, UN3091 for battery incorporated in a device or included)
- [3] Shipper and consignee's address and name

Example of completing form

SHIPPER: Shipper information	CONSIGNEE: Consignee information
PROPER SHIPPING NAME LITHIUM BATTERIES	
UN NO. : UN3090 CLASS: 9 SUBSIDIARY RISK	
PACKING GROUP: II PACKING INST.: 903	

- [4] A care label with a telephone number for additional information (120x110mm)
 (A care label is to be attached on the outer package. Shipping less than or equal to 4 isolated batteries incorporated in machinery does not need care label.)

Lithium battery care label (Air transportation sample)



- (b) Preparation of shipping documents and declaration of dangerous goods
 For information required in description, refer to "Product information data sheet".

(2) When packaged by user

The user must follow UN Regulations when packing, preparing for shipping and preparing the indications, etc.

(a) Packing a lithium battery falling under Class 9

[1] Consult with The Ship Equipment Inspection Society of Japan for details on packaging.

[2] Prepare for shipping as explained in "(1) Reshipping in Mitsubishi UN packaging".

The Ship Equipment Inspection Society of Japan <http://www.hakuyohin.or.jp/english.html>

(b) Packing a lithium battery not falling under Class 9

[1] Cells and batteries are separated so as to prevent short circuits and are stored in a strong outer packaging (12 batteries or less, 24 battery cells or less).

[2] Prepare for the certificates or test results showing compliance to drop test from 1.2m in height.

(The safety test results have been obtained from the battery manufacturer. Consult with Mitsubishi when the safety test results are required.)

[3] Prepare for shipping as explained in "(1) Reshipping in Mitsubishi UN packaging (Class 9)".

■ **When shipping lithium batteries incorporating in a device or machinery**

Dedicated packaging (UN packaging) is not required for batteries incorporated in device or machinery. Yet, make sure to fix the contents securely before the transportation as to prevent damage and short-circuit.

If machinery and devices which incorporates lithium battery is not waterproof, package must be waterproof material.

Check with your shipping company for details on packing and transportation.

Appendix 3.1.3 Reference

Refer to the following materials for details on the regulations and responses.

Guidelines regarding transportation of lithium batteries and lithium ion batteries (Edition 2)..... Battery Association of Japan

Appendix 3.2 Products information data sheet (ER battery)

MSDS system does not cover the product used in enclosed state. The ER battery described in this section applies to that product.

This description is applied to the normal use, and is provided as reference but not as guarantee.

This description is based on the lithium battery's (ER battery) hazardous goods data sheet (Products information data sheet) which MITSUBISHI has researched, and will be applied only to the ER batteries described in the previous section "Restriction for Packing".

(1) Outline of hazard

Principal hazard and effect	Not found.
Specific hazard	As the chemical substance is stored in a sealed metal container, the battery itself is not hazardous. But when the internal lithium metal attaches to human skin, it causes a chemical skin burn. As a reaction of lithium with water, it may ignite or forms flammable hydrogen gas.
Environmental effect	Not found.
Possible state of emergency	Damages or short-circuits may occur due to external mechanical or electrical pressures.

(2) First-aid measure

Inhalation	If a person inhales the vapor of the substance due to the battery damage, move the person immediately to fresh air. If the person feels sick, consult a doctor immediately.
Skin contact	If the content of the battery attaches to human skin, wash off immediately with water and soap. If skin irritation persists, consult a doctor.
Eye contact	In case of contact with eyes due to the battery damage, rinse immediately with a plenty of water for at least 15 minutes and then consult a doctor.
Ingestion	If swallowed, consult a doctor immediately.

(3) Fire-fighting measure

Appropriate fire-extinguisher	Dry sand, dry chemical, graphite powder or carbon dioxide gas
Special fire-fighting measure	Keep the battery away from the fireplace to prevent fire spreading.
Protectors against fire	Fire-protection gloves, eye/face protector (face mask), body/skin protective cloth

(4) Measure for leakage

Environmental precaution	Dispose of them immediately because strong odors are produced when left for a long time.
How to remove	Get them absorbed into dry sand and then collect the sand in an empty container.

(5) Handling and storage

Handling	Cautions for safety handling	Do not peel the external tube or damage it. Do not dispose of the battery in fire or expose it to heat. Do not immerse the battery in water or get it wet. Do not throw the battery. Do not disassemble, modify or transform the battery. Do not short-circuit the battery.
	Storage condition	Avoid direct sunlight, high temperature and high humidity. (Recommended temp. range: +5 to +35C°, humidity: 70%RH or less)
Storage	Material to avoid	Flammable or conductive material (Metal: may cause a short-circuit)

(6) Physical/chemical properties

Appearance	Physical form	Solid
	Shape	Cylinder type
	Smell	Odorless
	pH	Not applicable (insoluble)
	Boiling point/Boiling range, Melting point, Decomposition temperature, Flash point	No information

(7) Stability and reactivity

Stability	Stable under normal handling condition.
Condition to avoid	Do not mix multiple batteries with their terminals uninsulated. This may cause a short-circuit, resulting in heating, bursting or ignition.
Hazardous decomposition products	Irritative or toxic gas is emitted in the case of fire.

(8) Toxicological information

As the chemical substance is stored in a sealed metal container, the battery has no harmfulness. Just for reference, the table below describes the main substance of the battery.

< Lithium metal >

Acute toxicity	No information
Local effect	Corrosive action in case of skin contact

< Thionyl chloride >

Acute toxicity	LC ₅₀ : 500ppm (inhaled administration to rat)
Local effect	The lungs can be damaged by chronic cough, dyspnea and asthma.

< Aluminum chloride >

Acute toxicity	LD ₅₀ : 3700ppm (oral administration to rat)
Local effect	Not found.

< Lithium chloride >

Acute toxicity	LD ₅₀ : 526ppm (oral administration to rat)
Local effect	The central nerves and kidney can be influenced.

< Carbon black >

Acute toxicity	LD ₅₀ : 2,000mg/kg > (rat)
Carcinogenicity	LARC group 2 (suspected of being carcinogenic)

(9) Ecological information

Mobility, Persistence/ Decomposability, Bio- accumulation potential, Ecological toxicity	Not found.
---	------------

(10) Caution for disposal

Dispose of the battery following local laws or regulations.

Pack the battery properly to prevent a short-circuit and avoid contact with water.

Appendix 3.3 Issuing Domestic Law of the United States for Primary Lithium Battery Transportation

Federal Aviation Administration (FAA) and Research and Special Programs Administration (RSPA) announced an additional regulation (interim final rule) for the primary lithium batteries transportation restrictions item in "Federal Register" on Dec.15 2004.

This regulation became effective from Dec.29, 2004. This law is a domestic law of the United States, however it also applies to the domestic flight and international flight departing from or arriving in the United States. Therefore, when transporting lithium batteries to the United State, or within the United State, the shipper must take measures required to transport lithium batteries. Refer to the Federal Register and the code of Federal Regulation ("Reference" from the previous section "Restriction for Packing") for details.

Appendix 3.3.1 Outline of Regulation

- (1) Transporting primary lithium battery by passenger aircraft is forbidden.
 - (a) Excluding primary lithium battery for personal use in a carry-on or checked luggage (Lithium metal content should be not more than 5g for cell and 25g for battery. For details on the lithium metal content, refer to "Transportation Restrictions for Lithium Batteries: Target Products".)
- (2) When transporting primary lithium battery by cargo aircraft, indicate that transportation by passenger aircraft is forbidden on the exterior box.

Appendix 3.3.2 Target Products

All NC products for which the lithium batteries are used are subject to the regulation. (Refer to the table of "Target Products" from the previous section "Restriction for Packing".)

Appendix 3.3.3 Handling by User

The "Target Products" from the previous section "Outline of Regulation" described above is solely Mitsubishi's opinion. The shipper must confirm orders of "Transportation Restrictions for Lithium Batteries: Reference" described below for transportation method corresponding the regulation.

These should be checked by the company commissioned for the actual lithium battery transportation.

(1) Indication of exterior box

When transporting primary lithium battery by cargo aircraft, indicate that transportation by passenger aircraft is forbidden on the exterior box.

Display example

<p>PRIMARY LITHIUM BATTERIES FORBIDDEN FOR TRANSPORT ABOARD PASSENGER AIRCRAFT.</p>
--

- (a) The character color must be displayed with contrast. (black characters against white background, black characters against yellow background, etc.)
- (b) The height (size) of characters to be displayed is prescribed depending on the packaging mass. (When the total mass is over 30kg: at least 12mm, When the total mass is less than 30kg: at least 6mm)

Appendix 3.3.4 Reference

- (1) 49CFR (Code of Federal Regulation, Title49) (173.185 Lithium batteries and cells.)
 Search from the following URL.
<http://www.gpoaccess.gov/cfr/index.html>
- (2) DOT regulation body (Department of Transportation)
 Search "69fr-75207.pdf" from the following URL.
<http://phmsa.dot.gov/hazmat>

Appendix 3.4 Restriction related to EU Battery Directive

EU Battery Directive (2006/66/EC) has been enforced since September 26th in 2008. Hereby, battery and machinery incorporating battery marketed in European Union countries must be in compliance with the EU Battery Directive. Lithium battery provided by MITSUBISHI are subjected to this restriction.

Appendix 3.4.1 Important Notes

Follow the instruction bellow as shipping products incorporating MITSUBISHI device.

- (1) When shipping products incorporating MITSUBISHI device any time later than September 26th, 2008, the symbol mark shown as Figure 1 in section "Information for end-user" is required to be attached on the machinery or on the package. Also, the explanation of the symbol must be added.
- (2) Machinery with battery and maintenance battery produced before the EU Battery Directive are also subjected to the restriction. When shipping those products to EU countries later than September 26th, 2008, follow the instruction explained in (1).

Appendix 3.4.2 Information for end-user



Figure 1

Note: This symbol mark is for EU countries only.

This symbol mark is according to the directive 2006/66/EC Article 20 Information for end-users and Annex II.

Your MITSUBISHI ELECTRIC product is designed and manufactured with high quality materials and components which can be recycled and/or reused. This symbol means that batteries and accumulators, at their end-of-life, should be disposed of separately from your household waste.

If a chemical symbol is printed beneath the symbol shown above, this chemical symbol means that the battery or accumulator contains a heavy metal at a certain concentration. This will be indicated as follows: Hg: mercury (0,0005%), Cd: cadmium (0,002%), Pb: lead (0,004%)

In the European Union there are separate collection systems for used batteries and accumulators. Please, dispose of batteries and accumulators correctly at your local community waste collection/recycling centre.

Please, help us to conserve the environment we live in!

Appendix 4

Precautions for Compliance to UL/c-UL Standards

Observe the following matters to comply with UL/c-UL Standards.

Refer to "Instruction Manual for Compliance with UL/c-UL Standard"(BNP-B2429-003) for details.

- (1) Selection of external 24VDC power supply unit (The unit shall be prepared by the machine tool builder.)

This NC system complies with the UL Standards on the condition that the stabilized power supply unit supplying 24VDC to each unit is a UL-approved part.

Use a UL-approved part for the stabilized power supply unit supplying 24VDC to each unit.

- (2) Unit ambient temperature

This NC system complies with the UL Standards on the condition that the unit is used at a temperature less than the maximum ambient temperature given in "Environment Conditions" section. Make sure that the maximum ambient temperature of each unit does not exceed the temperature given in "Environment Conditions" section.

Revision History

Date of revision	Manual No.	Revision details
Dec. 2012	IB(NA)1501151-A	First edition created.
Dec. 2013	IB(NA)1501151-B	The construction of chapters and sections were revised. - "5 EMC Installation Guidelines" to Appendix 2. - "6 Restrictions for Lithium Batteries" to Appendix 3. - "7 Precautions for Compliance to UL/c-UL Standards" to Appendix 4. - "8 Cable" to Appendix 1. Mistakes were corrected.
Feb. 2014	IB(NA)1501151-C	Following chapters were revised. - "4.2.3 Connecting with Emergency Stop Signal" - "Appendix 1.32 G380 Cable" - "Appendix 1.33 G395 Cable" - "Appendix 1.34 G396 Cable" The title of the chapter was revised. - "4.2.5 Connecting with Drive Unit" Mistakes were corrected.

Global Service Network

AMERICA

MITSUBISHI ELECTRIC AUTOMATION INC. (AMERICA FA CENTER)

Central Region Service Center
500 CORPORATE WOODS PARKWAY, VERNON HILLS, ILLINOIS 60061, U.S.A.
TEL: +1-847-478-2500 / FAX: +1-847-478-2650

Michigan Service Satellite
ALLEGAN, MICHIGAN 49010, U.S.A.
TEL: +1-847-478-2500 / FAX: +1-847-478-2650

Ohio Service Satellite
LIMA, OHIO 45901, U.S.A.
TEL: +1-847-478-2500 / FAX: +1-847-478-2650
CINCINNATI, OHIO 45201, U.S.A.
TEL: +1-847-478-2500 / FAX: +1-847-478-2650

Minnesota Service Satellite
ROGERS, MINNESOTA 55374, U.S.A.
TEL: +1-847-478-2500 / FAX: +1-847-478-2650

West Region Service Center
16900 VALLEY VIEW AVE., LAMIRADA, CALIFORNIA 90638, U.S.A.
TEL: +1-714-699-2625 / FAX: +1-847-478-2650

Northern CA Satellite
SARATOGA, CALIFORNIA 95070, U.S.A.
TEL: +1-714-699-2625 / FAX: +1-847-478-2650

Pennsylvania Service Satellite
PITTSBURG, PENNSYLVANIA 15644, U.S.A.
TEL: +1-732-560-4500 / FAX: +1-732-560-4531

Connecticut Service Satellite
TORRINGTON, CONNECTICUT 06790, U.S.A.
TEL: +1-732-560-4500 / FAX: +1-732-560-4531

South Region Service Center
1845 SATTELITE BOULEVARD STE. 450, DULUTH, GEORGIA 30097, U.S.A.
TEL: +1-678-258-4529 / FAX: +1-678-258-4519

Texas Service Satellites
GRAPEVINE, TEXAS 76051, U.S.A.
TEL: +1-678-258-4529 / FAX: +1-678-258-4519
HOUSTON, TEXAS 77001, U.S.A.
TEL: +1-678-258-4529 / FAX: +1-678-258-4519

Tennessee Service Satellite
Nashville, Tennessee, 37201, U.S.A.
TEL: +1-678-258-4529 / FAX: +1-678-258-4519

Florida Service Satellite
WEST MELBOURNE, FLORIDA 32904, U.S.A.
TEL: +1-678-258-4529 / FAX: +1-678-258-4519

Canada Region Service Center
4299 14TH AVENUE MARKHAM, ONTARIO L3R 0J2, CANADA
TEL: +1-905-475-7728 / FAX: +1-905-475-7935

Canada Service Satellite
EDMONTON, ALBERTA T5A 0A1, CANADA
TEL: +1-905-475-7728 FAX: +1-905-475-7935

Mexico Region Service Center
MARIANO ESCOBEDO 69 TLALNEPANTLA, 54030 EDO. DE MEXICO
TEL: +52-55-3067-7500 / FAX: +52-55-9171-7649

Monterrey Service Satellite
MONTERREY, N.L., 64720, MEXICO
TEL: +52-81-8365-4171

BRAZIL

MELCO CNC do Brasil Comércio e Serviços S.A

Brazil Region Service Center
ACESSO JOSE SARTORELLI, KM 2.1 CEP 18550-000, BOITUVA-SP, BRAZIL
TEL: +55-15-3363-9900 / FAX: +55-15-3363-9911

EUROPE

MITSUBISHI ELECTRIC EUROPE B.V.
GOTHAER STRASSE 10, 40880 RATINGEN, GERMANY
TEL: +49-2102-486-0 / FAX: +49-2102-486-5910

Germany Service Center
KURZE STRASSE, 40, 70794 FILDERSTADT-BONLANDEN, GERMANY
TEL: +49-711-770598-123 / FAX: +49-711-770598-141

France Service Center DEPARTEMENT CONTROLE NUMERIQUE
25, BOULEVARD DES BOUVETS, 92741 NANTERRE CEDEX FRANCE
TEL: +33-1-41-02-83-13 / FAX: +33-1-49-01-07-25

France (Lyon) Service Satellite DEPARTEMENT CONTROLE NUMERIQUE
120, ALLEE JACQUES MONOD 69800 SAINT PRIEST FRANCE
TEL: +33-1-41-02-83-13 / FAX: +33-1-49-01-07-25

Italy Service Center
VIALE COLLEONI, 7 - CENTRO DIREZIONALE COLLEONI PALAZZO SIRIO INGRESSO 1
20864 AGRATE BRIANZA (MB), ITALY
TEL: +39-039-6053-342 / FAX: +39-039-6053-206

Italy (Padova) Service Satellite
VIA G. SAVELLI, 24 - 35129 PADOVA, ITALY
TEL: +39-039-6053-342 / FAX: +39-039-6053-206

U.K. Branch
TRAVELLERS LANE, HATFIELD, HERTFORDSHIRE, AL10 8XB, U.K.
TEL: +49-2102-486-0 / FAX: +49-2102-486-5910

Spain Service Center
CTRA. DE RUBI, 76-80-APDO. 420
08173 SAINT CUGAT DEL VALLES, BARCELONA SPAIN
TEL: +34-935-65-2236 / FAX: +34-935-65-1579

Poland Service Center
UL. KRAKOWSKA 50, 32-083 BALICE, POLAND
TEL: +48-12-630-4700 / FAX: +48-12-630-4701

Mitsubishi Electric Turkey A.Ş Ümraniye Şubesi
Turkey Service Center
ŞERİFALİ MAH. NUTUK SOK. NO.5 34775
ÜMRANIYE, İSTANBUL, TURKEY
TEL: +90-216-526-3990 / FAX: +90-216-526-3995

Czech Republic Service Center
KAFKOVA 1853/3, 702 00 OSTRAVA 2, CZECH REPUBLIC
TEL: +420-59-5691-185 / FAX: +420-59-5691-199

Russia Service Center
213, B.NOVOODMITROVSKAYA STR., 14/2, 127015 MOSCOW, RUSSIA
TEL: +7-495-748-0191 / FAX: +7-495-748-0192

MITSUBISHI ELECTRIC EUROPE B.V. (SCANDINAVIA)
Sweden Service Center
HAMMARBACKEN 14 191 49 SOLLENTUNA, SWEDEN
TEL: +46-8-6251000 / FAX: +46-8-966877

Bulgaria Service Center
4 A.LYAPCHEV BOUL., POB 21, BG-1756 SOFIA, BULGARIA
TEL: +359-2-8176009 / FAX: +359-2-9744061

Ukraine (Kharkov) Service Center
APTEKARSKIY LANE 9-A, OFFICE 3, 61001 KHARKOV, UKRAINE
TEL: +380-57-732-7774 / FAX: +380-57-731-8721

Ukraine (Kiev) Service Center
4-B, M. RASKOVOYI STR., 02660 KIEV, UKRAINE
TEL: +380-44-494-3355 / FAX: +380-44-494-3366

Belarus Service Center
OFFICE 9, NEZAVISIMOSTI PR.177, 220125 MINSK, BELARUS
TEL: +375-17-393-1177 / FAX: +375-17-393-0081

South Africa Service Center
5 ALBATROSS STREET, RHODESFIELD, KEMPTON PARK 1619, GAUTENG, SOUTH AFRICA
TEL: +27-11-394-8512 / FAX: +27-11-394-8513

ASEAN**MITSUBISHI ELECTRIC ASIA PTE. LTD. (ASEAN FA CENTER)**

Singapore Service Center
307 ALEXANDRA ROAD #05-01/02 MITSUBISHI ELECTRIC BUILDING SINGAPORE 159943
TEL: +65-6473-2308 / FAX: +65-6476-7439

Malaysia (KL) Service Center
60, JALAN USJ 10/1B 47620 UEP SUBANG JAYA SELANGOR DARUL EHSAN, MALAYSIA
TEL: +60-3-5631-7605 / FAX: +60-3-5631-7636

Malaysia (Johor Baru) Service Center
17 & 17A, JALAN IMPIAN EMAS 5/5, TAMAN IMPIAN EMAS, 81300 SKUDAI, JOHOR MALAYSIA.
TEL: +60-7-557-8218 / FAX: +60-7-557-3404

Philippines Service Center
UNIT NO.411, ALABANG CORPORATE CENTER KM 25, WEST SERVICE ROAD
SOUTH SUPERHIGHWAY, ALABANG MUNTINLUPA METRO MANILA, PHILIPPINES 1771
TEL: +63-2-807-2416 / FAX: +63-2-807-2417

VIETNAM**MITSUBISHI ELECTRIC VIETNAM CO.,LTD**

Vietnam (Ho Chi Minh) Service Center
UNIT 01-04, 10TH FLOOR, VINCOM CENTER 72 LE THANH TON STREET, DISTRICT 1,
HO CHI MINH CITY, VIETNAM
TEL: +84-8-3910 5945 / FAX: +84-8-3910 5946

Vietnam (Hanoi) Service Satellite
SUITE 9-05, 9TH FLOOR, HANOI CENTRAL OFFICE BUILDING, 44B LY THUONG KIET STREET,
HOAN KIEM DISTRICT, HANOI CITY, VIETNAM
TEL: +84-4-3937-8075 / FAX: +84-4-3937-8076

INDONESIA**PT. MITSUBISHI ELECTRIC INDONESIA**

Indonesia Service Center
GEDUNG JAYA 11TH FLOOR, JL. MH. THAMRIN NO.12, JAKARTA PUSAT 10340, INDONESIA
TEL: +62-21-3192-6461 / FAX: +62-21-3192-3942

THAILAND**MITSUBISHI ELECTRIC FACTORY AUTOMATION (THAILAND) CO.,LTD**

Thailand Service Center
12TH FLOOR, SV.CITY BUILDING, OFFICE TOWER 1, NO. 896/19 AND 20 RAMA 3 ROAD,
KWAENG BANGPONGPANG, KHET YANNAWA, BANGKOK 10120, THAILAND
TEL: +66-2-682-6522-31 / FAX: +66-2-682-6020

INDIA**MITSUBISHI ELECTRIC INDIA PVT. LTD.**

India Service Center
2nd FLOOR, TOWER A & B, DLF CYBER GREENS, DLF CYBER CITY,
DLF PHASE-III, GURGAON 122 002, HARYANA, INDIA
TEL: +91-124-4630 300 / FAX: +91-124-4630 399

Ludhiana satellite office
Jamshedpur satellite office

India (Pune) Service Center
EMERALD HOUSE, EL-3, J-BLOCK, MIDC BHOSARI, PUNE – 411 026, MAHARASHTRA, INDIA
TEL: +91-20-2710 2000 / FAX: +91-20-2710 2100

Baroda satellite office
Mumbai satellite office

India (Bangalore) Service Center
PRESTIGE EMERALD, 6TH FLOOR, MUNICIPAL NO. 2,
LAVELLE ROAD, BANGALORE - 560 043, KAMATAKA, INDIA
TEL: +91-80-4020-1600 / FAX: +91-80-4020-1699

Chennai satellite office
Coimbatore satellite office

OCEANIA**MITSUBISHI ELECTRIC AUSTRALIA LTD.**

Australia Service Center
348 VICTORIA ROAD, RYDALMERE, N.S.W. 2116 AUSTRALIA
TEL: +61-2-9684-7269 / FAX: +61-2-9684-7245

CHINA**MITSUBISHI ELECTRIC AUTOMATION (CHINA) LTD. (CHINA FA CENTER)**

China (Shanghai) Service Center
1-3.5-10,18-23/F, NO.1386 HONG QIAO ROAD, CHANG NING QU,
SHANGHAI 200336, CHINA
TEL: +86-21-2322-3030 / FAX: +86-21-2308-3000

China (Ningbo) Service Dealer
China (Wuxi) Service Dealer
China (Jinan) Service Dealer
China (Hangzhou) Service Dealer
China (Wuhan) Service Satellite

China (Beijing) Service Center
9/F, OFFICE TOWER 1, HENDERSON CENTER, 18 JIANGUOMENNEI DAJIE,
DONGCHENG DISTRICT, BEIJING 100005, CHINA
TEL: +86-10-6518-8830 / FAX: +86-10-6518-8030

China (Beijing) Service Dealer

China (Tianjin) Service Center
UNIT 2003, TIANJIN CITY TOWER, NO 35 YOUYI ROAD, HEXI DISTRICT,
TIANJIN 300061, CHINA
TEL: +86-22-2813-1015 / FAX: +86-22-2813-1017

China (Shenyang) Service Satellite
China (Changchun) Service Satellite

China (Chengdu) Service Center
ROOM 407-408, OFFICE TOWER AT SHANGRI-LA CENTER, NO. 9 BINJIANG DONG ROAD,
JINJIANG DISTRICT, CHENGDU, SICHUAN 610021, CHINA
TEL: +86-28-8446-8030 / FAX: +86-28-8446-8630

China (Shenzhen) Service Center
ROOM 2512-2516, 25/F., GREAT CHINA INTERNATIONAL EXCHANGE SQUARE, JINTIAN RD.S.,
FUTIAN DISTRICT, SHENZHEN 518034, CHINA
TEL: +86-755-2399-8272 / FAX: +86-755-8218-4776

China (Xiamen) Service Dealer
China (Dongguan) Service Dealer

KOREA**MITSUBISHI ELECTRIC AUTOMATION KOREA CO., LTD. (KOREA FA CENTER)**

Korea Service Center
1480-6, GAYANG-DONG, GANGSEO-GU, SEOUL 157-200, KOREA
TEL: +82-2-3660-9602 / FAX: +82-2-3664-8668

Korea Taegu Service Satellite
4F KT BUILDING, 1630 SANGYEOK-DONG, BUK-KU, DAEGU 702-835, KOREA
TEL: +82-53-382-7400 / FAX: +82-53-382-7411

TAIWAN**MITSUBISHI ELECTRIC TAIWAN CO., LTD. (TAIWAN FA CENTER)**

Taiwan (Taichung) Service Center (Central Area)
NO.8-1, INDUSTRIAL 16TH RD., TAICHUNG INDUSTRIAL PARK, SITUN DIST.,
TAICHUNG CITY 40768, TAIWAN R.O.C.
TEL: +886-4-2359-0688 / FAX: +886-4-2359-0689

Taiwan (Taipei) Service Center (North Area)
10F, NO.88, SEC.6, CHUNG-SHAN N. RD., SHI LIN DIST., TAIPEI CITY 11155, TAIWAN R.O.C.
TEL: +886-2-2833-5430 / FAX: +886-2-2833-5433

Taiwan (Tainan) Service Center (South Area)
11F-1., NO.30, ZHONGZHENG S. ROAD, YONGKANG DISTRICT, TAINAN CITY 71067, TAIWAN, R.O.C
TEL: +886-6-252-5030 / FAX: +886-6-252-5031

Notice

Every effort has been made to keep up with software and hardware revisions in the contents described in this manual. However, please understand that in some unavoidable cases simultaneous revision is not possible.

Please contact your Mitsubishi Electric dealer with any questions or comments regarding the use of this product.

Duplication Prohibited

This manual may not be reproduced in any form, in part or in whole, without written permission from Mitsubishi Electric Corporation.

COPYRIGHT 2012-2014 MITSUBISHI ELECTRIC CORPORATION
ALL RIGHTS RESERVED

MITSUBISHI CNC



MODEL	E70 Series
MODEL CODE	100-334
Manual No.	IB-1501151